

Tower

Achieves
another Sensation



Develops NEW Diaphragm

IT has long been recognized that the Tower Reproducing Unit gives the most perfect tone quality that science has developed. This already dependable unit is now endowed with new super-performing and super-efficiency qualities establishing a new peak in radio reproduction.

Realizing that true tone color and perfect resonance could never be obtained with the type of diaphragm now in general use, the Tower Mfg. Corporation developed this distinctively new type—a diaphragm of varying thicknesses, consisting of two different materials, so arranged that the deep bass notes of the organ or drum as well as the high notes of the clarinet or violin are reproduced with a clarity and roundness of tone that is wholly new. Thus, this new diaphragm covers the entire musical register as never before accomplished in the art of radio—an achievement long sought but not until now fully realized.



Patents Pending

Tower Speakers, now better than ever, equipped with the wonderful new diaphragm are continued at the same low prices:

- *Meistersinger \$15.00
- *Meistersinger (Cobnet Type) 15.00
- *Scientific 8.50
- *Little Spiffare 4.95
- *Micro Speaker 3.95
- *Phonograph Attachment 3.95
- *Scientific Headset 2.95

*REG. U. S. PAT. OFF.

On sale by Reliable
Dealers from Coast
to Coast

DR. HERMAN FISHER

Designer of the new Tower Diaphragm, first world-war prize by discovering the tone secrets of the master violin makers. In tone tests in Paris, Fisher's violins scored against Stradivari and Gotoh against instruments. Dr. Fisher retained by the Tower Mfg. Co., now applies to radio his wonderful tone discoveries, exclusively employed in the new Tower Speakers.



TOWER MFG. CORPORATION
BOSTON MASS.

RADIO REVIEW

Combined With

Radio Listeners' Guide and Call Book

WITH this number, we present the new combined RADIO REVIEW and RADIO LISTENERS' GUIDE and CALL BOOK to our readers.

We hope that our friends will be as pleased with this first issue as we ourselves are. We are proud of our new magazine. We have spared no cost or effort and we feel that we have achieved something, in both the appearance and contents of this initial issue, that surpasses in completeness, variety, and usefulness—and attractiveness—all that the two separate old publications had to offer.

A change in the publication plans, as announced in the last issue of RADIO REVIEW, makes this the March number instead of the February number which was originally planned. The next issue will be the June number.

Proud as we are of what we have accomplished in the new RADIO REVIEW we realize also that the new magazine is in its beginning. We look forward to possibilities of further expansion, and are eager to seize on all means to open up further avenues of enjoyment and information for our readers, in all directions that may present themselves.

To help us to do this, and because we desire above all things to keep up the close working relation with our readers which has been built up through our previous efforts—a relation which we value as one of the chief gratifications and sources of encouragement in our work—we should be very glad to hear from our readers at the outset as to how they like the new plan of the combined magazines, how well this number has met their expectations, and what other features they would like to see incorporated, or what present ones further developed, in our and their—new RADIO REVIEW.

RADIO REVIEW, Combined with RADIO LISTENERS' GUIDE AND CALL BOOK VOLUME I, NUMBER 8

MARCH, 1926

Published quarterly by The Conrad Co., Inc., 64 Church Street, New York, N. Y., telephone number Barclay 7220; H. Gernsbach, President; S. Gernsbach, Vice President and Treasurer; R. W. De Mott, Secretary. Price 50c a copy; subscriptions \$1.75 a year in the United States of America, Canada and all countries within the domestic postal zone; elsewhere \$2.00 a year, payable in advance. Subscriptions only acceptable in U. S. currency or stamps. No foreign currency or stamps. Checks and money orders should be drawn to the order of THE CONRAD CO., Inc.

When subscribing to RADIO REVIEW, combined with RADIO LISTENERS GUIDE AND CALL BOOK, send your name and remittance to The Conrad Company, Inc., 64 Church Street, New York, N. Y. Mention that you desire to subscribe to RADIO REVIEW. We also publish and distribute CONRAD PATTERNS, E. I. COMPANY BOOKS, etc. Write clearly.

Entered as second class matter, March 10, 1925, at the Post Office at New York, N. Y., and Long Island City, N. Y., under the Act of March 3, 1879.

Copyrighted 1926 by the Conrad Co., Inc., N. Y.

Printed in the U. S. A.

New England Advertising Representative
T. F. Mearns
Park Square Building, Boston, Mass.

Western Advertising Representatives
S. B. Darmstadter
237 W. Madison St.,
Chicago, Ill.

Pacific Coast Advertising Representatives
A. J. Norris Hill Co.
Hearth Bldg., San Francisco, Calif.

General Advertising Department
53 Park Place
New York City

Radio Review

Combined With

Radio Listeners'

GUIDE and CALL BOOK

Sidney Gernsback, Editor

W. G. Many, Associate Editor

THE CONSRAD COMPANY, Inc., 64 Church Street, New York, N. Y.
PUBLISHERS

RADIO BROADCAST STATIONS OF THE UNITED STATES

Indexed Alphabetically by Call Letters

The following list of stations has been so arranged that it can be readily referred to in finding the location, name, power, wave length, frequency and time of a station, providing the call letters are known. The list also serves another purpose and that is for logging the stations received. On the blank side of the page, alongside of a station which has been received on your set, the date, time and dial settings can be written directly on the page.

Radio Call Letters	BROADCAST STATIONS Location and Name	Power Watts	Wave Length (Meters)	Frequency (Kilocycles)	Time at Station	Date	Time Received	Dial 1	Dial 2	Dial 3
KD	KDKA—Pittsburgh, Pa. (Transmitter is in East Pittsburgh)— Westinghouse Electric and Manufacturing Co.	Var.	309.1	970	Eastern					
	KDLR—Devils Lake, N. D.—Radio Elec. Co. & Wilson Ins. Agency.	5	231	1300	Central					
	KDPM—Cleveland, Ohio.—Westinghouse Elec. & Mfg. Co.	500	250	1200	Eastern					
	KDYL—Salt Lake City, Utah.—Newhouse Hotel	50	246	1220	Pacific					
	KDZB—Bakersfield, Calif.—Frank E. Siefert	100	209.7	1430	Pacific					
KF	KFAB—Lincoln, Nebr.—Nebraska Buick Auto Co.	1000	340.7	880	Central					
	KFAD—Phoenix, Ariz.—Electrical Equipment Co. and McArthur Bros. Mercantile Co.	100	273	1100	Mountain					
	KFAF—San Jose, Calif.—Alfred E. Fowler, Montgomery Hotel	50	217.3	1380	Pacific					
	KFAJ—Boulder, Colo.—University of Colo.	100	261	1150	Mountain					
	KFAU—Boise, Idaho.—Boise High School	750	282.8	1060	Pacific					
	KFBB—Havre, Mont.—F. A. Buttrey Co.	50	275	1090	Mountain					
	KFBC—San Diego, Cal.—W. K. Azbill, 5038 Cliff Place.	10	224	1340	Pacific					
	KFBG—Tacoma, Wash.—First Presbyterian Church	50	250	1200	Pacific					
	KFBK—Sacramento, Calif.—Kimball-Upson Co., 607 K. St. ...	100	248	1210	Pacific					
	KFBL—Everett, Wash.—Leese Bros. 2814 Rucker Ave.	100	224	1340	Pacific					
	KFBS—Trinidad, Colo.—School Dist. No. 1	15	238	1220	Mountain					
	KFBU—Laramie, Wyo.—The Cathedral, Bishop N. S. Thomas.	500	270	1110	Mountain					
	KFCB—Phoenix, Ariz.—Nielsen Radio Supply Co., 311 N. Cen- tral Ave.	100	238	1260	Mountain					
	KFCF—Walla Walla, Wash.—Frank A. Moore, 707 Baker Bldg.	100	256	1170	Pacific					
	KFDD—Boise, Idaho.—St. Michaels Cathedral	50	278	1080	Pacific					

Radio Call Letters	BROADCAST STATIONS Location and Name	Power Watts	Wave Length (Meters)	Frequency (Kilohertz)	Time at Station	Date	Time Received	Dial 1	Dial 2	Dial 3
KFDJ	Corvallis, Oregon.—Oregon Agricultural College	500	282.8	1060	Pacific					
KFDM	Beaumont, Tex.—Magnolia Petroleum Co.	500	315.6	950	Central					
KFDX	Shreveport, La.—1st Baptist Church	100	250	1200	Central					
KFDY	Brookings, S. Dakota.—South Dakota State College of Agricultural & Mechanic Arts.	100	273	1100	Central					
KFDZ	Minneapolis, Minn.—H. O. Iverson, 2510 Thomas Ave. South	10	231	1300	Central					
KFEC	Portland, Oregon.—Meier & Frank Co.	50	248	1210	Pacific					
KFEL	Denver, Colo.—W. L. Winner Radio Shop	50	254	1180	Mountain					
KFEQ	Oak, Nebr.—Scroggin & Co. Bank	500	268	1120	Central					
KFEY	Kellogg, Idaho.—Bunker Hill & Sullivan Mining and Concentrating Co.	10	233	1290	Pacific					
KFFP	Moberly, Mo.—First Baptist Church	50	242	1240	Central					
KFFY	Alexandria, La.—Louisiana College	50	275	1090	Central					
KFGC	Baton Rouge, La.—Louisiana State University	100	268	1120	Central					
KFGH	Stanford University, Calif.—Leland Stanford Junior University	500	270	1110	Pacific					
KFGQ	Boone, Iowa.—Crary Hardware Co.	10	226	1330	Central					
KFHA	Gunnison, Colo.—Western State—College of Colo.	50	252	1190	Mountain					
KFHI	Oskaloosa, Iowa.—Penn. College	10	240	1250	Central					
KFI	Los Angeles, Calif.—Earle C. Anthony, Inc.	3000	468.5	640	Pacific					
KFIF	Portland, Oregon.—Benson Polytechnic Institute	100	243	1210	Pacific					
KFIQ	Yakima, Wash.—First Methodist Church	100	256	1170	Pacific					
KFIZ	Fondulac, Wis.—Daily Commonwealth & Wis. Radio Sales, 22 Forest Ave.	100	273	1100	Central					
KFJB	Marshalltown, Iowa.—Marshall Electric Co.	10	248	1210	Central					
KFJC	Junction City, Kans.—Episcopal Church	10	218.8	1370	Central					
KFJF	Oklahoma, Okla.—National Radio Mfg. Co.	500	261	1150	Central					
KFJJ	Astoria, Ore.—Liberty Theatre (E. E. Marsh)	10	246	1220	Pacific					
KFJM	Grand Forks, N. D.—University of N. D.	100	278	1080	Central					
KFJR	Portland, Ore.—Ashley C. Dixon & Son	50	263	1140	Pacific					
KFJX	Cedar Falls, Ia.—Iowa State Teachers' College	50	258	1160	Central					
KFJY	Fort Dodge, Iowa.—Tunwall Radio Co.	50	246	1220	Central					
KFJZ	Fort Worth, Tex.—Southwestern Baptist Theological Seminary	50	254	1180	Central					
KFKA	Greeley, Colo.—Colorado State Teachers College	50	273	1100	Mountain					
KFKU	Lawrence, Kansas.—University of Kansas	500	275	1090	Central					
KFKX	Hastings, Neb.—Westinghouse Elec. & Mfg. Co.	5000	288.3	1040	Central					
KFKZ	Kirksville, Mo.—F. M. Henry	10	226	1330	Central					
KFLR	Albuquerque, N. Mex.—University of New Mexico	100	254	1180	Mountain					
KFLU	San Benito, Tex.—San Benito Radio Club	10	236	1270	Central					
KFLV	Rockford, Ill.—Swedish Evangelical Mission Church	100	229	1310	Central					
KFLX	Galveston, Tex.—Geo. R. Clough, 1214-40th St.	10	240	1250	Central					
KFLZ	Atlantic, Iowa.—Atlantic Automobile Co.	100	273	1100	Central					
KFMQ	Fayetteville, Ark.—University of Arkansas	750	299.8	1000	Central					
KFMR	Sioux City, Iowa.—Morningside College	100	261	1150	Central					
KFMW	Houghton, Mich.—M. G. Sateren, 127 Blanche St.	50	263	1140	Central					
KFMX	Northfield, Minn.—Carleton College	500	336.9	890	Central					
KFNF	Shenandoah, Iowa.—Henry Field Seed Co.	500	263	1140	Central					
KFOA	Seattle, Wash.—Rhodes Department Store	1000	454.3	660	Pacific					
KFOB	Burlingame, Calif.—Burlingame Chamber of Commerce (Albert Sherman)	50	220	1360	Pacific					
KFOJ	Moberly, Mo.—Moberly High School	10	242.0	1240	Central					
KFON	Long Beach, Calif.—Echophone Radio Shop. (Hal G. Nichols)	500	233	1290	Pacific					
KFOO	Salt Lake City, Utah.—Latter Day Saints University	250	236	1270	Pacific					
KFOR	David City, Neb.—David City Tire & Elec. Co. (Howard A. Shuman)	100	226	1330	Central					

Radio Call Letters	BROADCAST STATIONS Location and Name	Power Watts	Wave Length (Meters)	Frequency (Kilocycles)	Time at Station	Date	Time Received	Dial 1	Dial 2	Dial 3
KFOT	Wichita, Kans.—College Hill Radio Club (College Hill Methodist Church).	50	231	1300	Central					
KFOX	Omaha, Neb.—Technical High School (Board of Education).	100	248	1210	Central					
KFOY	St. Paul, Minn.—Beacon Radio Service (M. G. Goldberg) 711 Dayton Ave.	50	252	1190	Central					
KFPL	Dublin, Tex.—C. C. Baxter, 205 Crafton St.	15	252	1190	Central					
KFPM	Greenville, Tex.—New Furniture Co.	10	242	1240	Central					
KFPR	Los Angeles, Calif.—Los Angeles County Forestry Dept.	500	231	1300	Pacific					
KFPW	Cartersville, Mo.—St. Johns M. E. Church, South.	20	258	1160	Central					
KFPY	Spokane, Wash.—Symons Investment Co.	100	266	1130	Pacific					
KFQA	St. Louis, Mo.—The Principia, 5539 Page Ave.	100	261	1150	Central					
KFQB	Fort Worth, Texas.—Searchlight Publishing Co., 408 Throckmorton St.	150	263	1140	Central					
KFQP	Iowa City, Iowa.—Geo. S. Carson, Jr. 906 E. College St.	10	224	1340	Central					
KFQU	Alma (Holy City) Calif.—W. E. Riker	100	217.3	1380	Pacific					
KFQW	North Bend, Wash.—Carl F. Knierim	50	215.7	1390	Pacific					
KFQZ	Hollywood, Calif.—Taft Products Co., 5653 De Longpre Ave.	50	226	1330	Pacific					
KFRB	Beeville, Tex.—Hall Bros.	250	248	1210	Central					
KFRC	San Francisco, Calif.—City of Paris Dry Goods Co.	50	268	1120	Pacific					
KFRM	Fort Sill, Okla.—Lieut. Jas. P. Boland.	50	242	1240	Central					
KFRU	Columbia, Mo.—Stephens College.	500	499.7	600	Central					
KFRW	Olympia, Wash.—United Churches of Olympia.	50	218.8	1370	Pacific					
KFRY	State College, N. Mex.—New Mexico College of Agriculture and Mechanic Arts	50	266	1130	Mountain					
KFSG	Los Angeles, Calif.—Echo Park Evangelistic Ass'n, 1100 Glendale Blvd.	500	275	1090	Pacific					
KFUJ	Breckenridge, Minn.—Hoppert Plumbing & Heating Co. and F. H. Rettig, 120 North Fifth St.	50	242	1240	Central					
KFUL	Galveston, Tex.—Thos. Groggan & Bros. Music Co., 2126 Market St.	50	258	1160	Central					
KFUM	Colorado Springs, Colo.—W. D. Corley, Cascade Ave.	100	242	1240	Mountain					
KFUO	St. Louis, Mo.—Concordia Seminary	500	545.1	550	Central					
KFUP	Denver Colo.—Fitzsimons General Hospital.	50	234	1280	Mountain					
KFUR	Ogden, Utah.—Peery Building Co., 420-25th St.	50	224	1340	Pacific					
KFUS	Oakland, Calif.—Louis L. Sherman, 529-28th St.	50	256	1170	Pacific					
KFUT	Salt Lake City, Utah.—University of Utah.	100	261	1150	Pacific					
KFUU	Oakland, Calif.—Colburn Radio Laboratories, 3020 Broadway.	50	220	1360	Pacific					
KFUV	Springfield, Mo.—G. Pearson Ward, 236 W. State St.	10	252	1190	Central					
KFVD	San Pedro, Calif.—McWhinnie Elec. Co., 1825 So. Pacific Ave.	50	205.4	1460	Pacific					
KFVE	St. Louis, Mo.—Film Corp. of America, 6800 Delmar Blvd.	500	240	1250	Central					
KFVG	Independence, Kans.—First Meth. Episcopal Church.	10	236	1270	Central					
KFVH	Manhattan, Kans.—Whan Radio Shop, 221 Poyntz St.	15	218.8	1370	Central					
KFVI	Houston, Tex.—Fifty Sixth Cavalry Brigade, Headquarters Troop	10	240	1250	Central					
KFVN	Welcome, Minn.—Carl E. Bagley.	50	227	1320	Central					
KFVR	Denver, Colo. (near)—Eugene Rossi, Moonlight Ranch, Route 6.	50	244	1230	Mountain					
KFVS	Cape Girardeau, Mo.—Cape Girardeau Battery Station, (Oscar C. Hirsch).	50	224	1340	Central					
KFVU	Eureka, Calif.—Standard Publishing Co., 537 G. St.	5	209.7	1430	Pacific					
KFVW	San Diego, Cal.—Airfan Radio Corp., 402 B. St.	500	246	1220	Pacific					



Radio Call Letters	BROADCAST STATIONS Location and Name	Power Watts	Wave Length (Meters)	Frequency (Kilocycles)	Time at Station	Date	Time Received	Dial 1	Dial 2	Dial 3
KF	KFVY—Albuquerque, N. Mex.—Radio Supply Co., 413 West Central Ave.	10	250	1200	Mountain					
	KFWA—Ogden, Utah.—Browning Bros. Co., 2451 Kiesel Ave.	500	261	1150	Pacific					
	KFWB—Hollywood, Calif.—Warner Bros. Pictures (Inc.), 5842 Sunset Blvd.	500	252	1190	Pacific					
	KFWD—Arkadelphia, Ark.—Arkansas Light & Power Co. ...	500	266	1130	Central					
	KFWF—St. Louis, Mo.—St. Louis Truth Center, 4030 Lindell St.	250	214.2	1400	Central					
	KFWH—Chico, Calif.—F. Wellington Morse, Jr., 522 Grand Ave., Oakland, Calif.	100	254	1180	Pacific					
	KFWI—So. San Francisco, Calif.—Radio Entertainments Inc. 205 Wiley B. Allen Bldg., San Francisco, Calif.	500	226	1330	Pacific					
	KFWM—Oakland, Calif.—Oakland Education Society, 1136 Bella Vista Ave.	500	206.8	1430	Pacific					
	KFWO—Avalon, Calif.—Lawrence Mott.	250	211.1	1420	Pacific					
	KFWP—Brownsville, Tex.—Rio Grande Radio Supply House... ..	10	214.2	1400	Central					
	KFWU—Pineville, La.—Louisiana College.	100	238	1260	Central					
	KFWV—Portland, Ore.—Wilbur Jerman, 385 E. 58th St., So.	50	212.6	1410	Pacific					
	KFXB—Big Bear Lake, Calif.—Bertram O. Heller.	500	202.6	1480	Pacific					
	KFXC—Santa Maria, Calif.—Santa Maria Valley R. R. Co.	100	209.7	1430	Pacific					
	KFXD—Logan, Utah.—L. H. Strong (Packard Motor Co.) ..	10	205.4	1460	Mountain					
	KFXE—Waterloo, Iowa.—Electrical Research & Mfg. Co.	10	236	1270	Central					
	KFXF—Colorado Springs, Colo.—Pikes Peak Broadcasting Co. 226 Hagerman Building.	500	250	1200	Mountain					
	KFXH—El Paso, Tex.—Bledsoe Radio Co., 2857 Montana St. ..	50	242	1240	Central					
	KFXJ—Denver, Colo.—Mountain States Radio Distributors, 917-14th St.	10	215.7	1390	Mountain					
	KFXM—Beaumont, Tex.—Neches Electric Co., 259 Crockett St.	10	227	1320	Central					
	KFXY—Flagstaff, Ariz.—Mary M. Costigan (Orpheum Theater)	50	205.4	1460	Mountain					
	KFYF—Oxnard, Calif.—Carl's Radio Den (Newcomb Radio Co.) ..	10	205.4	1460	Pacific					
	KFYJ—Houston, Tex. (Portable)—Houston Chronicle Pub. Co.	10	238.0	1260						
	KFYR—Bismark, N. D.—Hoskins-Meyer Inc., 200 Fourth St. .	10	248	1210	Central					
KG	KGB—Tacoma, Wash.—Tacoma Daily Ledger.	100	250	1200	Pacific					
	KGO—Oakland, Calif.—General Electric Co.	3000	361.2	830	Pacific					
	KGTT—San Francisco, Calif.—Glad Tidings Tabernacle.	50	234	1280	Pacific					
	KGW—Portland, Ore.—Portland Morning Oregonian.	500	491.5	610	Pacific					
	KGY—Lacey, Wash.—St. Martins College.	50	246	1220	Pacific					
KH	KHJ—Los Angeles, Calif.—Times Mirror Co., 100 N. Broadway.	500	405.2	740	Pacific					
	KHQ—Spokane, Wash.—Louis Wasmer.	500	273	1100	Pacific					
KJ	KJBS—San Francisco, Calif.—Julius Brunton & Sons Co., 1380 Bush St.	5	220	1360	Pacific					
	KJR—Seattle Wash.—Northwest Radio Service Co., 611 Terminal Sales Bldg.	1000	384.4	780	Pacific					
KL	KLDS—Independence, Mo.—Reorganized Church of Jesus Christ of Latter Day Saints.	1000	440.9	680	Central					
	KLK—Oakland, Calif.—Warner Bros. Radio Supplies Co., 2301 Telegraph Ave.	250	252	1200	Pacific					
	KLX—Oakland, Calif.—Oakland Tribune.	500	508.2	590	Pacific					
	KLZ—Denver, Colo.—Reynolds Radio Co., 1534 Glenarm Place.	250	266	1130	Mountain					
KM	KMA—Shenandoah, Iowa.—May Seed & Nursery Co.	500	252	1190	Central					
	KMJ—Fresno, Calif.—Fresno Bee.	50	234	1280	Pacific					
	KMO—Tacoma, Wash.—Love Elec. Co., 818 North L St.	100	250	1200	Pacific					
	KMOX—St. Louis, Mo.—Mayfair Hotel.	1000	261	1150	Central					
	KMTR—Los Angeles, Calif.—K. M. Turner Radio Corp. (Oliver S. Garretson), 1517 N. Wilton St.	500	238	1260	Pacific					
KN	KNRC—Los Angeles, Calif.—Clarence B. Juneau, 8083 Santa Monica Blvd.	250	208.2	1440	Pacific					

Radio Call Letters	BROADCAST STATIONS Location and Name	Power Watts	Wave Length (Meters)	Frequency (Kilohertz)	Time at Station	Date	Time Received	Dial 1	Dial 2	Dial 3
KN	KNX—Los Angeles, Calif.—Los Angeles Evening Express, 6116 Hollywood Blvd.	500	336.9	890	Pacific					
KO	KOA—Denver, Colo.—General Electric Co., 1370 Krameria St.	5000	322.4	930	Mountain					
	KOB—State College, N. Mex.—New Mexico College of Agriculture and Mechanic Arts.	1000	348.6	860	Mountain					
	KOCH—Omaha, Neb.—Omaha Central High School.	250	258	1160	Central					
	KOCW—Chickasha, Okla.—Oklahoma College for Women.	200	252	1190	Central					
	KOIL—Council Bluffs, Iowa.—Monarch Mfg. Co.	500	278	1080	Central					
KP	KPO—San Francisco, Calif.—Hale Bros.	1000	428.3	700	Pacific					
	KPPC—Pasadena, Calif.—Pasadena Presbyterian Church.	50	229	1310	Pacific					
	KPRC—Houston, Tex.—Post Dispatch.	500	296.9	1010	Central					
	KPSN—Pasadena, Calif.—Pasadena Star-News.	1000	315.6	950	Pacific					
KQ	KQP—Portland, Oregon.—H. B. Read, 441 Sixth St.	500	212.6	1410	Pacific					
	KQV—Pittsburgh, Pa.—Doubleday-Hill Electric Co., 719 Liberty Ave.	500	275	1090	Eastern					
	KQW—San Jose, Calif.—First Baptist Church, Montevina Ave.	500	231	1300	Pacific					
KR	KRE—Berkeley, Calif.—Berkeley Daily Gazette.	100	256	1170	Pacific					
KS	KSAC—Manhattan, Kas.—Kansas State Agricultural College.	500	340.7	880	Central					
	KSD—St. Louis, Mo.—Post Dispatch.	500	545.1	550	Central					
	KSL—Salt Lake City, Utah.—Radio Service Corp. of Utah, 505 Templeton Building.	1000	299.8	1000	Pacific					
	KSO—Clarinda, Iowa.—A. A. Berry Seed Co.	500	242	1240	Central					
KT	KTAB—Oakland, Calif.—Tenth Ave. Baptist Church.	1000	240	1250	Pacific					
	KTBI—Los Angeles, Calif.—Bible Institute of Los Angeles.	750	293.9	1020	Pacific					
	KTBR—Portland, Oregon.—Brown's Radio Shop, 172-10th St.	50	263	1140	Pacific					
	KTCL—Seattle, Wash.—American Radio Telephone Co.	1000	305.9	980	Pacific					
	KTHS—Hot Springs, Ark.—New Arlington Hotel Co.	500	374.8	800	Central					
	KTNT—Muscatine, Iowa.—Norman Baker.	500	256	1170	Central					
	KTW—Seattle, Wash.—First Presbyterian Church.	1000	454.3	660	Pacific					
KU	KUO—San Francisco, Cal.—Examiner Printing Co.	150	250	1200	Pacific					
	KUOM—Missoula, Mont.—University of Montana.	250	244	1230	Mountain					
	KUSD—Vermillion, S. D.—University of S. D.	100	278	1080	Central					
	KUT—Austin, Tex.—University of Texas.	500	231	1300	Central					
KV	KVOO—Bristow, Oklahoma—Voice of Oklahoma.	500	374.8	800	Central					
KW	KWCR—Cedar Rapids, Iowa.—H. F. Paar, 1444 Second Avenue, E.	500	278	1080	Central					
	KWG—Stockton, Calif.—Portable Wireless Telephone Co., 530 East Market St.	50	248	1210	Pacific					
	KWKC—Kansas City, Mo.—Wilson Duncan Studios, Werby Building.	100	236	1270	Central					
	KWKH—Kennonwood, La.—W. G. Patterson, 406 Market St.	500	261	1150	Central					
	KWSC—Pullman, Wash.—State College of Washington.	500	348.6	860	Pacific					
	KWUC—Le Mars, Iowa.—Western Union College.	50	252	1190	Central					
	KWWG—Brownsville, Tex.—City of Brownsville, Board of City Development.	500	278	1080	Central					
KY	KYW—Chicago, Illinois—Westinghouse Electric & Manufacturing Co.	2000	535.4	560	Central					
KZ	KZM—Oakland, Calif.—Preston D. Allen, 13th & Harrison Sts.	100	240	1250	Pacific					
NA	NAA—Arlington, Virginia—United States Navy.	1000	434.5	690	Eastern					
WA	WAAB—New Orleans, La.—Valdemar Jensen, 137 So. Saint Patrick St.	100	268	1120	Central					
	WAAD—Cincinnati, Ohio.—Ohio Mechanics Institute.	25	258	1160	Central					
	WAAF—Chicago, Ill.—Chicago Daily Drivers Journal.	200	278	1080	Central					

Radio Call Letters	BROADCAST STATIONS Location and Name	Power Watts	Wave Length (Meters)	Frequency (Kilocycles)	Time at Station	Date	Time Received	Dist 1	Dist 2	Dist 3
WA	WAAM—Newark, N. J.—L. R. Nelson Co., 1 Bond St. (This station is temporarily broadcasting from New York, N. Y. under call WBPI)	500	263	1140	Eastern					
	WAAW—Omaha, Neb.—Omaha Grain Exchange	500	278	1080	Central					
	WABB—Harrisburg, Pa.—Harrisburg Sporting Goods Co.	10	266	1130	Eastern					
	WABC—Asheville, N. C.—Asheville Battery Co., 19 Haywood St.	20	254	1180	Central					
	WABI—Bangor, Me.—First Universalist Church.	100	240	1250	Eastern					
	WABO—Rochester, N. Y.—Lake Ave. Baptist Church (Hickson Electric Co.)	100	278	1080	Eastern					
	WABQ—Haverford, Pa.—Haverford College Radio Club.	100	261	1150	Eastern					
	WABR—Toledo, Ohio.—Scott High School.	50	263	1140	Central					
	WABW—Wooster, Ohio.—College of Wooster.	50	206.8	1450	Eastern					
	WABX—Mount Clemens, Mich. (near)—Henry B. Joy, 1830 Penobscot Building, Detroit, Mich.	500	246	1220	Central					
	WABY—Philadelphia, Pa.—John Magaldi, Jr., 815 Kimball St.	50	242	1240	Eastern					
	WABZ—New Orleans, La.—Coliseum Mace Baptist Church. . .	50	275	1090	Central					
	WADC—Akron, Ohio.—Allen Theater (Allen T. Simmons). . .	500	258	1160	Eastern					
	WAFD—Port Huron, Mich.—Albert B. Parfet Co., 1432 Military Road.	500	275	1090	Central					
	WAGM—Royal Oak, Mich.—Robert L. Miller.	50	258.6	1160	Central					
	WAHG—Richmond Hill, N. Y.—A. H. Grebe & Co.	500	315.6	950	Eastern					
	WAIT—Taunton, Mass.—A. H. Waite & Co., 32 Weir St.	10	229	1310	Eastern					
	WAIU—Columbus, Ohio.—American Insurance Union.	500	293.9	1020	Central					
	WAMD—Minneapolis, Minn.—Hubbard & Co. (Twin City Barber College, Marigold Gardens).	500	244	1230	Central					
	WAPI—Auburn, Ala.—Alabama Polytechnic Institute.	500	248	1210	Central					
	WARC—Medford Hillside, Mass.—American Radio & Research Corp.	100	261	1150	Eastern					
WB	WBAA—West Lafayette, Ind.—Purdue University.	250	273	1100	Central					
	WBAK—Harrisburg, Pa.—Pennsylvania State Police.	500	275	1090	Eastern					
	WBAL—Baltimore, Md.—Consolidated Gas, Electric Light & Power Co.	1000	374.8	1800	Eastern					
	WBAO—Decatur, Ill.—James Millikin University.	100	270	1110	Central					
	WBAP—Fort Worth, Texas.—Star Telegram	1500	475.9	630	Central					
	WBAX—Wilkes-Barre, Pa.—John H. Stenger, Jr. 66 Gildersleeve St.	100	256	1170	Eastern					
	WBBL—Richmond, Va.—Grace Covenant Presbyterian Church.	100	229	1510	Eastern					
	WBBM—Chicago, Ill.—Atlas Investment Co., 1554 Howard St.	1500	226	1330	Central					
	WBBP—Petoskey, Mich.—Petoskey High School.	200	238	1260	Central					
	WBBR—Rossville, N. Y.—Peoples Pulpit Ass'n., 124 Columbia Heights, Brooklyn.	500	273	1100	Eastern					
	WBBS—New Orleans, La.—First Baptist Church.	50	252	1190	Central					
	WBBW—Norfolk, Va.—Ruffner Junior High School.	50	222	1350	Eastern					
	WBBY—Charleston, S. C.—Washington Light Infantry.	10	268	1120	Eastern					
	WBCN—Chicago, Ill.—Foster & McDonnell, 728 W. 65th St. . .	500	266	1130	Central					
	WBBZ—Chicago, Ill. (Portable)—C. L. Carrell, 1506 North American Building.	50	215.7	1390						
	WBDC—Grand Rapids, Mich.—Baxter Laundry Co.	50	256	1170	Central					
	WBES—Takoma Park, Md.—Bliss Electrical School.	100	222	1350	Eastern					
	WBOQ—Richmond Hill, N. Y.—A. H. Grebe & Co., 70 Van Wyck Boulevard.	100	236	1270	Eastern					
	WBPI—New York, N. Y.—Warner Bros. Theatre. (WAAM at Newark, N. J. is temporarily broadcasting from New York, N. Y. under call WBPI)	500	263	1140	Eastern					
	WBRC—Birmingham, Ala.—Bell Radio Corporation, 1913 Fifth Ave. N.	10	248	1210	Central					
	WBRE—Wilkes Barre, Pa.—Baltimore Radio Exchange, 17 W. Northampton St.	100	231	1300	Eastern					

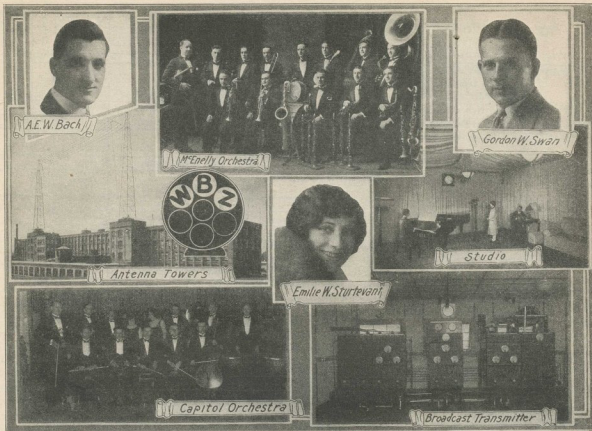

Radio Call Letters	BROADCAST STATIONS Location and Name	Power Watts	Wave Length (Meters)	Frequency (Kilocycles)	Time of Station	Date	Time Received	Dial 1	Dial 2	Dial 3
WB	WBT—Charlotte, N. C.—Charlotte Chamber of Commerce. (C. Coddington).	250	275	1090	Eastern					
	WBZ—Springfield, Mass.—Westinghouse Elec. & Mfg. Co.	2000	331.1	900	Eastern					
	WBZA—Boston, Mass.—Westinghouse Elec. & Mfg. Co.	250	242	1240	Eastern					
WC	WCAC—Mansfield, Conn.—Connecticut Agricultural College.	500	275	1090	Eastern					
	WCAD—Canton, N. Y.—St. Lawrence University.	250	263	1140	Eastern					
	WCAE—Pittsburgh, Pa.—Kaufmann & Baer Co., 6th and Smithfield Streets.	500	461.3	650	Eastern					
	WCAH—Columbus, Ohio.—Entrekin Elec. Co., 321 W. 10th Ave.	500	266	1130	Central					
	WCAJ—University Pl., Neb.—Nebraska Wesleyan University.	500	254	1180	Central					
	WCAL—Northfield, Minn.—St. Olaf College.	500	336.9	890	Central					
	WCAO—Baltimore, Md.—Albert A. and A. Stanley Brager.	100	275	1090	Eastern					
	WCAP—Washington, D. C.—Chesapeake & Potomac Telephone Co.	500	468.5	640	Eastern					
	WCAR—San Antonio, Tex.—Southern Radio Corp. of Texas, 324 North Navarro St.	500	263	1140	Central					
	WCAT—Rapid City, S. Dak.—South Dakota State School of Mines.	50	240	1250	Mountain					
	WCAU—Philadelphia, Pa.—Universal Broadcasting Co. (Durham & Co.)	500	278	1080	Eastern					
	WCAX—Burlington, Vt.—University of Vermont.	100	250	1200	Eastern					
	WCBA—Allentown, Pa.—Charles W. Heimbach, 1015 Allen St.	15	254	1180	Eastern					
	WCBC—Ann Arbor, Mich.—University of Michigan.	200	229	1310	Central					
	WCBD—Zion, Ill.—Wilbur G. Voliva.	5000	344.6	870	Central					
	WCBE—New Orleans, La.—Uhalt Bros. Radio Co., 200 Camp St.	5	263	1140	Central					
	WCBG—Pascagoula, Miss. (Portable)—Howard S. Williams.	10	268	1120						
	WCBH—Oxford, Miss. (near)—University of Mississippi.	50	242	1240	Central					
	WCBM—Baltimore, Md.—Hotel Chateau (Chas. Schwarz).	50	229	1310	Eastern					
	WCBQ—Nashville, Tenn.—First Baptist Church.	100	236	1270	Central					
	WCBR—Providence, R. I. (Portable)—Chas. H. Messter, 42 Doyle Ave.	30	205.4	1460						
	WCCO—St. Paul—Minneapolis, Minn.—Washburn-Crosby Co.	5000	416.4	720	Central					
	WCEE—Elgin, Ill. (near)—Liberty Weekly.	1000	275	1090	Central					
	WCLO—Camp Lake, Wis.—C. E. Whitmore.	50	231	1300	Central					
	WCLS—Joliet, Ill.—Harold M. Couch.	150	214.2	1400	Central					
	WCSH—Portland, Me.—Congress Square Hotel Co.	500	256	1170	Eastern					
	WCSSO—Springfield, Ohio.—Wittenberg College.	100	248	1210	Central					
	WCUW—Worcester, Mass.—Clark University.	250	238	1260	Eastern					
	WCWS—Providence, R. I. (Portable)—Chas. W. Selen, 69 Exchange St.	100	209.7	1430						
	WCX—Pontiac, Mich.—Detroit Free Press.	2500	516.9	580	Central					
WD	WDAD—Nashville, Tenn.—Dad's Auto Accessories Inc., 160 Eighth Ave. North.	150	226	1330	Central					
	WDAE—Tampa, Fla.—Daily Times.	250	273	1100	Eastern					
	WDAF—Kansas City, Mo.—Kansas City Star.	500	365.6	820	Central					
	WDAG—Amarillo, Texas—J. Laurance Martin.	100	263	1140	Central					
	WDAY—Fargo, N. D.—Radio Equipment Corp.	50	261	1150	Central					
	WDBC—Lancaster, Pa.—Kirk, Johnson & Co., 16 W. King St.	50	258	1160	Eastern					
	WDBE—Atlanta, Ga.—Gilhan-Schoen Elec. Co., 35 Cone St.	100	270	1110	Central					
	WDBJ—Roanoke, Va.—Richardson-Wayland Electric Corp., 106 Church St. S. W.	50	229	1310	Eastern					
	WDBK—Cleveland, Ohio.—M. F. Broz Furniture, Hdwe. and Radio Store, 13918 Union Ave.	100	227	1320	Eastern					
	WDBO—Winter Park, Fla.—Rollins College.	500	240	1250	Eastern					
	WDBR—Boston, Mass.—Tremont Temple Baptist Church.	100	261	1150	Eastern					
	WDBZ—Kingston, N. Y.—Boy Scouts of America (Ulster County Council).	10	233	1290	Eastern					

Radio Call Letters	BROADCAST STATIONS Location and Name	Powers Watts	Wave Length (Meters)	Frequency (Kilocycles)	Time at Station	Date	Time Received	Dial 1	Dial 2	Dial 3
WD	WDCH—Hanover, N. H.—Dartmouth College	100	256	1170	Eastern					
	WDDO—Chattanooga, Tenn.—Chattanooga Radio Co., 540 McCallie Ave.	500	256	1170	Central					
	WDRG—New Haven, Conn.—Doolittle Radio Corporation, 115 Crown St.	100	268	1120	Eastern					
	WDWF—Cranston, R. I.—Dutee W. Flint.	500	440.9	680	Eastern					
	WDZ—Tuscola, Ill.—Jas. L. Bush.	10-100	278	1080	Central					
WE	WEAF—New York, N. Y.—American Telephone & Telg. Co., 195 Broadway	5000	491.5	610	Eastern					
	WEAH—Wichita, Kans.—Hotel Lassen (Rigby Gray Hotel Co.)	50	268	1120	Central					
	WEAI—Ithaca, N. Y.—Cornell University.	500	254	1180	Eastern					
	WEAM—North Plainfield, N. J.—Borough of North Plainfield (W. G. Buttfield)	250	261	1150	Eastern					
	WEAN—Providence, R. I.—Shepard Co.	500	270	1110	Eastern					
	WEAO—Columbus, Ohio.—Ohio State University.	500	293.9	1020	Central					
	WEAR—Cleveland, Ohio.—Goodyear Tire & Rubber Co.	750	389.4	770	Eastern					
	WEAU—Sioux City, Iowa—Davidson Bros. Co.	100	275	1090	Central					
	WEAY—Houston, Texas—Iris Theatre (Will Horowitz, Jr.) . .	500	270	1110	Central					
	WEBC—Superior, Wis.—Walter C. Bridges, 1225 Tower St. . .	100	242	1240	Central					
	WEBD—Anderson, Ind.—Electrical Equipment & Service Co.	15	246	1220	Central					
	WEBE—Cambridge, Ohio.—Roy W. Waller, 319 Wall Ave. . .	10	234	1280	Eastern					
	WEBH—Chicago, Ill.—Edgewater Beach Hotel Co., 5349 Sher- idan Road.	1500	370.2	810	Central					
	WEBJ—New York, N. Y.—Third Ave. Railway Co., 2396 Third Ave.	500	273	1100	Eastern					
	WEBK—Grand Rapids, Mich.—Grand Rapids Radio Co., 211 Diamond Ave. S. E.	100	242	1240	Central					
	WEBL—United States (Portable)—Radio Corp. of America. .	100	226	1330						
	WEBM—United States (Portable)—Radio Corp. of America. .	100	226	1330						
	WEBQ—Harrisburg, Ill.—Jos. R. Tate, 700 W. Robinson St. .	10	226	1330	Central					
	WEBR—Buffalo, N. Y.—H. H. Howell, 54 Niagara St.	50	244	1230	Eastern					
	WEBT—Dayton, Ohio.—Dayton Cooperative Industrial High School.	5	256	1170	Central					
	WEBW—Beloit, Wis.—Beloit College.	500	268	1120	Central					
	WEBZ—Savannah, Ga.—Savannah Radio Corp., 11 E. York St.	5	263	1140	Eastern					
	WEEL—Boston, Mass.—Edison Electric Illuminating Co.	500	475.9	630	Eastern					
	WEHS—Evanston, Ill.—Robert E. Hughes.	10	202.6	1480	Central					
	WEMC—Berrien Springs, Mich.—Emmanuel Missionary College.	500	285.5	1050	Central					
	WENR—Chicago, Ill.—All American Radio Corporation, 4201 Belmont Avenue.	1000	266	1130	Central					
	WEW—St. Louis, Mo.—St. Louis University.	100	248	1210	Central					
	WFAA—Dallas, Tex.—Dallas News and Dallas Journal	500	475.9	630	Central					
WF	WFAM—St. Cloud, Minn.—Times Publishing Co.	10	273	1100	Central					
	WFAV—Lincoln, Neb.—University of Nebraska, Dept. of Electrical Engineering.	500	275	1090	Central					
	WFBC—Knoxville, Tenn.—First Baptist Church.	50	250	1200	Central					
	WFBD—Philadelphia, Pa.—Gethsemane Baptist Church.	5	234	1280	Eastern					
	WFBE—Seymour, Ind.—Van DeWalle Music & Radio Co., 208 West Second St.	10	226	1330	Central					
	WFBG—Altoona, Pa.—William F. Gable Co.	100	278	1080	Eastern					
	WFBH—New York, N. Y.—Concourse Radio Corporation, Hotel Majestic.	500	273	1100	Eastern					
	WFBJ—Camden, N. J.—Galvin Radio Supply Co., 521 Market St.	250	236	1270	Eastern					
	WFBK—Collegeville, Minn.—St. John's University.	100	236	1270	Central					
	WFBM—Syracuse, N. Y.—Onondaga Hotel Co.	100	252	1190	Eastern					
	WFBN—Indianapolis, Ind.—Merchants Heat & Light Co.	250	268	1130	Central					

Radio Call Letters	BROADCAST STATIONS Location and Name	Power Watts	Wave Length (Meters)	Frequency (Kilocycles)	Time at Station	Date	Time Received	Dial 1	Dial 2	Dial 3
WF	WFBR—Baltimore, Md.—Fifth Infantry National Guard. Fifth Regt. Armory.	100	254	1180	Eastern					
	WFBE—Galesburg, Ill.—Knox College.	20	254	1180	Central					
	WFDF—Flint, Mich.—Frank D. Fallain, Police Bldg.	100	234	1280	Central					
	WFI—Philadelphia, Pa.—Strawbridge & Clothier.	500	394.5	760	Eastern					
	WFKB—Chicago, Ill.—Francis K. Bridgman, 4536 Woodlawn Ave.	500	217.3	1380	Central					
	WFRJ—Brooklyn, N. Y.—Robt. M. Lacey and Jas. A. Bergner (Flatbush Radio Lab.), 1421 East 10th St.	100	205.4	1460	Eastern					
WG	WGAL—Lancaster, Pa.—Lancaster Elec. Supply & Construction Co.	10	248	1210	Eastern					
	WGBB—Freeport, N. Y.—Harry H. Carman.	100	244	1230	Eastern					
	WGBC—Memphis, Tenn.—First Baptist Church.	10	278	1080	Central					
	WGBF—Evansville, Ind.—Finke Furniture Co., 307 South Seventh St.	100	236	1270	Central					
	WGBI—Scranton, Pa.—Frank S. Megargee, 608 Linden St. . .	10	240	1250	Eastern					
	WGBK—Johnstown, Pa.—Lawrence W. Campbell (Fountaine Chateau).	5	248	1210	Eastern					
	WGBM—Providence, R. I.—Theo. N. Saaty, 92 Dover St.	30	234	1280	Eastern					
	WGBQ—Menominee, Wis.—Stout Institute.	100	234	1280	Central					
	WGBR—Marshfield, Wis.—Geo. S. Ives, 731 West Fifth St.	10	229	1310	Central					
	WGBS—New York, N. Y.—Gimbel Bros.	500	315.6	950	Eastern					
	WGBT—Greenville, S. C.—Furman University.	15	236	1270	Eastern					
	WGBU—Fulford-by-the-Sea, Fla.—Florida Cities Finance Co. .	500	278	1080	Eastern					
	WGBX—Orono, Me.—University of Maine.	100	252	1190	Eastern					
	WGCP—New York, N. Y.—Grand Central Palace. (Transmitter is in Newark, N. J. Owned by D. W. May (Inc.), 325 Central Avenue, Newark, N. J.)	500	252	1190	Eastern					
	WGES—Oak Park, Ill.—Oakleaves Broadcasting Station (Coyne Electrical School).	500	250	1200	Central					
	WGHB—Clearwater, Fla.—The Geo. H. Bowles Developments.	500	266	1130	Eastern					
	WGHP—Detroit, Mich.—Geo. H. Phelps, 110 Rowena St.	1500	270	1110	Central					
	WGMU—Richmond Hill, N. Y. (portable)—A. H. Grebe & Co.	100	236	1270	Eastern					
	WGN—Chicago, Ill.—The Tribune (Drake Hotel).	1000	302.8	990	Central					
	WGR—Buffalo, N. Y.—Federal Radio Corp. (Federal Telephone Mfg. Corp.)	750	319	940	Eastern					
	WGST—Atlanta, Ga.—Georgia School of Technology	500	270	1110	Central					
	WGY—Schenectady, N. Y.—General Electric Co.	5000	379.5	790	Eastern					
WH	WHA—Madison, Wis.—University of Wisconsin	750	535.4	560	Central					
	WHAD—Milwaukee, Wis.—Marquette University and Milwaukee Journal	500	275	1090	Central					
	WHAG—Cincinnati, Ohio.—University of Cincinnati	100	233	1290	Central					
	WHAM—Rochester, N. Y.—University of Rochester (Eastman School of Music)	100	278	1080	Eastern					
	WHAP—New York, N. Y.—W. H. Taylor Finance Corp., 426 West 31st Street	500	240	1250	Eastern					
	WHAR—Atlantic City, N. J.—Seaside Hotel	500	275	1090	Eastern					
	WHAS—Louisville, Ky.—Courier-Journal and Louisville Times	500	399.8	750	Central					
	WHAT—Minneapolis, Minn.—Geo. W. Young, 2219 North Bryant Ave.	500	263	1140	Central					
	WHAV—Wilmington, Del.—Wilmington Elec. Specialty Co. 405 Delaware Ave.	100	266	1130	Eastern					
	WHAZ—Troy, N. Y.—Rensselaer Polytechnic Institute	1000	379.5	790	Eastern					
	WHB—Kansas City, Mo.—Sweeney School Co., Sweeney Bldg.	500	365.6	820	Central					
	WHBA—Oil City, Pa.—Shaffer Music House	10	250	1200	Eastern					
	WHBC—Canton, Ohio.—Rev. E. P. Graham, 627 McKinley Avenue, N. W.	10	254	1180	Eastern					
	WHBD—Bellefontaine, Ohio.—Chas. W. Howard	20	222	1350	Central					



G.E. Zimmermann

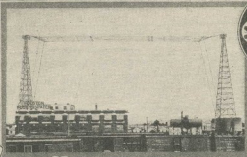

Antenna System



Studio



Control Room



A.P. Daniel



Frank Tilton



W.G.Y. Players



Martin Price



Orchestra



Ten Eyck Clay



Kolen Hager



Main Studio



Radio Four

RADIO BROADCAST STATIONS OF THE UNITED STATES BY CALL LETTERS

Radio Call Letters	BROADCAST STATIONS Location and Name	Power Watts	Wave Length (Meters)	Frequency (Kilohertz)	Time at Station	Date Received	Dial 1	Dial 2	Dial 3
WH	WHBF—Rock Island, Ill.—Beardsley Specialty Co., 217 Eighteenth Street	100	222	1350	Central				
	WHBG—Harrisburg, Pa.—John S. Skane, 1810 North Fourth St.	20	231	1300	Eastern				
	WHBH—Culver, Ind.—Culver Military Academy	100	222	1350	Central				
	WHBJ—Fort Wayne, Ind.—Lauer Auto Co., 2315 South Calhoun Street	50	234	1280	Central				
	WHBK—Elisworth, Me.—Franklin Street Garage	10	231	1300	Eastern				
	WHBL—Logansport, Ind.—Jas. H. Siusser, 1214 A Avenue	50	215.7	1390	Central				
	WHBM—Chicago, Ill. (Portable)—C. L. Carrell, 1536 S. State St.	20	233	1290	Central				
	WHBN—St. Petersburg, Fla.—First Avenue Methodist Church	10	238	1260	Eastern				
	WHBP—Johnstown, Pa.—Johnstown Automobile Co.	100	256	1170	Eastern				
	WHBQ—Memphis, Tenn.—Men's Fellowship Class of St. Johns Methodist Episcopal Church South	50	233	1290	Central				
	WHBR—Cincinnati, Ohio.—Scientific Electric & Mfg. Co., 1745 Reading Road	20	215.7	1390	Central				
	WHBU—Anderson, Ind.—Rivera Theatre & Bing's Clothing, 1002 Meridian St.	10	218.8	1370	Central				
	WHBW—Philadelphia, Pa.—D. R. Kienzie, 4916 Chestnut St.	100	215.7	1390	Eastern				
	WHBY—West De Pere, Wis.—St. Norbert's College	50	250	1200	Central				
	WHDI—Minneapolis, Minn.—Wm. Hood Dunwoody Industrial Institute	500	278	1080	Central				
	WHEC—Rochester, N. Y.—Hickson Electric Co., 36 South Ave.	100	258	1160	Eastern				
	WHK—Cleveland, Ohio.—Radio Air Service Corp., 1031 Winton Hotel	250	273	1100	Eastern				
	WHN—New York, N. Y.—Geo. Schubel, 1540 Broadway	500	361.2	830	Eastern				
	WHO—Des Moines, Iowa.—Bankers Life Co.	5000	526	570	Central				
	WHT—Chicago, Ill.—(Transmitter is in Deerfield, Ill.)—Radio-phone Broadcasting Corp., 410 N. Michigan Blvd., Chicago, Ill.	2500	238	1260	Central				
WI	WIAD—Philadelphia, Pa.—Howard R. Miller, 6318 N. Park Ave.	100	250	1200	Eastern				
	WIAS—Burlington, Iowa.—Home Electric Co.	100	254	1180	Central				
	WIBA—Madison, Wis.—Capital Times Studio, 237 West Gilman Street	100	236	1270	Central				
	WIBC—St. Petersburg, Fla.—L. M. Tate Post No. 39, Veterans of Foreign Wars	100	222	1350	Eastern				
	WIBG—Elkins Park, Pa.—St. Paul's Protestant Epis. Church	50	222	1350	Eastern				
	WIBH—New Bedford, Mass.—Elite Radio Stores, 55 Hillman St.	5	209.7	1430	Eastern				
	WIBI—Flushing, N. Y.—Frederick B. Zittel, Jr. 49 Boerum Ave.	50	218.8	1370	Eastern				
	WIBJ—Chicago, Ill. (Portable)—C. L. Carrell, 36 So. State St.	50	215.7	1390					
	WIBK—Toledo, Ohio.—University of the City of Toledo	100	205.4	1460	Central				
	WIBM—Chicago, Ill. (Portable)—Billy Maine, 36 West Randolph Street	10	215.7	1390					
	WIBO—Chicago, Ill.—Nelson Bros. (Russo & Fiorito Orchestral Exchange), 6310 Broadway	1000	226	1330	Central				
	WIBR—Weirton, W. Va.—Thurman A. Owings	50	246	1220	Eastern				
	WIBS—Elizabeth, N. J. (Portable)—New Jersey National Guard, Fifty-seventh Infantry Brigade	10	202.6	1480					
	WIBU—Poynette, Wis.—The Electric Farm	20	222	1350	Central				
	WIBV—Henderson, N. C.—Jewell Radio Co.	25	263	1140	Eastern				
	WIBW—Logansport, Ind.—L. L. Dill, Barnes Building	100	220	1360	Central				
	WIBX—Utica, N. Y.—Grid-Leak (Inc.), 236 Genesee St.	150	205.4	1460	Eastern				
	WIBZ—Montgomery, Ala.—Powell Electric Co., 811 Adams Ave.	10	231	1300	Central				
	WIL—St. Louis, Mo.—St. Louis Star and Benson Radio Co.	250	273	1100	Central				
	WIP—Philadelphia, Pa.—Gimbel Bros.	500	508.2	590	Eastern				
WJ	WJAD—Waco, Tex.—Frank P. Jackson	500	352.7	850	Central				
	WJAG—Norfolk, Nehr.—Daily News	200	270	1110	Central				
	WJAK—Greentown, Ind.—Rev. C. L. White	50	254	1180	Central				
	WJAM—Cedar Rapids, Ia.—D. M. Perham, 322 Third Ave. W.	100	268	1120	Central				

Radio Call Letters	BROADCAST STATIONS Location and Name	Power Watts	Wave Length (Meters)	Frequency (Kilohertz)	Time at Station	Date	Time Received	Dial 1	Dial 2	Dial 3
WJ	WJAR—Providence, R. I.—The Outlet Co.	500	305.9	980	Eastern					
	WJAS—Pittsburgh, Pa.—Pittsburgh Radio Supply House ...	500	275	1090	Eastern					
	WJAX—Jacksonville, Fla.—City of Jacksonville	1000	336.9	890	Eastern					
	WJAZ—Chicago, Ill.—(Transmitter is in Mount Prospect, Ill.) Zenith Radio Corporation, 312 South Michigan Ave. ..	1500	322.4	930	Central					
	WJBA—Joliet, Ill.—D. H. Lentz, Jr., 301 Whitley Ave.	50	206.8	1450	Central					
	WJBB—St. Petersburg, Fla.—L. W. McClung, 1922 Central Ave.	10	254	1180	Eastern					
	WJBC—LaSalle, Ill.—Hummer Furniture Co., 2nd and Joliet Sts	100	234	1280	Central					
	WJBG—Charlotte, N. C.—Interstate Radio (Inc.), 7 West Fourth Street	10	224	1340	Eastern					
	WJBI—Red Bank, N. J.—Robt. S. Johnson, 63 Broad St.	250	218.8	1370	Eastern					
	WJBK—Ypsilanti, Mich.—Ernest F. Goodwin, 803 Congress St.	10	233	1290	Central					
	WJBL—Decatur, Ill.—Wm. Gushard Dry Goods Co., 301 N. Water Street	500	270	1110	Central					
	WJBN—Sycamore, Ill.—St. Johns Evangelical Lutheran Church	10	256	1170	Central					
	WJBP—Buffalo, N. Y.—Seneca Vocational School	50	218.8	1370	Eastern					
	WJBQ—Lewisburg, Pa.—Bucknell University	100	211.1	1420	Eastern					
	WJD—Granville, Ohio.—Denison University	10	217.3	1380	Central					
	WJJD—Mooseheart, Ill.—Supreme Lodge, Loyal Order of Moose	500	370.2	810	Central					
	WJR—Detroit, Mich. (Transmitter is in Pontiac, Mich.)—Jewett Radio & Phonograph Co.	2500	516.9	580	Central					
	WJY—New York, N. Y.—Radio Corp. of America	1000	405.2	740	Eastern					
	WJZ—New York, N. Y.—Radio Corp. of America	1000	454.3	660	Eastern					
WK	WKAD—East Providence, R. I.—Chas. Looff (Crescent Park)	20	240	1250	Eastern					
	WKAF—Milwaukee, Wis.—WKAF Broadcasting Co., 130 2nd St.	500	261	1150	Central					
	WKAR—East Lansing, Mich.—Michigan State College	1000	285.5	1050	Central					
	WKAU—Laconia, N. H. (Portable)—Laconia Radio Club.	50	224	1340						
	WKBB—Joliet, Ill.—Sanders Bros., 607 Jefferson St.	100	214.2	1400	Central					
	WKBE—Webster, Mass.—K. & B. Electric Co.	100	231	1300	Eastern					
	WKBG—Chicago, Ill.—(Portable) C. L. Carrell, 36 So. State St.	100	215.7	1390						
	WKRC—Cincinnati, Ohio.—Kodel Radio Corp., 507 E. Pearl St.	1000	325.9	920	Central					
			422.3	710	Central					
	WKY—Oklahoma, Okla.—E. C. Hull and H. S. Richards	100	275	1090	Central					
WL	WLAL—Tulsa, Okla.—First Christian Church	100	250	1200	Central					
	WLAP—Louisville, Ky.—W. V. Jordon, 306 W. Breckenridge St.	20	275	1090	Central					
	WLAX—Greencastle, Ind.—Greencastle Community Broadcast- ing Station	10	231	1300	Central					
	WLB—Minneapolis, Minn.—University of Minnesota	500	278	1080	Central					
	WLBL—Stevens Point, Wis.—Wisconsin Department of Markets	500	278	1080	Central					
	WLIB—Elgin, Ill.—Liberty Weekly	2500	302.8	990	Central					
	WLIT—Philadelphia, Pa.—Lit Bros.	500	394.5	760	Eastern					
	WLS—Chicago, Ill.—(Transmitter is in Crete, Ill.) Sears Roe- beck & Co.	1500	344.6	870	Central					
	WLTS—Chicago, Ill.—Lane Technical High School	100	258	1160	Central					
	WLW—Cincinnati, Ohio.—(Transmitter is in Harrison, Ohio) Crosley Radio Corp. Alfred & Cook Sts., Cincinnati, O.	5000	422.3	710	Central					
	WLWL—New York, N. Y.—Missionary Society of St. Paul the Apostle	1500	288.3	1040	Eastern					
WM	WMAC—Cazenovia, N. Y.—Clive B. Meredith	100	275	1090	Eastern					
	WMAF—Dartmouth, Mass.—Round Hills Radio Corporation.	1000	440.9	680	Eastern					
	WMAK—Lockport, N. Y.—Norton Laboratories	500	266	1130	Eastern					
	WMAL—Washington, D. C.—M. A. Leese Optical Co., 712 Eleventh Street	15	212.6	1410	Eastern					
	WMAN—Columbus, Ohio.—W. E. Heskett (1st Baptist Church)	50	278	1080	Central					
	WMAQ—Chicago, Ill.—Daily News	500	447.5	670	Central					
	WMAZ—St. Louis, Mo.—Kingshighway Presbyterian Church ..	100	248	1210	Central					
	WMAZ—Macon, Ga.—Mercer University	500	261	1150	Central					

Radio Call Letters	BROADCAST STATIONS Location and Name	Power Watts	Wave Length (Meters)	Frequency (Kilohertz)	Time at Station	Date Time Received	Dial 1	Dial 2	Dial 3
WM	WMBB—Chicago, Ill.—American Bond & Mortgage Co., 6201 Cottage Grove Ave.	500	250	1200	Central				
	WMBC—Detroit, Mich.—Hotel Addison, Mich. Broadcasting Co. (F G. Siegel)	100	256.4	1170	Central				
	WMBF—Miami Beach, Fla.—Fleetwood Hotel Corporation ..	500	384.4	780	Eastern				
	WMC—Memphis, Tenn.—Commercial Appeal	500	499.7	600	Central				
	WMCA—New York, N. Y.—(Transmitter is in Hoboken, N. J.) Greely Square Hotel Company	500	340.7	880	Eastern				
WN	WNAB—Boston, Mass.—Shepard Stores	100	250	1200	Eastern				
	WNAC—Boston, Mass.—Shepard Stores	500	280.2	1070	Eastern				
	WNAD—Norman, Okla.—University of Oklahoma	250	254	1180	Central				
	WNAL—Omaha, Neb.—Omaha Central High School	50	258	1160	Central				
	WNAT—Philadelphia, Pa.—Lenning Bros. Co.	100	250	1200	Eastern				
	WNAX—Yankton, S. Dak.—Dakota Radio Apparatus Co.	100	244	1230	Central				
	WNBH—New Bedford, Mass.—New Bedford Hotel, (Irving J. Vermilya and A. J. Lopez)	250	248	1210	Eastern				
	WNJ—Newark, N. J.—Radio Shop of Newark (Herman Lubinsky) 89 Lehigh Ave.	150	252	1190	Eastern				
	WNOX—Knoxville, Tenn.—Peoples Telephone & Telegraph Co.	500	268	1120	Central				
	WNYC—New York, N. Y.—City of New York, Dept. of Plants and Structures	1000	526	570	Eastern				
WO	WOAC—Lima, Ohio.—Page Organ Co.	50	261	1150	Central				
	WOAI—San Antonio, Tex.—Southern Equipment Co.	2000	394.5	760	Central				
	WOAN—Lawrenceburg, Tenn.—Jas. D. Vaughn	500	282.8	1060	Central				
	WOAW—Omaha, Nebr.—Woodmen of the World	1000	528	570	Central				
	WOAX—Trenton, N. J.—Franklyn J. Wolff	500	240	1250	Eastern				
	WOC—Davenport, Iowa.—Palmer School of Chiropractic	5000	483.6	620	Central				
	WOCG—Sycamore, Ill.—Triple Alliance Radio Station, 108 West State St.	10	205.4	1400	Central				
	WOCL—Jamestown, N. Y.—Hotel Jamestown	15	275	1090	Eastern				
	WODA—Paterson, N. J.—O'Dea Temple of Music	250	224	1340	Eastern				
	WOL—Ames, Iowa.—Iowa State College	750	270	1110	Central				
	WOK—Chicago, Ill.—(Transmitter is in Homewood, Ill.) Neutrowound Radio Mfg. Co., 1721 Prairie Ave.	5000	217.3	1380	Central				
	WOKO—New York, N. Y.—Otto Baur, 138 Dyckman St.	50	233	1290	Eastern				
	WOO—Philadelphia, Pa.—John Wanamaker	500	508.2	590	Eastern				
	WQQ—Kansas City, Mo.—Unity School of Christianity	1000	278	1080	Central				
	WOR—Newark, N. J.—L. Bamberger & Co.	500	405.2	740	Eastern				
	WORD—Batavia, Ill.—Peoples Pulpit Assn.	5000	275	1090	Central				
	WOS—Jefferson City, Mo.—Missouri State Marketing Bureau	500	440.9	680	Central				
	WOWL—New Orleans, La.—Owl Battery Co., 901 Carondelet Street.	10	270	1110	Central				
	WOWO—Fort Wayne, Ind.—Main Auto Supply Co., 213 West Main St.	500	227	1320	Central				
WP	WPAK—Agricultural College, N. D.—North Dakota Agricultural College	50	275	1090	Central				
	WPCC—Chicago, Ill.—North Shore Congregational Church ..	500	258	1160	Central				
	WPDQ—Buffalo, N. Y.—Hiram L. Turner, 121 Norwood Ave.	50	205.4	1460	Eastern				
	WPG—Atlantic City, N. J.—Municipality of Atlantic City	500	299.8	1000	Eastern				
	WPRC—Harrisburg, Pa.—Wilson Printing & Radio Co., Fifth and Keller Streets	100	215.7	1390	Eastern				
	WPSC—State College, Pa.—Pennsylvania State College	500	261	1150	Eastern				
WQ	WQAA—Parkersburg, Pa.—Horace A. Beale, Jr.	500	220	1360	Eastern				
	WQAE—Springfield, Vt.—Moore Radio News Station	50	246	1220	Eastern				
	WQAM—Miami, Fla.—Electrical Equipment Co., 42 Northwest Fourth St.	100	263	1140	Eastern				
	WQAN—Scranton, Pa.—Scranton Times.	100	250	1200	Eastern				
	WQAO—New York, N. Y.—Calvary Baptist Church	100	360	833	Eastern				



Radio Call Letters	BROADCAST STATIONS Location and Name	Power Watts	Wave Length (Meters)	Frequency (Kilocycles)	Time at Station	Date	Time Received	Dial 1	Dial 2	Dial 3
WQ	WQJ—Chicago, Ill.—Calumet Rainbo Broadcasting Co., Rainbo Gardens	500	447.5	670	Central					
WR	WRAF—Laport, Ind.—The Radio Club Inc.	100	224	1340	Central					
	WRAK—Escanaba, Mich.—Economy Light Co., 1105 Ludington Street	100	256	1170	Central					
	WRAM—Galesburg, Ill.—Lombard College	100	244	1230	Central					
	WRAV—Yellow Springs, Ohio.—Antioch College	100	263	1140	Central					
	WRAW—Reading, Pa.—Avenue Radio & Electric Shop (Horace D. Good), 460 Schuylkill.	10	238	1260	Eastern					
	WRAX—Gloucester City, N. J.—Flexon's Garage	500	268	1120	Eastern					
	WRBC—Valparaiso, Ind.—Immanuel Lutheran Church	500	278	1080	Central					
	WRC—Washington, D. C.—Radio Corporation of America	1000	468.5	640	Eastern					
	WRCO—Raleigh, N. C.—Wynne Radio Co., 226 1-2 Fayetteville Street.	100	252	1190	Eastern					
	WREC—Coldwater, Miss.—Wooten's Radio & Electric Co.	10	254	1180	Central					
	WREO—Lansing, Mich.—Reo Motor Car Co.	500	285.5	1050	Central					
	WRHM—Minneapolis, Minn.—Rosedale Hospital	50	262	1190	Central					
	WRK—Hamilton, Ohio.—Doron Bros. Electrical Co.	100	270	1110	Central					
	WRM—Urbana, Ill.—University of Illinois	500	273	1100	Central					
	WRMU—Richmond Hill, N. Y. MU-1 (Yacht) A. H. Grebe & Co.	100	236	1270	Eastern					
	WRNY—New York, N. Y.—Experimenter Publishing Co., 53 Park Place	500	258	1160	Eastern					
	WRR—Dallas, Tex.—City of Dallas, Police and Fire Signal Dpt.	500	246	1220	Central					
	WRST—Bay Shore, N. Y.—Radiotel Mfg. Co., 5 First Ave. ...	250	215.7	1390	Eastern					
	WRVA—Richmond, Va.—Larus & Brother Co.	1000	256	1170	Eastern					
	WRW—Tarrytown, N. Y.—Tarrytown Radio Research Laboratories, (Koenig Bros.)	500	273	1100	Eastern					
WS	WSAI—Cincinnati, Oh.—(Transmitter is in Mason, Ohio)—United States Playing Card Co., Cincinnati, Ohio ...	5000	325.9	920	Central					
	WSAJ—Grove City, Pa.—Grove City College	250	229	1310	Eastern					
	WSAN—Allentown, Pa.—Allentown Call Publishing Co.	100	229	1310	Eastern					
	WSAR—Fall River, Mass.—Doughty & Welch Electrical Co. ...	100	254	1180	Eastern					
	WSAU—Chesham, N. H.—Camp Marienfeld	10	229	1310	Eastern					
	WSAX—Chicago, Ill.—(Portable) Zenith Radio Corp., 332 South Michigan Avenue	100	268	1120						
	WSAZ—Pomeroy, Ohio.—Chase Electric Shop	50	244	1230	Eastern					
	WSB—Atlanta, Ga.—Atlanta Journal	1000	428.3	700	Central					
	WSBC—Chicago, Ill.—World Battery Co., 1219 So. Wabash Ave.	500	209.7	1430	Central					
	WSBF—St. Louis, Mo.—Stix, Baer & Fuller	250	273	1100	Central					
	WSBT—South Bend, Ind.—South Bend Tribune	250	275	1090	Central					
	WSDA—New York, N. Y.—The City Temple (Seventh Day Adventist Church), 130th St. Lenox Ave.	250	263	1140	Eastern					
	WSKC—Bay City, Mich.—World's Star Knitting Co.	100	261	1150	Central					
	WSM—Nashville, Tenn.—National Life & Accident Ins. Co. ...	1000	282.8	1060	Central					
	WSMB—New Orleans, La.—Saenger Amusement Co. and Maison Blanche Co.	500	319	940	Central					
	WSMH—Owosso, Mich.—Shattuck Music House, 207 Washington Street	20	240	1250	Central					
	WSMK—Dayton, Ohio.—S. M. K. Radio Corporation, 39 East Third Street	500	275	1090	Central					
	WSOE—Milwaukee, Wis.—School of Engineering of Milwaukee, 415 Marshall Street	500	246	1220	Central					
	WSRO—Hamilton, Ohio.—The Radio Co. (Harry W. Fahrlander)	100	252	1190	Central					
	WSUI—Iowa City, Iowa.—State University of Iowa	500	483.6	620	Central					
	WTAB—Fall River, Mass.—Fall River Daily Herald	100	266	1130	Eastern					
WT	WTAC—Johnstown, Pa.—Penn Traffic Co.	100	268	1120	Eastern					
	WTAD—Carthage, Ill.—Robt. E. Compton	50	236	1270	Central					

Radio Call Letters	BROADCAST STATIONS Location and Name	Power Watts	Wave Length (Meters)	Frequency (Kilocycles)	Time at Station	Date	Time Received	Dial 1	Dial 2	Dial 3
WT	WTAG—Worcester, Mass.—Worcester Telegram Pub. Co.	500	268	1120	Eastern					
	WTAL—Toledo, Ohio.—Toledo Radio & Electric Co., 316 Jackson St.	10	252	1190	Central					
	WTAM—Cleveland, Ohio.—Willard Storage Battery Co.	3500	389.4	770	Eastern					
	WTAP—Cambridge, Ill.—Cambridge Radio & Electric Co.	50	242	1240	Central					
	WTAQ—Osseo, Wis.—S. H. Van Gorden & Son	100	254	1180	Central					
	WTAR—Norfolk, Va.—Reliance Electric Co., 519 W. 21st St. ..	100	261	1150	Eastern					
	WTAT—Boston, Mass.—(Portable) Edison Electric Illuminating Co., 39 Boylston St.	100	244	1230	Eastern					
	WTAW—College Station, Tex.—Agricultural and Mechanical College of Texas	500	270	1110	Central					
	WTAX—Streator, Ill.—Williams Hardware Co., 115 So. Vermillion Street	50	231	1300	Central					
	WTAZ—Lambertville, N. J.—Thos. J. McGuire	15	261	1150	Eastern					
	WTG—Manhattan, Kans.—Kansas State Agricultural College	50	273	1100	Central					
	WTIC—Hartford, Conn.—Travelers Insurance Co.	500	348.6	860	Eastern					
WW	WWAD—Philadelphia, Pa.—Wright & Wright Inc., 2215 N. Broad street	250	250	1200	Eastern					
	WWAE—Plainfield, Ill.—Electric Park (Lawrence J. Crowley)	500	242	1240	Central					
	WWAO—Houghton, Mich.—Michigan College of Mines	250	263	1140	Central					
	WWGL—Richmond Hill, N. Y.—Radio Engineering Corp., 8501 One Hundred and Twenty Fourth Street	500	212.6	1410	Eastern					
	WWI—Dearborn, Mich.—Ford Motor Co.	500	266	1130	Central					
	WWJ—Detroit, Mich.—Detroit News	1000	352.7	850	Central					
	WWL—New Orleans, La.—Loyola University	100	275	1090	Central					

Additions, changes and eliminations of the foregoing list of Radio Broadcast Stations up to and including January 1st, 1926 given on page 176.

RADIO DISTRICTS OF U. S. AND CANADA

The supervision of radio in the United States is under the Department of Commerce. The country is divided into 9 Districts and all Broadcast Stations and Amateur sending stations are under the supervision of the Radio Inspectors, now called Supervisors of Radio. All complaints about interference; applications for licenses for transmitting stations (receiving stations are not subject to Government control) etc., should be addressed to the Supervisor of Radio of the District in which the writer is located.

The radio inspection districts are as follows:

1. Headquarters, Boston, Mass. (supervisor of radio, custom house): Maine, New Hampshire, Vermont, Massachusetts, Rhode Island, Connecticut.

2. Headquarters, New York, N. Y. (supervisor of radio, U. S. Sub-Treasury): New York (county of New York), Staten Island, Long Island, and counties on the Hudson River to and including Schenectady, Albany, and Rensselaer) and New Jersey (counties of Bergen, Passaic, Essex, Union, Middlesex, Monmouth, Hudson, and Ocean).

3. Headquarters, Baltimore, Md. (supervisor of radio, custom house): New Jersey (all counties not included in second district), Pennsylvania (counties of Philadelphia, Delaware, all counties south of the Blue Mountains, and Franklin County), Delaware, Maryland, Virginia, District of Columbia.

4. Headquarters, Atlanta, Ga. (supervisor of radio, Federal

Building): North Carolina, South Carolina, Georgia, Florida, Tennessee, Porto Rico.

5. Headquarters, New Orleans, La. (supervisor of radio, custom house): Alabama, Mississippi, Louisiana, Texas, Arkansas, Oklahoma, New Mexico.

6. Headquarters, San Francisco, Calif. (supervisor of radio, custom house): California, Hawaii, Nevada, Utah, Arizona.

7. Headquarters, Seattle, Wash. (supervisor of radio, 2301 L. C. Smith Building): Oregon, Washington, Alaska, Idaho, Montana, Wyoming.

8. Headquarters, Detroit, Mich. (supervisor of radio, Federal Building): New York (all counties not included in second district), Pennsylvania (all counties not included in third district), West Virginia, Ohio, Michigan (lower peninsula).

9. Headquarters, Chicago, Ill. (supervisor of radio, Federal Building): Indiana, Illinois, Wisconsin, Michigan (upper peninsula), Minnesota, Kentucky, Missouri, Kansas, Colorado, Iowa, Nebraska, South Dakota, North Dakota.

CANADA

District No. 1—Nova Scotia, New Brunswick and Prince Edward Island.

District No. 2—Province of Quebec.

District No. 3—Province of Ontario.

District No. 4—Manitoba, Saskatchewan and Alberta.

District No. 5—British Columbia, Yukon and Northwest Territories.

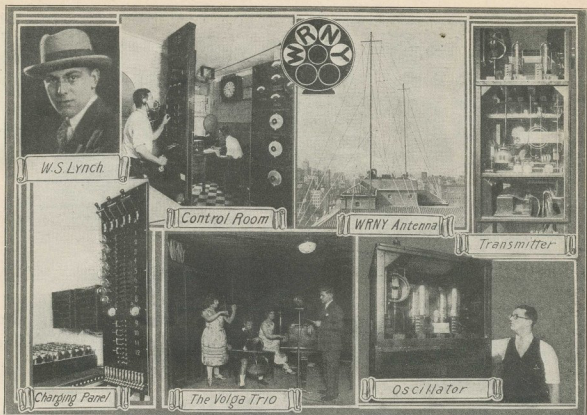

W.S. Lynch

Control Room

WRNY Antenna

Transmitter

Charging Panel

The Volga Trio

Oscillator



Chas. D. Isaacson

Pierre Remington

Anna Russo

Harvey W. Corbett

Lorna Lea

Lionko & Children Dancers

A.B. Bernie Orchestra



Started Apr 26, 1926.

RADIO BROADCAST STATIONS OF THE UNITED STATES

By Wavelengths and Frequencies

Wave Length (Meters)	Frequency (Kilocycles)	Call Letters	Location	Date	Time Received	Dial 1	Dial 2	Dial 3
202.6	1480	KFXB	Big Bear Lake, Cal.					
202.6	1480	WEHS	Evanston, Ill.					
202.6	1480	WIBS	Elizabeth, N. J.					
205.4	1460	KFVD	San Pedro, Cal.					
205.4	1460	KFXD	Logan, Utah					
205.4	1460	KFXV	Flagstaff, Ariz.					
205.4	1460	KFYF	Oxnard, Cal.					
205.4	1460	WCBR	Providence, R. I.					
205.4	1460	WFRL	Brooklyn, N. Y.					
205.4	1460	WIBK	Toledo, Ohio					
205.4	1460	WIBX	Utica, New York					
205.4	1460	WOCG	Sycamore, Ill.					
205.4	1460	WPDQ	Buffalo, N. Y.					
206.8	1450	KFWM	Oakland, Cal.					
206.8	1450	WABW	Wooster, Ohio					
206.8	1450	WJBA	Joliet, Ill.					
208.2	1440	KNRC	Los Angeles, Cal.					
209.7	1430	KDZB	Bakersfield, Cal.					
209.7	1430	KFVU	Eureka, Cal.					
209.7	1430	KFXC	Santa Maria, Cal.					
209.7	1430	WCWS	Providence, R. I.					
209.7	1430	WIBH	New Bedford, Mass.					
209.7	1430	WSBC	Chicago, Ill.					
211.1	1420	KFWO	Avalon, Cal.					
211.1	1420	WJBQ	Lewisburg, Pa.					
212.6	1410	KFWV	Portland, Oregon					
212.6	1410	KQP	Portland, Oregon					
212.6	1410	WMAL	Washington, D. C.					
212.6	1410	WWGL	Richmond Hill, N. Y.					
214.2	1400	KFWF	St. Louis, Mo.					
214.2	1400	KFWP	Brownsville, Tex.					
214.2	1400	WCLS	Joliet, Ill.					
214.2	1400	WKBB	Joliet, Ill.					
215.7	1390	KFQW	North Bend, Washington.					
215.7	1390	KFXJ	Denver, Colo.					
215.7	1390	WBBZ	Chicago, Ill.					
215.7	1390	WHBL	Logansport, Ind.					
215.7	1390	WHBR	Cincinnati, Ohio					
215.7	1390	WHBW	Philadelphia, Pa.					
215.7	1390	WIBJ	Chicago, Ill. (Portable)					
215.7	1390	WIBM	Chicago, Ill. (Portable)					
215.7	1390	WKBG	Chicago, Ill. (Portable)					
215.7	1390	WPRC	Harrisburg, Pa.					
215.7	1390	*WRST	Bay Shore, N. Y.					
217.3	1380	KFAF	San Jose, Cal.					
217.3	1380	WFKB	Chicago, Ill.					
217.3	1380	KFQU	Alma, Cal. (Holy City)					
217.3	1380	WJD	Granville, Ohio.					



A. F. Stanley

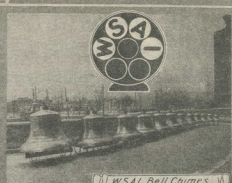

WSAI Bell Chimes



P. A. Greene



U.S. Playing Card Plant



Grace C. Rainie



Solo Studio



Harold A. Fall



Carpenter & Ingram



Wilson Wetherbee



A. W. Kanev



Lee Sims



Loos Brothers



Coon & Sanders Nighthawks



Harold H. Isbell

Wave Length (Meters)	Frequency (Kilocycles)	Call Letters	Location	Date	Time Received	Dial 1	Dial 2	Dial 3
217.3	1380	WOK	Chicago, Ill. (Transmitter in Homewood, Ill.).					
218.8	1370	KFJC	Junction City, Kans.					
218.8	1370	KFRW	Olympia, Wash.					
218.8	1370	KFVH	Manhattan, Kans.					
218.8	1370	WHBU	Anderson, Ind.					
218.8	1370	WIBI	Flushing, N. Y.					
218.8	1370	WJBI	Red Bank, N. J.					
218.8	1370	WJBP	Buffalo, N. Y.					
220	1360	KFOB	Burlingame, Cal.					
220	1360	KFUU	Oakland, Cal.					
220	1360	KJBS	San Francisco, Cal.					
220	1360	WIBW	Logansport, Ind.					
220	1360	WQAA	Parkersburg, Pa.					
222	1350	WBBW	Norfolk, Va.					
222	1350	WBES	Takoma Park, Md.					
222	1350	WHBD	Bellefontaine, Ohio					
222	1350	WHBF	Rock Island, Ill.					
222	1350	WHBH	Culver, Ind.					
222	1350	WIBC	St. Petersburg, Fla.					
222	1350	WIBG	Elkins Park, Pa.					
222	1350	WIBU	Poynette, Wis.					
224	1340	KFBC	San Diego, Cal.					
224	1340	KFBL	Everette, Wash.					
224	1340	KFQP	Iowa City, Ia.					
224	1340	KFUR	Ogden, Utah					
224	1340	KFVS	Cape Girardeau, Mo.					
224	1340	WJBG	Charlotte, N. C.					
224	1340	WKAV	Laconia, N. H. (Portable).					
224	1340	WODA	Paterson, N. J.					
224	1340	WRAF	Laport, Ind.					
226	1330	KFGQ	Boone, Iowa					
226	1330	KFKZ	Kirksville, Mo.					
226	1330	KFOR	David City, Neb.					
226	1330	KFQZ	Hollywood, Cal.					
226	1330	KFWI	So. San Francisco, Cal.					
226	1330	WBBM	Chicago, Ill.					
226	1330	WDAD	Nashville, Tenn.					
226	1330	WEBL	United States (Portable)					
226	1330	WEBM	United States (Portable)					
226	1330	WEBQ	Harrisburg, Ill.					
226	1330	WFBE	Seymour, Ind.					
226	1330	WIBO	Chicago, Ill.					
227	1320	KFVN	Welcome, Minn.					
227	1320	KFXM	Beaumont, Tex.					
227	1320	WDBK	Cleveland, Ohio.					
227	1320	WOWO	Ft. Wayne, Ind.					
229	1310	KFLV	Rockford, Ill.					
229	1310	KPPC	Pasadena, Cal.					
229	1310	WAIT	Taunton, Mass.					
229	1310	WBBL	Richmond, Va.					
229	1310	WCBC	Ann Arbor, Mich.					
229	1310	WCBM	Baltimore, Md.					
229	1310	WDBJ	Roanoke, Va.					
229	1310	WGBR	Marshfield, Wis.					

Wave Length (Meters)	Frequency (Kilocycles)	Call Letters	Location	Date	Times Received	Dial 1	Dial 2	Dial 3
229	1310	WSAJ	Grove City, Pa.					
229	1310	WSAN	Allentown, Pa.					
229	1310	WSAU	Chesham, N. H.					
231	1300	KDLR	Devils Lake, N. Dak.					
231	1300	KFDZ	Minneapolis, Minn.					
231	1300	KFOT	Wichita, Kans.					
231	1300	KFPR	Los Angeles, Cal.					
231	1300	KQW	San Jose, Cal.					
231	1300	KUT	Austin, Texas.					
231	1300	WBRE	Wilkes-Barre, Pa.					
231	1300	WCLO	Camp Lake, Wis.					
231	1300	WHBG	Harrisburg, Pa.					
231	1300	WHBK	Ellsworth, Me.					
231	1300	WIBZ	Montgomery, Ala.					
231	1300	WKBE	Webster, Mass.					
231	1300	WLAX	Greencastle, Ind.					
231	1300	WTAX	Streator, Ill.					
233	1290	KFEY	Kellogg, Idaho.					
233	1290	KFON	Long Beach, Cal.					
233	1290	WDEZ	Kingston, N. Y.					
233	1290	WHAG	Cincinnati, Ohio.					
233	1290	WHBM	Chicago, Ill. (Portable)					
233	1290	WHBQ	Memphis, Tenn.					
233	1290	WJBK	Ypsilanti, Mich.					
233	1290	WOKO	New York, N. Y.					
234	1280	KFUP	Denver, Colo.					
234	1280	KGTT	San Francisco, Cal.					
234	1280	KMJ	Fresno, Calif.					
234	1280	WEBE	Cambridge, Ohio.					
234	1280	WFBD	Philadelphia, Pa.					
234	1280	WFDF	Flint, Mich.					
234	1280	WGBM	Providence, R. I.					
234	1280	WGBQ	Menominee, Wis.					
234	1280	WHBJ	Fort Wayne, Ind.					
234	1280	WJBC	LaSalle, Ill.					
236	1270	KFLU	San Benito, Tex.					
236	1270	KFOO	Salt Lake City, Utah.					
236	1270	KFVG	Independence, Kans.					
236	1270	KFXE	Waterloo, Ia.					
236	1270	KWKC	Kansas City, Mo.					
236	1270	WBOQ	Richmond Hill, N. Y.					
236	1270	WCBQ	Nashville, Tenn.					
236	1270	WFBI	Camden, N. J.					
236	1270	WFBJ	Collegeville, Minn.					
236	1270	WGBF	Evansville, Ind.					
236	1270	WGBT	Greenville, S. C.					
236	1270	WGMU	Richmond Hill, N. Y. (Portable)					
236	1270	WIBA	Madison, Wis.					
236	1270	WRMU	Richmond Hill, N. Y. (Yacht)					
236	1270	WTAD	Carthage, Ill.					
238	1260	KFBS	Trinidad, Colo.					
238	1260	KFCB	Phoenix, Ariz.					
238	1260	KFWU	Pineville, La.					
238	1260	KFYJ	Houston, Texas					
238	1260	KMTR	Los Angeles, Cal.					

Wave Length (Meters)	Frequency (Kilocycles)	Call Letters	Location	Time Received	Dial 1	Dial 2	Dial 3
238	1260	WBBP	Petoskey, Mich.				
238	1260	WCUW	Worcester, Mass.				
238	1260	WHBN	St. Petersburg, Fla.				
238	1260	WHT	Chicago, Ill. (Transmitter in Deerfield, Ill.)				
238	1260	WRAW	Reading, Pa.				
240	1250	KFHL	Oskaloosa, Iowa				
240	1250	KFLX	Galveston, Texas				
240	1250	KFVE	St. Louis, Mo.				
240	1250	KFVI	Houston, Texas				
240	1250	KTAB	Oakland, Cal.				
240	1250	KZM	Oakland, Cal.				
240	1250	WABI	Bangor, Me.				
240	1250	WCAT	Rapid City, S. D.				
240	1250	WDBO	Winter Park, Fla.				
240	1250	WGBI	Scranton, Pa.				
240	1250	WHAP	New York, N. Y.				
240	1250	WKAD	E. Providence, R. I.				
240	1250	WOAX	Trenton, N. J.				
240	1250	WSMH	Owosso, Mich.				
242	1240	KFFP	Moberly, Mo.				
242	1240	KFOJ	Moberly, Mo.				
242	1240	KFPM	Greenville, Texas				
242	1240	KFRM	Fort Sill, Okla.				
242	1240	KFUJ	Breckenridge, Minn.				
242	1240	KFUM	Colorado Springs, Colo.				
242	1240	KFXH	El Paso, Texas				
242	1240	KSO	Clarinda, Iowa				
242	1240	WAGY	Philadelphia, Pa.				
242	1240	WBZA	Boston, Mass.				
242	1240	WCBH	Oxford, Miss.				
242	1240	WEBE	Superior, Wis.				
242	1240	WEBK	Grand Rapids, Mich.				
242	1240	WTAP	Cambridge, Ill.				
242	1240	WWAE	Plainfield, Ill.				
244	1230	KFVR	Denver, Colo.				
244	1230	KUOM	Missoula, Mont.				
244	1230	WAMD	Minneapolis, Minn.				
244	1230	WEBR	Buffalo, N. Y.				
244	1230	WGBB	Freeport, N. Y.				
244	1230	WNAX	Yankton, S. D.				
244	1230	WRAM	Galesburg, Ill.				
244	1230	WSAZ	Pomeroy, Ohio				
244	1230	WTAT	Boston, Mass. (Portable)				
246	1220	KDYI	Salt Lake City, Utah				
246	1220	KFJI	Astoria, Oregon				
246	1220	KFJY	Fort Dodge, Iowa				
246	1220	KFVW	San Diego, Cal.				
246	1220	KGY	Lacey, Wash.				
246	1220	WABX	Mount Clemens, Mich.				
246	1220	WEBD	Anderson, Ind.				
246	1220	WIBR	Weirton, W. Va.				
246	1220	WQAE	Springfield, Vt.				
246	1220	WRR	Dallas, Texas				
246	1220	WSOE	Milwaukee, Wis.				
248	1210	KFBK	Sacramento, Cal.				

5 14/13



Wave Length (Meters)	Frequency (Kilocycles)	Call Letters	Location	Date Received	Dial 1	Dial 2	Dial 3
248	1210	KFEC	Portland, Oregon				
248	1210	KFIF	Portland, Oregon				
248	1210	KFJB	Marshalltown, Iowa				
248	1210	KFOX	Omaha, Neb.				
248	1210	KFRB	Beeville, Texas				
248	1210	KFYR	Bismarck, N. D.				
248	1210	KWG	Stockton, Cal.				
248	1210	WAPI	Auburn, Ala.				
248	1210	WBRC	Birmingham, Ala.				
248	1210	WCSO	Springfield, Ohio				
248	1210	WEW	St. Louis, Mo.				
248	1210	WGAL	Lancaster, Pa.				
248	1210	WGBK	Johnstown, Pa.				
248	1210	WMAY	St. Louis, Mo.				
248	1210	WNBH	New Bedford, Mass.				
250	1200	KDPM	Cleveland, Ohio				
250	1200	KFBG	Tacoma, Wash.				
250	1200	KFDX	Shreveport, La.				
250	1200	KFVY	Albuquerque, N. Mex.				
250	1200	KFXF	Colorado Springs, Colo.				
250	1200	KGB	Tacoma, Wash.				
250	1200	KMO	Tacoma, Wash.				
250	1200	KUO	San Francisco, Cal.				
250	1200	WCAX	Burlington, Vt.				
250	1200	WFBC	Knoxville, Tenn.				
250	1200	WGES	Oak Park, Ill.				
250	1200	WHBA	Oil City, Pa.				
250	1200	WHBY	West De Pere, Wis.				
250	1200	WIAD	Philadelphia, Pa.				
250	1200	WLAL	Tulsa, Okla.				
250	1200	WMBB	Chicago, Ill.				
250	1200	WNAB	Boston, Mass.				
250	1200	WNAT	Philadelphia, Pa.				
250	1200	WQAN	Scranton, Pa.				
250	1200	WWAD	Philadelphia, Pa.				
252	1190	KFHA	Gunnison, Colo.				
252	1190	KFOY	St. Paul, Minn.				
252	1190	KFPL	Dublin, Texas				
252	1190	KFUV	Springfield, Mo.				
252	1190	KFWB	Hollywood, Cal.				
252	1190	KLS	Oakland, Cal.				
252	1190	KMA	Shenandoah, Iowa				
252	1190	KOCW	Chickasha, Okla.				
252	1190	KWUC	Le Mars, Iowa				
252	1190	WBBS	New Orleans, La.				
252	1190	WFBL	Syracuse, N. Y.				
252	1190	WGBX	Orono, Me.				
252	1190	WGCP	New York, N. Y. (Transmitter in Newark, N. J.).				
252	1190	WNJ	Newark, N. J.				
252	1190	WRCO	Raleigh, N. C.				
252	1190	WRHM	Minneapolis, Minn.				
252	1190	WSRO	Hamilton, Ohio				
252	1190	WTAL	Toledo, Ohio				
254	1180	KFEL	Denver, Colo.				
254	1180	KFJZ	Fort Worth, Texas				

Wave Length (Meters)	Frequency (Kilocycles)	Call Letters	Location	Date	Time Received	Dial 1	Dial 2	Dial 3
254	1180	KFLR	Albuquerque, N. Mex.					
254	1180	KFWH	Chico, Cal.					
254	1180	WABC	Asheville, N. C.					
254	1180	WCAJ	University Place, Neb.					
254	1180	WCBA	Allentown, Pa.					
254	1180	WEAI	Ithaca, N. Y.					
254	1180	WFBR	Baltimore, Md.					
254	1180	WFBZ	Galesburg, Ill.					
254	1180	WHBC	Canton, Ohio					
254	1180	WIAS	Burlington, Iowa					
254	1180	WJAK	Greentown, Ind.					
254	1180	WJBB	St. Petersburg, Fla.					
254	1180	WNAD	Norman, Okla.					
254	1180	WREC	Coldwater, Miss.					
254	1180	WSAR	Fall River, Mass.					
254	1180	WTAQ	Osseo, Wis.					
256	1170	KFCF	Walla Walla, Wash.					
256	1170	KFIQ	Yakima, Wash.					
256	1170	KFUS	Oakland, Cal.					
256	1170	KKE	Berkeley, Cal.					
256	1170	KTNT	Muscatine, Iowa					
256	1170	WBAX	Wilkes-Barre, Pa.					
256	1170	WBDC	Grand Rapids, Mich.					
256	1170	WCSH	Portland, Me.					
256	1170	WDCH	Hanover, N. H.					
256	1170	WDOD	Chattanooga, Tenn.					
256	1170	WEBT	Dayton, Ohio					
256	1170	WHBP	Johnstown, Pa.					
256	1170	WJBN	Sycamore, Ill.					
256	1170	WRAK	Escanaba, Mich.					
256	1170	WRVA	Richmond, Va.					
256.4	1170	WMBC	Detroit, Mich.					
258	1160	KFJX	Cedar Falls, Ia.					
258	1160	KFPW	Cartersville, Mo.					
258	1160	KFUL	Galveston, Texas					
258	1160	KOCH	Omaha, Neb.					
258	1160	WAAD	Cincinnati, Ohio					
258	1160	WADC	Akron, Ohio					
258	1160	WDBC	Lancaster, Pa.					
258	1160	WHEC	Rochester, N. Y.					
258	1160	WLTS	Chicago, Ill.					
258	1160	WNAL	Omaha, Neb.					
258	1160	WPCC	Chicago, Ill.					
258	1160	WRNY	New York, N. Y.					
258.6	1160	WAGM	Royal Oak, Mich.					
261	1150	KFAJ	Boulder, Colo.					
261	1150	KFJF	Oklahoma, Okla.					
261	1150	KFMR	Sioux City, Iowa					
261	1150	KFQA	St. Louis, Mo.					
261	1150	KFUT	Salt Lake City, Utah					
261	1150	KFWA	Ogden, Utah					
261	1150	KMOX	St. Louis, Mo.					
261	1150	KWKH	Kennonwood, La.					
261	1150	WABQ	Haverford, Pa.					
261	1150	WARC	Medford Hillside, Mass.					
261	1150	WDAY	Fargo, N. D.					

Wave Length (Meters)	Frequency (Kilocycles)	Call Letters	Location	Date	Time Received	Dial 1	Dial 2	Dial 3
261	1150	WDBR	Boston, Mass.					
261	1150	WEAM	No. Plainfield, N. J.					
261	1150	WKAF	Milwaukee, Wis.					
261	1150	WMAZ	Macon, Ga.					
261	1150	WOAC	Lima, Ohio					
261	1150	WPSC	State College, Pa.					
261	1150	WSKC	Bay City, Mich.					
261	1150	WTAR	Norfolk, Va.					
261	1150	WTAZ	Lambertville, N. J.					
263	1140	KFJR	Portland, Oregon					
263	1140	KFMW	Houghton, Mich.					
263	1140	KFNF	Shenandoah, Iowa					
263	1140	KFQB	Fort Worth, Texas					
263	1140	KTBR	Portland, Oregon					
263	1140	WABR	Toledo, Ohio					
263	1140	WBPI	New York, N. Y. (Transmitter is in Newark, N. J.)					
263	1140	WCAD	Canton, N. Y.					
263	1140	WCAR	San Antonio, Texas					
263	1140	WCBE	New Orleans, La.					
263	1140	WDAG	Amarillo, Texas					
263	1140	WEBZ	Savannah, Ga.					
263	1140	WHAT	Minneapolis, Minn.					
263	1140	WIBV	Henderson, N. C.					
263	1140	WQAM	Miami, Fla.					
263	1140	WRAV	Yellow Springs, Ohio					
263	1140	WSDA	New York, N. Y.					
263	1140	WWAO	Houghton, Mich.					
266	1130	KFPY	Spokane, Wash.					
266	1130	KFRY	State College, N. Mex.					
266	1130	KFWD	Arkadelphia, Ark.					
266	1130	KLZ	Denver, Colo.					
266	1130	WABB	Harrisburg, Pa.					
266	1130	WBCN	Chicago, Ill.					
266	1130	WCAH	Columbus, Ohio					
266	1130	WENR	Chicago, Ill.					
266	1130	WGHB	Clearwater, Fla.					
266	1130	WHAV	Wilmington, Del.					
266	1130	WMAK	Lockport, N. Y.					
266	1130	WTAB	Fall River, Mass.					
266	1130	WWI	Dearborn, Mich.					
268	1120	KFEQ	Oak, Nebr.					
268	1120	KFGC	Baton Rouge, La.					
268	1120	KFRC	San Francisco, Cal.					
268	1120	WAAB	New Orleans, La.					
268	1120	WBBY	Charleston, S. C.					
268	1120	WCBG	Pascagoula, Miss.					
268	1120	WDRC	New Haven, Conn.					
268	1120	WEAH	Wichita, Kans.					
268	1120	WEBW	Beloit, Wis.					
268	1120	WFBM	Indianapolis, Ind.					
268	1120	WJAM	Cedar Rapids, Iowa					
268	1120	WNOX	Knoxville, Tenn.					
268	1120	WRAX	Gloucester City, N. J.					
268	1120	WSAX	Chicago, Ill. (Portable)					
268	1120	WTAC	Johnstown, Pa.					

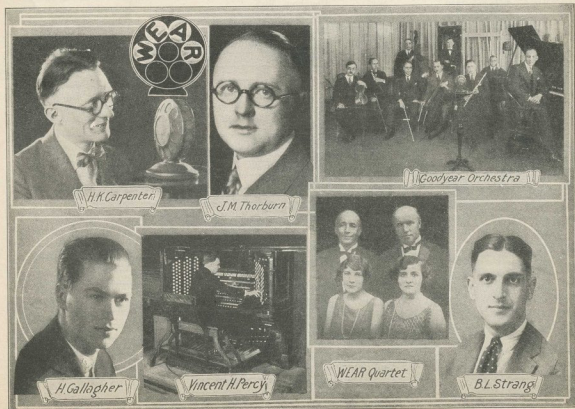

Wave Length (Meters)	Frequency (Kilocycles)	Call Letters	Location	Date	Time Received	Dial 1	Dial 2	Dial 3
268	1120	WTAG	Worcester, Mass.					
270	1110	KFBU	Laramie, Wyoming					
270	1110	KFGH	Stanford University, Cal.					
270	1110	WBAO	Decatur, Ill.					
270	1110	WDBE	Atlanta, Ga.					
270	1110	WEAN	Providence, R. I.					
270	1110	WEAY	Houston, Texas					
270	1110	WGHP	Detroit, Mich.					
270	1110	WGST	Atlanta, Ga.					
270	1110	WJAG	Norfolk, Nebr.					
270	1110	WJBL	Decatur, Ill.					
270	1110	WOI	Ames, Iowa					
270	1110	WOWD	New Orleans, La.					
270	1110	WRK	Hamilton, Ohio					
270	1110	WTAW	College Station, Texas					
273	1100	KFAD	Phoenix, Ariz.		5 17 18			
273	1100	KFDY	Brookings, S. Dak.					
273	1100	KFIZ	Fondulac, Wis.					
273	1100	KFKA	Greeley, Colo.					
273	1100	KFLZ	Atlantic, Iowa					
273	1100	KHQ	Spokane, Wash.					
273	1100	WBAA	West Lafayette, Ind.					
273	1100	WBBR	Rossville, N. Y.					
273	1100	WDAE	Tampa, Fla.					
273	1100	WEBJ	New York, N. Y.					
273	1100	WFAM	St. Cloud, Minn.					
273	1100	WFBH	New York, N. Y.					
273	1100	WHK	Cleveland, Ohio					
273	1100	WIL	St. Louis, Mo.					
273	1100	WRM	Urbana, Ill.					
273	1100	WRW	Tarrytown, N. Y.					
273	1100	WSBF	St. Louis, Mo.					
273	1100	WTG	Manhattan, Kans.					
275	1090	KFBB	Harve, Mont.					
275	1090	KFFY	Alexandria, La.					
275	1090	KFKU	Lawrence, Kans.					
275	1090	KFSG	Los Angeles, Cal.					
275	1090	KQV	Pittsburgh, Pa.					
275	1090	WABZ	New Orleans, La.					
275	1090	WAFD	Port Huron, Mich.					
275	1090	WBAK	Harrisburg, Pa.					
275	1090	WBT	Charlotte, N. C.					
275	1090	WCAC	Mansfield, Conn.					
275	1090	WCAO	Baltimore, Md.					
275	1090	WCEE	Elgin, Ill.					
275	1090	WEAU	Sioux City, Iowa					
275	1090	WFAV	Lincoln, Neb.					
275	1090	WHAD	Milwaukee, Wis.					
275	1090	WHAR	Atlantic City, N. J.					
275	1090	WJAS	Pittsburgh, Pa.					
275	1090	WKY	Oklahoma, Okla.					
275	1090	WLAP	Louisville, Ky.					
275	1090	WMAC	Cazenovia, N. Y.					
275	1090	WOCL	Jamestown, N. Y.					
275	1090	WORD	Batavia, Ill.					
275	1090	WPAK	Agricultural College, N. D.					

Wave Length (Meters)	Frequency (Kilocycles)	Call Letters	Location	Date	Time Received	Dial 1	Dial 2	Dial 3
275	1090	WSBT	South Bend, Ind.					
275	1090	WSMK	Dayton, Ohio					
275	1090	WWL	New Orleans, La.					
278	1080	KFDD	Boise, Idaho					
278	1080	KFJM	Grand Forks, N. D.					
278	1080	KOIL	Council Bluffs, Iowa					
278	1080	KUSD	Vermilion, S. D.					
278	1080	KWCR	Cedar Rapids, Iowa					
278	1080	KWWG	Brownsville, Texas					
278	1080	WAAF	Chicago, Ill.					
278	1080	WAAW	Omaha, Nebr.					
278	1080	WABO	Rochester, N. Y.					
278	1080	WCAU	Philadelphia, Pa.					
278	1080	WDZ	Tuscola, Ill.					
278	1080	WFBG	Altoona, Pa.					
278	1080	WGBC	Memphis, Tenn.					
278	1080	WGBU	Fufford-by-the-Sea, Fla.					
278	1080	WHAM	Rochester, N. Y.					
278	1080	WHDI	Minneapolis, Minn.					
278	1080	WLB	Minneapolis, Minn.					
278	1080	WLBL	Stevens Point, Wis.					
278	1080	WMAN	Columbus, Ohio					
278	1080	WOQ	Kansas City, Mo.					
278	1080	WRBC	Valparaiso, Ind.					
280.2	1070	WNAC	Boston, Mass.					
282.8	1060	KFAU	Boise, Idaho					
282.8	1060	KFDJ	Corvallis, Oregon					
282.8	1060	WOAN	Lawrenceburg, Tenn.					
282.8	1060	WSM	Nashville, Tenn.					
285.5	1050	WEMC	Berrien Springs, Mich.					
285.5	1050	WKAR	East Lansing, Mich.					
285.5	1050	WREO	Lansing, Mich.					
288.3	1040	KFKX	Hastings, Neb.					
288.3	1040	WLWL	New York, N. Y.					
293.9	1020	KTBI	Los Angeles, Cal.					
293.9	1020	WAIU	Columbus, Ohio					
293.9	1020	WEAO	Columbus, Ohio					
296.9	1010	KPRC	Houston, Texas					
299.8	1000	KFMQ	Fayetteville, Ark.					
299.8	1000	KSL	Salt Lake City, Utah					
299.8	1000	WPG	Atlantic City, N. J.					
302.8	990	WGN	Chicago, Ill.					
302.8	990	WLIB	Elgin, Ill.					
305.9	980	KTCL	Seattle, Wash.					
305.9	980	WJAR	Providence, R. I.					
309.1	970	KDKA	Pittsburgh, Pa. (Transmitter is in East Pittsburgh, Pa.)					
315.6	950	KFDM	Beaumont, Texas					
315.6	950	KPSN	Pasadena, Cal.					
315.6	950	WAHG	Richmond Hill, N. Y.					
315.6	950	WGBS	New York, N. Y.					
319	940	WGR	Buffalo, N. Y.					
319	940	WSMB	New Orleans, La.					
322.4	930	KOA	Denver, Colo.					
322.4	930	WJAZ	Chicago, Ill. (Transmitter in Mount Prospect, Ill.)					
325.9	920	WKRC	Cincinnati, Ohio					

Wave Length (Meters)	Frequency (Kilocycles)	Call Letters	Location	Date	Time Received	Dial 1	Dial 2	Dial 3
325.9	920	WSAI	Cincinnati, Ohio (Transmitter is in Mason, Ohio).					
331.1	900	WBZ	Springfield, Mass.					
336.9	890	KFMX	Northfield, Minn.					
336.9	890	KNX	Los Angeles, Cal.					
336.9	890	WCAL	Northfield, Minn.					
336.9	890	WJAX	Jacksonville, Fla.					
340.7	880	KFAB	Lincoln, Nebr.					
340.7	880	KSAC	Manhattan, Kans.					
340.7	880	WMCA	New York, N. Y. (Transmitter is in Hoboken, N. J.).					
344.6	870	WCBD	Zion, Ill.					
344.6	870	WLS	Chicago, Ill. (Transmitter is in Crete, Ill.).					
348.6	860	KOB	State College, N. Mex.					
348.6	860	KWSC	Pullman, Wash.					
348.6	860	WTIC	Hartford, Conn.					
352.7	850	WJAD	Waco, Tex.					
352.7	850	WWJ	Detroit, Mich.					
360	833	WQAO	New York, N. Y.					
361.2	830	KGO	Oakland, Cal.					
361.2	830	WHN	New York, N. Y.					
365.6	820	WDAF	Kansas City, Mo.					
365.6	820	WHB	Kansas City, Mo.					
370.2	810	WJJD	Mooseheart, Ill.					
370.2	810	WEBH	Chicago, Ill.					
374.8	800	KTBS	Hot Springs, Ark.					
374.8	800	KVOO	Bristow, Okla.					
374.8	800	WBAL	Baltimore, Md.					
379.5	790	WGY	Schenectady, N. Y.					
379.5	790	WHAZ	Troy, N. Y.					
384.4	780	KJR	Seattle, Wash.					
384.4	780	WMBF	Miami Beach, Fla.					
389.4	770	WEAR	Cleveland, Ohio					
389.4	770	WTAM	Cleveland, Ohio					
394.5	760	WOAI	San Antonio, Texas					
394.5	760	WFI	Philadelphia, Pa.					
394.5	760	WLIT	Philadelphia, Pa.					
399.8	750	WHAS	Louisville, Ky.					
405.2	740	KHJ	Los Angeles, Cal.					
405.2	740	WJY	New York, N. Y.					
405.2	740	WOR	Newark, N. J.					
416.4	720	WCCO	St. Paul,—Minneapolis, Minn.					
422.3	710	WKRC	Cincinnati, Ohio					
422.3	710	WLW	Cincinnati, Ohio (Transmitter is in Harrison, Ohio.).					
428.3	700	KPO	San Francisco, Cal.					
428.3	700	WSB	Atlanta, Ga.					
434.5	690	NAA	Arlington, Va.					
440.9	680	KLDS	Independence, Mo.					
440.9	680	WDWF	Cranston, R. I.					
440.9	680	WMAF	Dartmouth, Mass.					
440.9	680	WOS	Jefferson City, Mo.					
447.5	670	WMAQ	Chicago, Ill.					
447.5	670	WQJ	Chicago, Ill.					
454.3	660	KFOA	Seattle, Wash.					

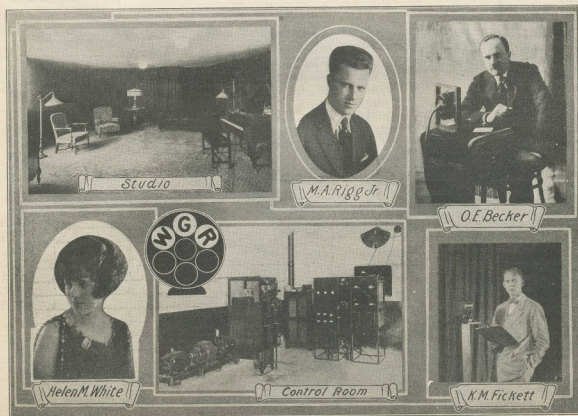

Wave Length (Meters)	Frequency (Kilocycles)	Call Letters	Location	Date	Mines Received	Dial 1	Dial 2	Dial 3
454.3	660	KTW	Seattle, Wash.					
454.3	660	WJZ	New York, N. Y.					
461.3	650	WCAE	Pittsburgh, Pa.					
468.5	640	KFI	Los Angeles, Cal.					
468.5	640	WCAP	Washington, D. C.					
468.5	640	WRC	Washington, D. C.					
475.9	630	WBAP	Fort Worth, Tex.					
475.9	630	WEEI	Boston, Mass.					
475.9	630	WFAA	Dallas, Texas		4 25		67	
483.6	620	WOC	Davenport, Ia.					
483.6	620	WSUI	Iowa City, Iowa					
491.5	610	KGW	Portland, Oregon					
491.5	610	WEAF	New York, N. Y.					
499.7	600	KFRU	Columbia, Mo.					
499.7	600	WMC	Memphis, Tenn.					
508.2	590	KLX	Oakland, Cal.					
508.2	590	WIP	Philadelphia, Pa.					
508.2	590	WOO	Philadelphia, Pa.					
516.9	580	WCX	Pontiac, Mich.					
516.9	580	WJR	Detroit, Mich. (Transmitter is in Pontiac, Mich.)					
526	570	WHO	Des Moines, Iowa					
526	570	WNYC	New York, N. Y.					
526	570	WOAW	Omaha, Nebr.					
535.4	560	KYW	Chicago, Ill.					
535.4	560	WHA	Madison, Wis.					
545.1	550	KFUO	St. Louis, Mo.					
545.1	550	KSD	St. Louis, Mo.					

All About Standard Time

The United States adopted standard time in 1883, on the initiative of the American Railway Association, and at noon of November 18th, 1883, the telegraphic time signals sent out daily from the Naval Observatory at Washington were changed to the new system, according to which the meridians of 75°, 90°, 105°, and 120° west from Greenwich became the time meridians of Eastern, Central, Mountain, and Pacific standard time respectively.

United States standard Eastern time is used from the Atlantic Ocean to a line through Toledo, Monroeville, Mansfield and Newark, O.; thence through Huntington, W. Va.; Norton, Va.; Johnson City, Tenn.; Asheville, N. C. Atlanta and Macon, Ga.; and Apalachicola, Fla. U. S. standard Central time is used from this first line to a line through Mandan, N. D.; Pierre, S. D.; McCook, Neb.; Dodge City, Kans., and along west line of Okla., and Tex.; standard Mountain time is used from the second line to a line that forms the western boundary of Mont., thence follows the Salmon River westward, the western boundary of Idaho southward, the southern boundary of Idaho eastward, and thence passes southward through Ogden and Salt Lake City, Utah; Parker and Yuma, Ariz. U. S. standard Pacific time is used from the third line to the Pacific Ocean.

Almost all countries throughout the world use standard time that differs from Greenwich time by a whole number of hours or half-hours; a few countries, however, use standard time based on the longitude of their national observatories.

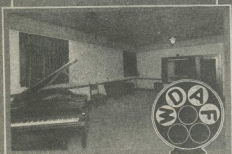

Broadcasting Room
W D A F



H. D. Fitzer



Trion Ensemble



C. R. Randall

L.J. Gallo Quartette

Station W3MB

Dixie Novelty Orchestra

Mildred Butz

Studio



Marie Morgott

Eddie Loftus

Ziegler Sisters

Corinne Jordan

Charlie Garland

STX Orchestra

Fred Teske

RADIO BROADCAST STATIONS OF THE UNITED STATES By States and Cities

STATES	CITIES	Call Letters	Wave Length (Meters)	Date	Time Received	Dial 1	Dial 2	Dial 3
ALABAMA	Auburn	WAPI	248					
"	Birmingham	WBRC	248					
"	Montgomery	WIBZ	231					
ARIZONA	Flagstaff	KFXY	205.4					
"	Phoenix	KPAD	273					
"	Phoenix	KFCB	238					
ARKANSAS	Arkadelphia	KFWD	266					
"	Fayetteville	KFMQ	299.8					
"	Hot Springs	KTHS	374.8					
CALIFORNIA	Alma (Holy City)	KFQU	217.3					
"	Avalon	KFWO	211.1					
"	Bakersfield	KDZB	209.7					
"	Berkeley	KRE	256					
"	Big Bear Lake	KFXB	202.6					
"	Burlingame	KFOB	220					
"	Chico	KFWH	254					
"	Eureka	KFVU	209.7					
"	Fresno	KMJ	234					
"	Hollywood	KFQZ	226					
"	Hollywood	KFWB	252					
"	Long Beach	KFON	233					
"	Los Angeles	KFI	468.5					
"	Los Angeles	KFPR	231					
"	Los Angeles	KFSG	275					
"	Los Angeles	KHJ	405.2					
"	Los Angeles	KMTR	238					
"	Los Angeles	KNRC	208.2					
"	Los Angeles	KNX	336.9					
"	Los Angeles	KTBI	293.9					
"	Oakland	KFUS	256					
"	Oakland	KFUU	220					
"	Oakland	KFWM	206.8					
"	Oakland	KGO	361.2					
"	Oakland	KLS	252					
"	Oakland	KLX	508.2					
"	Oakland	KTAB	240					
"	Oakland	KZM	240					
"	Oxnard	KFYF	205.4					
"	Pasadena	KPPC	229					
"	Pasadena	KPSN	315.6					
"	Sacramento	KFBK	248					
"	San Diego	KFBC	224					
"	San Diego	KFVW	246					
"	San Francisco	KFRC	268					
"	San Francisco	KGTT	234					
"	San Francisco	KJBS	220					
"	San Francisco	KFO	428.3					
"	San Francisco	KUO	250					
"	San Jose	KFAF	217.3					

STATES	CITIES	Call Letters	Wave Length (Meters)	Date	Time Received	Dial 1	Dial 2	Dial 3
CALIFORNIA	San Jose	KQW	231					
"	San Pedro	KFVD	205.4					
"	Santa Maria	KFXC	209.7					
"	So. San Francisco	KFWI	226					
"	Stanford University	KFGH	270					
"	Stockton	KWG	248					
COLORADO	Boulder	KFAJ	261					
"	Colorado Springs	KFUM	242					
"	Colorado Springs	KFXF	250					
"	Denver	KFEL	254					
"	Denver	KFUP	234					
"	Denver	KFVR	244					
"	Denver	KFXJ	215.7					
"	Denver	KLZ	266					
"	Denver	KOA	322.4					
"	Greeley	KFKA	273					
"	Gunnison	KFHA	252					
"	Trinidad	KFBS	238					
CONNECTICUT	Hartford	WTIC	348.6					
"	Mansfield	WCAC	275					
"	New Haven	WDRG	268					
DELAWARE	Wilmington	WHAU	266					
DIST. OF COLUMBIA	Washington	WCAP	468.5					
"	Washington	WMAL	212.6					
"	Washington	WRC	468.5					
FLORIDA	Clearwater	WGHB	236					
"	Fulford-by-the-Sea	WGBU	278					
"	Jacksonville	WJAX	336.9					
"	Miami	WQAM	263					
"	Miami Beach	WMBF	384.4					
"	St. Petersburg	WHBN	238					
"	St. Petersburg	WIBC	222					
"	St. Petersburg	WJBB	254					
"	Tampa	WDAE	273					
"	Winter Park	WDBO	240					
GEORGIA	Atlanta	WDBE	270					
"	Atlanta	WGST	270					
"	Atlanta	WSB	428.3					
"	Macon	WMAZ	261					
"	Savannah	WEBZ	263					
IDAHO	Boise	KFAU	282.8					
"	Boise	KFDD	278					
"	Kellogg	KFEY	233					
ILLINOIS	Batavia	WORD	275					
"	Cambridge	WTAP	242					
"	Carthage	WTAD	236					
"	Chicago	KYW	535.4					
"	Chicago	WAAF	278					
"	Chicago	WBBM	226					
"	Chicago	WBBZ	215.7					
"	Chicago	WBCN	266					
"	Chicago	WEBH	370.2					
"	Chicago	WENR	266					
"	Chicago	WFKB	217.3					
"	Chicago	WGN	302.8					
"	Chicago	WHBM	233					

STATES	CITIES	Call Letters	Wave Length (Meters)	Date	Time Received	Dial 1	Dial 2	Dial 3
ILLINOIS	Chicago	WHT	238					
"	Chicago	WIBJ	215.7					
"	Chicago	WIBM	215.7					
"	Chicago	WIBO	226					
"	Chicago	WJAZ	322.4					
"	Chicago	WKBG	215.7					
"	Chicago	WLS	344.6					
"	Chicago	WLTS	258					
"	Chicago	WMAQ	447.5					
"	Chicago	WMBB	250					
"	Chicago	WOK	217.3					
"	Chicago	WPCC	258					
"	Chicago	WQJ	447.5					
"	Chicago	WSAX	268					
"	Chicago	WSBC	209.7					
"	Decatur	WBAO	270					
"	Decatur	WJBL	270					
"	Elgin	WCEE	275					
"	Elgin	WLIB	302.8					
"	Evanston	WEHS	202.6					
"	Galesburg	WFBZ	254					
"	Galesburg	WRAM	244					
"	Harrisburg	WEBQ	226					
"	Joliet	WCLS	214.2					
"	Joliet	WJBA	206.8					
"	Joliet	WKBB	214.2					
"	LaSalle	WJBC	234					
"	Moosehart	WJJD	370.2					
"	Oak Park	WGES	250					
"	Plainfield	WVAE	242					
"	Rockford	KFLV	229					
"	Rock Island	WHBF	222					
"	Streator	WTAX	231					
"	Sycamore	WJBN	256					
"	Sycamore	WOCG	205.4					
"	Tuscola	WDZ	278					
"	Urbana	WRM	273					
"	Zion	WCBD	344.6					
INDIANA	Anderson	WEBD	246					
"	Anderson	WHBU	218.8					
"	Culver	WHBH	222					
"	Evansville	WGBF	236					
"	Fort Wayne	WHBJ	234					
"	Fort Wayne	WOWO	227					
"	Greencastle	WLAX	231					
"	Greentown	WJAK	254					
"	Indianapolis	WFBM	268					
"	Laport	WRAF	224					
"	Logansport	WHBL	215.7					
"	Logansport	WIBW	220					
"	Seymour	WFBE	226					
"	South Bend	WSBT	275					
"	Valparaiso	WRBC	278					
"	West Lafayette	WBAA	273					
IOWA	Ames	WOI	270					
"	Atlantic	KFLZ	273					

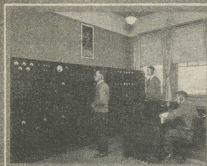

Control Room



Antenna System



Studio at Night



Staff and Studio



Concert Studio

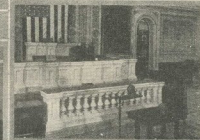

H. I. Millholland

U.S. Marine Band
WCAPStudio A
WCAPHouse of Representatives
WCAPM. E. Vogt
WOOH. Ridley & H. Golden
WOOW. N. Nassau
WOO

STATES	CITIES	Call Letters	Wave Length (Meters)	Date	Time Received	Dial 1	Dial 2	Dial 3
IOWA	Boone	KFGQ	236					
"	Burlington	WIAS	254					
"	Cedar Falls	KFJX	258					
"	Cedar Rapids	KWCR	278					
"	Cedar Rapids	WJAM	268					
"	Clarinda	KSO	242					
"	Council Bluffs	KOIL	278					
"	Davenport	WOC	483.6					
"	Des Moines	WHO	526					
"	Fort Dodge	KFJY	246					
"	Iowa City	KFQP	224					
"	Iowa City	WSUI	483.6					
"	Le Mars	KWUC	252					
"	Marshalltown	KFJB	248					
"	Muscatine	KTNT	256					
"	Oskaloosa	KPHL	240					
"	Shenandoah	KFNF	263					
"	Shenandoah	KMA	252					
"	Sioux City	KFMR	261					
"	Sioux City	WEAU	275					
"	Waterloo	KFXE	236					
KANSAS	Independence	KFVG	236					
"	Junction City	KFJC	218.8					
"	Lawrence	KFKU	275					
"	Manhattan	KFVH	218.8					
"	Manhattan	KSAC	340.7					
"	Manhattan	WTG	273					
"	Wichita	KFOT	231					
"	Wichita	WEAH	268					
KENTUCKY	Louisville	WHAS	399.8					
"	Louisville	WLAP	275					
LOUISIANA	Alexandria	KFFY	275					
"	Baton Rouge	KFGC	268					
"	Kennerwood	KWKH	261					
"	New Orleans	WAAB	268					
"	New Orleans	WABZ	275					
"	New Orleans	WBBS	252					
"	New Orleans	WCBE	263					
"	New Orleans	WOWL	270					
"	New Orleans	WSMB	319					
"	New Orleans	WWL	275					
"	Pineville	KFWU	238					
"	Shreveport	KFDX	250					
MAINE	Bangor	WABI	240					
"	Ellsworth	WHBK	231					
"	Orono	WGBX	252					
"	Portland	WCSH	256					
MARYLAND	Baltimore	WBAL	374.8					
"	Baltimore	WCAO	275					
"	Baltimore	WCBM	229					
"	Baltimore	WFBR	254					
"	Tokoma Park	WBES	222					
MASSACHUSETTS	Boston	WBZA	242					
"	Boston	WDBR	261					
"	Boston	WEEL	475.9					

STATES	CITIES	Call Letters	Wave Length (Meters)	Date	Time Received	Dial 1	Dial 2	Dial 3
MASSACHUSETTS	Boston	WNAB	250					
"	Boston	WNAC	280.2					
"	Boston	WTAT	244					
"	Dartmouth	WMAF	440.9					
"	Fall River	WSAR	254					
"	Fall River	WTAB	266					
"	Medford Hillside	WARC	261					
"	New Bedford	WIBH	209.7					
"	New Bedford	WNBH	248					
"	Springfield	WBZ	331.1					
"	Taunton	WAIT	229					
"	Webster	WKBE	231					
"	Worcester	WCUW	238					
"	Worcester	WTAG	268					
MICHIGAN	Ann Arbor	WCBC	229					
"	Bay City	WSKC	261					
"	Berrien Springs	WEMC	285.5					
"	Dearborn	WWI	266					
"	Detroit	WGHP	270					
"	Detroit	WJR	516.9					
"	Detroit	WMBC	256.4					
"	Detroit	WWJ	352.7					
"	East Lansing	WKAK	285.5					
"	Escanaba	WRAK	256					
"	Flint	WFDF	234					
"	Grand Rapids	WBDC	256					
"	Grand Rapids	WEBK	242					
"	Houghton	KFMW	263					
"	Houghton	WWAO	263					
"	Lansing	WREO	285.5					
"	Mount Clemens	WABX	246					
"	Owosso	WSMH	246					
"	Petosky	WBBP	238					
"	Pontiac	WCX	516.9					
"	Port Huron	WAFD	275					
"	Royal Oak	WAGM	258.6					
"	Ypsilanti	WJBK	233					
MINNESOTA	Breckenridge	KFUJ	242					
"	Collegeville	WFBJ	236					
"	Minneapolis	KFDZ	231					
"	Minneapolis	WAMD	244					
"	Minneapolis	WHAT	263					
"	Minneapolis	WHDI	278					
"	Minneapolis	WLB	278					
"	Minneapolis	WRHM	252					
"	Northfield	KFM	336.9					
"	Northfield	WCAL	336.9					
"	St. Cloud	WFAM	273					
"	St. Paul	KFOY	252					
"	St. Paul-Minneapolis	WCCO	416.4					
"	Welcome	KFVN	227					
MISSISSIPPI	Coldwater	WREC	254					
"	Oxford (near)	WCBH	242					
"	Pascagoula	WCBG	268					
MISSOURI	Cape Girardeau	KFVS	224					
"	Carterville	KFPW	258					

STATES	CITIES	Call Letters	Wave Length (Meters)	Date	Time Received	Dial 1	Dial 2	Dial 3
MISSOURI	Columbia	KFRU	499.7					
"	Independence	KLDS	440.9					
"	Jefferson City	WOS	440.9					
"	Kansas City	KWKC	236					
"	Kansas City	WDAF	365.6					
"	Kansas City	WHB	365.6					
"	Kansas City	WOQ	278					
"	Kirksville	KFKZ	226					
"	Moberly	KFFP	242					
"	Moberly	KFOJ	242					
"	St. Louis	KFQA	261					
"	St. Louis	KFUO	545.1					
"	St. Louis	KFVE	240					
"	St. Louis	KFWF	214.2					
"	St. Louis	KMOX	261					
"	St. Louis	KSD	545.1					
"	St. Louis	WEW	248					
"	St. Louis	WIL	273					
"	St. Louis	WMAY	248					
"	St. Louis	WSBF	273					
"	Springfield	KFUV	252					
MONTANA	Harve	KFBB	275					
"	Missoula	KUOM	244					
NEBRASKA	David City	KFOR	226					
"	Hastings	KFKX	288.3					
"	Lincoln	KFAB	340.7					
"	Lincoln	WFAV	275					
"	Norfolk	WJAG	270					
"	Oak	KFEQ	268					
"	Omaha	KFOX	248					
"	Omaha	KOCH	258					
"	Omaha	WAAW	278					
"	Omaha	WNAL	258					
"	Omaha	WOAW	526					
"	University City	WCAJ	254					
NEW HAMPSHIRE	Chesham	WSAU	229					
"	Hanover	WDCH	256					
"	Laconia	WKAV	224					
NEW JERSEY	Atlantic City	WHAR	275					
"	Atlantic City	WPG	299.8					
"	Camden	WFBI	236					
"	Elizabeth	WIBS	202.6					
"	Gloucester City	WRAX	268					
"	Lambertville	WTAZ	261					
"	Newark	WNJ	252					
"	Newark	WOR	405.2					
"	North Plainfield	WEAM	261					
"	Paterson	WODA	224					
"	Red Bank	WJBI	218.8					
"	Trenton	WOAX	240					
NEW MEXICO	Albuquerque	KFLR	254					
"	Albuquerque	KFVY	256					
"	State College	KFRY	266					
"	State College	KOB	348.6					
NEW YORK	Bay Shore	WRST	215.7					
"	Brooklyn	WFRL	205.4					

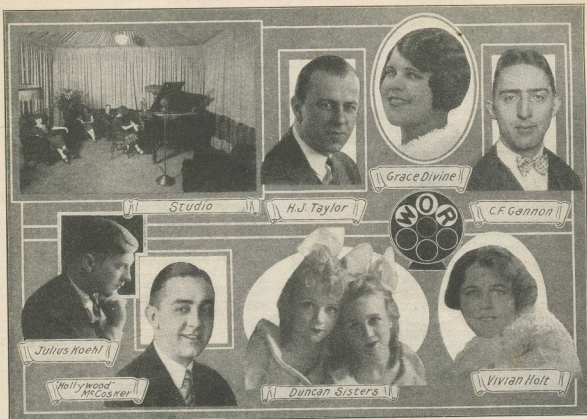

STATES	CITIES	Call Letters	Wave Length (Meters)	Date	Time Received	Dial 1	Dial 2	Dial 3
NEW YORK	Buffalo	WEBR	244					
"	Buffalo	WGR	319					
"	Buffalo	WJBP	218.8					
"	Buffalo	WPDQ	205.4					
"	Canton	WCAD	263					
"	Cazenovia	WMAC	275					
"	Flushing	WIBI	218.8					
"	Freeport	WGBB	244					
"	Ithaca	WEAI	254					
"	Jamestown	WOCL	275					
"	Kingston	WDBZ	233					
"	Lockport	WMAK	266					
"	New York	WBPI	263					
"	New York	WEAF	491.5					
"	New York	WEBJ	273					
"	New York	WFBH	273					
"	New York	WGBS	315.6					
"	New York	WGCP	252					
"	New York	WHAP	240					
"	New York	WHN	361.2					
"	New York	WJY	405.2					
"	New York	WJZ	454.3					
"	New York	WLWL	288.3					
"	New York	WMCA	340.7					
"	New York	WNYC	526					
"	New York	WOKO	233					
"	New York	WQAO	360					
"	New York	WRNY	258					
"	New York	WSDA	263					
"	Richmond Hill	WAHG	315.6					
"	Richmond Hill	WBOQ	236					
"	Richmond Hill	WGMU	236					
"	Richmond Hill	WRMU	236					
"	Richmond Hill	WWGL	212.6					
"	Rochester	WABO	278					
"	Rochester	WHAM	278					
"	Rochester	WHEC	258					
"	Rochester	WBBR	273					
"	Rossville	WGY	379.5					
"	Schenectady	WFBH	252					
"	Syracuse	WRW	273					
"	Tarrytown	WRW	273					
"	Troy	WHAZ	379.5					
"	Utica	WIBX	205.4					
NORTH CAROLINA	Asheville	WABC	254					
"	Charlotte	WBT	275					
"	Charlotte	WJBG	224					
"	Henderson	WIBV	263					
"	Raleigh	WRCO	252					
NORTH DAKOTA	Agricultural College	WPAK	275					
"	Bismark	KFYR	248					
"	Devils Lake	KDLR	231					
"	Fargo	WDAY	261					
"	Grand Forks	KFJM	278					
OHIO	Akron	WADC	258					
"	Bellefontaine	WBBD	222					
"	Cambridge	WEBE	234					
"	Canton	WHBC	254					

STATES	CITIES	Call Letters	Wave Length (Meters)	Date	Time Received	Dial 1	Dial 2	Dial 3
OHIO	Cincinnati	WAAD	258					
"	Cincinnati	WHAG	233					
"	Cincinnati	WHBR	215.7					
"	Cincinnati	WKRC	325.9 422.3					
"	Cincinnati	WLW	422.3					
"	Cincinnati	WSAI	325.9					
"	Cleveland	KDPM	250					
"	Cleveland	WDBK	227					
"	Cleveland	WEAR	389.4					
"	Cleveland	WHK	273					
"	Cleveland	WTAM	389.4					
"	Columbus	WAIU	293.9					
"	Columbus	WCAH	266					
"	Columbus	WEAO	293.9					
"	Columbus	WMAN	278					
"	Dayton	WEB1	256					
"	Dayton	WSME	275					
"	Granville	WJD	217.3					
"	Hamilton	WRK	270					
"	Hamilton	WSRO	252					
"	Lima	WOAC	261					
"	Pomeroy	WSAZ	244					
"	Springfield	WCOS	248					
"	Toledo	WABR	263					
"	Toledo	WIBK	205.4					
"	Toledo	WTAL	252					
"	Wooster	WABW	206.8					
"	Yellow Springs	WRAV	263					
OKLAHOMA	Bristow	KVOO	374.8					
"	Chickasha	KOCW	252					
"	Fort Sill	KFRM	242					
"	Norman	WNAD	254					
"	Oklahoma	KFJF	261					
"	Oklahoma	WKY	275					
"	Tulsa	WLAL	250					
OREGON	Astoria	KFJI	246					
"	Corvallis	KFDJ	282.8					
"	Portland	KFEC	248					
"	Portland	KFIP	248					
"	Portland	KFJR	263					
"	Portland	KFWV	212.6					
"	Portland	KGW	491.5					
"	Portland	KQP	212.6					
"	Portland	KTBR	263					
PENNSYLVANIA	Allentown	WCBA	254					
"	Allentown	WSAN	229					
"	Altoona	WFBG	278					
"	Elkins Park	WIBG	222					
"	Grove City	WSAJ	229					
"	Harrisburg	WABB	266					
"	Harrisburg	WBAK	275					
"	Harrisburg	WHBG	231					
"	Harrisburg	WPRC	215.7					
"	Haverford	WABQ	261					
"	Johnstown	WGBK	248					
"	Johnstown	WHBP	256					

STATES	CITIES	Call Letters	Wave Length (Meters)	Date	Time Received	Dial 1	Dial 2	Dial 3
PENNSYLVANIA	Johnstown	WTAC	268					
"	Lancaster	WDBC	258					
"	Lancaster	WGAL	248					
"	Lewisburg	WJBQ	211.1					
"	Oil City	WHBA	250					
"	Parkersburg	WQAA	220					
"	Philadelphia	WABY	242					
"	Philadelphia	WCAU	278					
"	Philadelphia	WFBD	234					
"	Philadelphia	WFI	394.5					
"	Philadelphia	WHBW	215.7					
"	Philadelphia	WIAD	250					
"	Philadelphia	WIP	508.2					
"	Philadelphia	WLIT	394.5					
"	Philadelphia	WNAT	250					
"	Philadelphia	WOO	508.2					
"	Philadelphia	WWAD	250					
"	Pittsburgh	KDKA	309.1					
"	Pittsburgh	KQV	275					
"	Pittsburgh	WCAE	461.3					
"	Pittsburgh	WJAS	275					
"	Reading	WRAW	238					
"	Scranton	WGBI	240					
"	Scranton	WQAN	250					
"	State College	WPSC	261					
"	Wilkes-Barre	WBAX	256					
"	Wilkes-Barre	WBRE	231					
RHODE ISLAND	Cranston	WDWF	440.9					
"	E. Providence	WKAD	240					
"	Providence	WCBR	205.4					
"	Providence	WCWS	209.7					
"	Providence	WEAN	270					
"	Providence	WGBM	234					
"	Providence	WJAR	305.9					
SOUTH CAROLINA	Charleston	WBBY	268					
"	Greenville	WGBT	236					
SOUTH DAKOTA	Brookings	KFDY	273					
"	Rapid City	WCAT	240					
"	Vermillion	KUSD	278					
"	Yankton	WNAX	244					
TENNESSEE	Chattanooga	WDOD	256					
"	Knoxville	WFEC	250					
"	Knoxville	WNOX	268					
"	Lawrenceburg	WOAN	282.8					
"	Memphis	WGBC	278					
"	Memphis	WHBQ	233					
"	Memphis	WMC	499.7					
"	Nashville	WCBQ	256					
"	Nashville	WDAD	226					
"	Nashville	WSM	282.8					
TEXAS	Amarillo	WDAG	263					
"	Austin	KUT	231					
"	Beaumont	KFDM	315.6					
"	Beaumont	KFXM	227					
"	Beeville	KFRB	248					
"	Brownsville	KFWP	214.2					

Arthur Richter

New Science Building

H.F. Wareing

Marion Henke

Harmony Queens Orchestra

Rev. Father J.B. Kremer

Leo Fitzpatrick

Edith G. Bailey

Transmitter

Deora L. Wolfe

C. Gaylord Hall

Speech Input Equipment

H.C. Campbell

Transmitting Building

STATES	CITIES	Call Letters	Wave Length (Meters)	Date	Time Received	Dial 1	Dial 2	Dial 3
TEXAS	Brownsville	KWWG	278					
"	College Station	WTAW	270					
"	Dallas	WFAA	475.9					
"	Dallas	WRR	246					
"	Dublin	KFPL	252					
"	El Paso	KFXH	242					
"	Fort Worth	KFJZ	254					
"	Fort Worth	KFQB	263					
"	Fort Worth	WBAP	475.9					
"	Galveston	KFLX	240					
"	Galveston	KFUL	258					
"	Greenville	KFPM	242					
"	Houston	KFVI	240					
"	Houston	KFYJ	238					
"	Houston	KPRC	296.9					
"	Houston	WEAY	270					
"	San Antonio	WCAR	263					
"	San Antonio	WOAI	394.5					
"	San Benito	KFLU	236					
"	Waco	WJAD	352.7					
UTAH	Logan	KFXD	205.4					
"	Ogden	KFUR	224					
"	Ogden	KFWA	261					
"	Salt Lake City	KDYL	246					
"	Salt Lake City	KFOO	236					
"	Salt Lake City	KFUT	261					
"	Salt Lake City	KSL	299.8					
U. S.	Portable	WEBL	226					
"	Portable	WEBM	226					
VERMONT	Burlington	WCAX	250					
"	Springfield	WQAE	246					
VIRGINIA	Arlington	NAA	434.5					
"	Norfolk	WBBW	222					
"	Norfolk	WTAR	261					
"	Richmond	WBBL	229					
"	Richmond	WRVA	256					
"	Roanoke	WDBJ	229					
WASHINGTON	Everett	KFBL	224					
"	Lacey	KGY	246					
"	North Bend	KFQW	215.7					
"	Olympia	KFRW	218.8					
"	Pullman	KWSC	348.6					
"	Seattle	KFOA	454.3					
"	Seattle	KJR	384.4					
"	Seattle	KTCL	305.9					
"	Seattle	KTW	454.3					
"	Spokane	KFPY	266					
"	Spokane	KHQ	273					
"	Tacoma	KFBG	250					
"	Tacoma	KGB	250					
"	Tacoma	KMO	250					
"	Walla Walla	KFCF	256					
"	Yakima	KFIQ	256					
WEST VIRGINIA	Weirton	WIBR	246					
WISCONSIN	Beloit	WEBW	268					
"	Camp Lake	WCLO	231					

STATES	CITIES	Call Letters	Wave Length (Meters)	Date	Time Received	Dial 1	Dial 2	Dial 3
WISCONSIN	Fondulac	KFIZ	273					
"	Madison	WHA	535.4					
"	Madison	WIBA	236					
"	Marshfield	WGBR	229					
"	Menomonie	WGBQ	234					
"	Milwaukee	WHAD	275					
"	Milwaukee	WKAF	261					
"	Milwaukee	WSOE	246					
"	Osseo	WTAQ	254					
"	Poynette	WIBU	222					
"	Stevens Point	WLBL	278					
"	Superior	WEBC	242					
"	West De Pere	WHBY	250					
WYOMING	Laramie	KFBU	270					

Additions, changes and eliminations in foregoing list of United States Broadcast Stations given on page 176.



Ina Rains

Dr. L.H. Chernoff

Iris R. Pavey

F. H. Talbot

Antenna & Towers

Capt. A. Thomas Jr.

KOA Orchestra

Slogans of Broadcast Stations in U. S. and Canada

- KDKA—PITTSBURGH, PA.**
The Pioneer Broadcasting Station of the World.
- KDYI—SALT LAKE CITY, UTAH.**
Out on the Great Divide.
- KFAB—LINCOLN, NEBRASKA.**
The Home Sweet Home Station.
- KFAU—BOISE, IDAHO.**
Intermountain Station.
- KFCB—PHOENIX, ARIZ.**
When It's Wintertime in Michigan, It's Summer Time Down Here.
- KFCF—WALLA WALLA, WASH.**
The Valley They Liked so well They Named It Twice.
- KFDM—BEAUMONT, TEXAS.**
Call for Dependable Magnolene.
- KFEY—KELLOG, IDAHO.**
Voice of the Coeur D'Alene.
- KFFP—MOBERLY, MO.**
The Gospel Messenger of the Air.
- KFGQ—BOONE, IOWA.**
Daniel Boone Station.
- KFHA—GUNNISON, COLO.**
Where the Sun Shines Every Day.
- KFI—LOS ANGELES, CALIF.**
The Radio Central Super-Station. (A National Institution.)
- KFJB—MARSHALLTOWN, IOWA.**
Marshalltown The Heart of Iowa.
- KFJF—OKLAHOMA CITY, OKLA.**
Radio Headquarters.
- KFJM—GRAND FORKS, N. D.**
Grand Forks, the Educational Center of the State.
- KFKU—LAWRENCE, KANS.**
Up at Lawrence on the Kaw.
- KFKX—HASTINGS, NEBR.**
The Empress of the Air The Pioneer Re-Broadcasting Station of the World.
- KFLU—SAN BENITO, TEXAS.**
Heart of the Magic Valley.
- KFNF—SHENANDOAH, IOWA.**
Friendly Station in a Friendly Town.
- KFOA—SEATTLE, WASH.**
The Gateway to the Orient. (Pacific Northwest Station.)
- KFON—LONG BEACH, CALIF.**
Where Your Ship Comes In.
- KFOR—DAVID CITY, NEBR.**
The Voice of David City.
- KFPM—GREENVILLE, TEXAS.**
The New Furniture Co. (Biggest Little 10 Watts on the Air.)
- KFPW—CARTERSVILLE, MO.**
Keeping Pace With Christ Means Progress.
- KFQW—NORTH BEND, WASH.**
At the Western Entrance of Snoqualmie Pass.
- KFRW—OLYMPIA, WASH.**
Make the World a Brotherhood.
- KFUJ—BRECKENRIDGE, MINN.**
Where the Red River of the North Finds Its Source.
- KFUM—COLORADO SPRINGS, COLO.**
Known for Unsurpassed Mountain Scenery.
- KFUS—OAKLAND, CALIF.**
The City of Opportunity.
- KFUU—SAN LEANDRO, CALIF.**
The Voice of Automobile Row. (Voice of the Cherry City.)
- KFVE—ST. LOUIS, MO.**
You Will Always Know KFVE by the Tick of Her Clock.
- KFVH—MANHATTAN, KANS.**
Kansas Fans Very Happy.
- KFVN—WELCOME, MINN.**
The Voice of Martin County.
- KFVU—EUREKA, CALIF.**
On the Redwood Highway. (Eureka on the Redwood Highway, the End of the West.)
- KFWA—OGDEN, UTAH.**
Keeping Friends With All.
- KFWH—CHICO, CALIF.**
Kind Friends We're Here.
- KFWO—AVALON, CATALINA ISLAND, CALIF.**
Catalina for Wonderful Outings.

Here's Work That is Almost ROMANCE!



Many EARN \$50. to \$250. a Week in RADIO

Get into the great new BIG-Pay Industry—Radio. If you're earning a penny less than \$50 a week, stop coupon now. Send for AMAZING FREE BOOK. Be a Radio Expert, and draw down big money for the easiest and most fascinating work in the world. Positions everywhere. Need for Radio Experts in every community. Start hours. BIG PAY. Free book gives all the facts.

Learn Quickly and Easily At Home—Master Radio Engineers will show you how to qualify, quickly and easily at home, for Radio's fine jobs. We guarantee to train you successfully. Every day N. R. I.—trained men are taking good places in the Radio field. Thousands of openings now awaiting the trained men. **FREE EMPLOYMENT SERVICE.** Many exciting features. Get the facts—CLIP COUPON.



"My chance for remuneration \$2.00 per hour. All success due to you."
J. W. Mitchell, Brooklyn



"Radio a job mine—my source worth thousands."
A. H. Herbe, Winnetter

Get This Free Book!
Send coupon below for FREE BOOK—"Rich Rewards in Radio." Best for yourself. No previous experience needed. Complete schooling secure. WRITE NOW.



You get all these sets

Receiving sets, from simplest kind to thousand mile receiver, included to help you. An UNQUALIFIED OFFER. Other special features for limited time only, so Act Quick!

NATIONAL RADIO INSTITUTE

Dept. CW6, Washington, D. C.

MAIL COUPON

National Radio Institute,
Dept. CW6, Washington, D. C.

Without obligating me in any way, please send me your free book, "Rich Rewards in Radio," also complete information on your practical, home-study Radio course.

Name Apt.

Address

Town State



John Church
WRC



E.S. Mittendorf
WRC

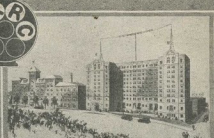

The New Home of
WKRC

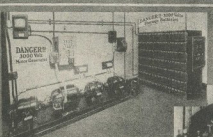

Batteries & Generator
WDBC



Control Room
WSBC



The Studio
WSBC



One of the Studios



G. McNamee



Phillips Carlin



James Haupt



G. Chatfield



Betty Lutz



Reception Room

SLOGANS OF BROADCAST STATIONS IN UNITED STATES AND CANADA (Continued)

- KFXB—BIG BEAR LAKE, CALIF.**
Run of World Super Station.
- KFXF—COLORADO SPRINGS, COLO.**
The Pikes Peak Station.
- KFXH—EL PASO, TEXAS.**
The Voice of the Rio Grande.
- KGB—TACOMA, WASH.**
This is KGB in Tacoma, Wash., the Lumber Capital of America and the Gateway to Mount Tacoma. (The Lumber Capital of the World.)
- KGW—PORTLAND, OREG.**
KGW Keep Growing Wiser.
- KGY—LACEY, WASH.**
Out Where the Cedars Meet the Sea.
- KHJ—LOS ANGELES, CALIF.**
Kindness, Happiness, and Joy.
- KJBS—SAN FRANCISCO, CALIF.**
Royal Order Smoked Herring. (Kleen Jokes, Better Songs.)
- KJR—SEATTLE, WASH.**
Radio Headquarters.
- KMOX—ST. LOUIS, MO.**
Voice of St. Louis.
- KPO—SAN FRANCISCO, CALIF.**
The City by the Golden Gate.
- KPRC—HOUSTON, TEXAS.**
Katton Port Rail Center (Post).
- KQP—PORTLAND, OREG.**
Hood River Apples from Portland, Oreg.
- KTCL—SEATTLE, WASH.**
Know the Charmed Land.
- KTHS—HOT SPRINGS, ARK.**
Kum to Hot Springs.
- KTW—SEATTLE, WASH.**
Hear Ye, Hear Ye, Hear Ye, the Gospel.
- KUO—SAN FRANCISCO, CALIF.**
The Voice of the West.
- KUSD—VERMILLION, S. DAK.**
South Dakota University for South Dakotans.
- KWG—STOCKTON, CALIF.**
Voice of the San Joaquin Valley.
- KWKC—KANSAS CITY, MO.**
Keep Watching Kansas City.
- KWWG—BROWNSVILLE, TEXAS.**
Kum to the World's Winter Garden.
- KZRQ—MANILA, P. I.**
Radio Manila.
- WAAW—OMAHA, NEBR.**
Where Agriculture Accumulates Wealth.
- WABY—PHILADELPHIA, PA.**
Quaker City Sleep Dodgers.
- WABZ—NEW ORLEANS, LA.**
The Station with a Message.
- WAFD—PORT HURON, MICH.**
Gateway to the Great Lakes. (We Are Ford Dealers.)
- WAHG—RICHMOND HILL, N. Y.**
Wait and Hear Grebe.
- WAMD—MINNEAPOLIS, MINN.**
The Voice of the Great Northwest.
- WBAV—COLUMBUS, OHIO.**
We Broadcast a Variety.
- WBAX—WILKES BARRE, PA.**
In Wyoming Valley, Home of the Anthracite.
- WBBM—CHICAGO, ILL.**
World's Best Broadcasting Medium.
- WBBS—NEW ORLEANS, LA.**
The Gospel Waxe.
- WBBW—NORFOLK, VA.**
The School You'd Like to Go to.
- WBCN—CHICAGO, ILL.**
World's Best Community Newspaper.
- WCAC—MANSFIELD, CONN.**
From the Nutmeg State.
- WCAD—CANTON, N. Y.**
The Voice of the North Country.
- WCAL—NORTHFIELD, MINN.**
The College on the Hill.
- WCAO—BALTIMORE, MD.**
The People's Store.
- WCAR—SAN ANTONIO, TEXAS.**
Royal Order of Prevaricators.
- WCAX—BURLINGTON, VT.**
The Voice of the Green Mountains.
- WCBD—ZION, ILL.**
Where God Rules. (Where God Rules Man Prospers.)
- WCBE—NEW ORLEANS, LA.**
Second Port in U. S. A. (Strongest 5 Watt Station in the World.)
- WCCO—ST. PAUL—MINNEAPOLIS, MINN.**
Service to the Northwest.



—as taught in the Great COYNE Shops—

Prepares You for a Big-Pay, Fascinating Steady Job in Radio or Electrical Field!

Electricity and Radio are the fields of Wonderful Opportunities today. They offer BIG PAY, clean, fascinating work and steady employment—anywhere, any time! COYNE TRAINED MEN are in demand because COYNE training is complete and thorough. If you want to know more about Radio, learn all about Electricity—at COYNE. All practical, personal training, on real equipment, in arrest shops.

EARN WHILE YOU LEARN AT COYNE!

My big EMPLOYMENT DEPARTMENT helps you to get a job to earn part or all of your expenses while training and teaches you to a good job on graduation. It stands by you THROUGH LIFE without a penny extra cost to you.



Complete Electrical Training In 12 Happy Weeks at COYNE

My newly-revised Electrical Course is the result of 27 years of experience, adding the needs of young men and of the Electrical Field. My course is absolutely thorough, easy to master, covers every single phase and range of the subject and fits men for Big Electrical jobs. HIGH-SALARIED, thrilling jobs.

YOU DON'T NEED ADVANCED EDUCATION OR EXPERIENCE



Students graduating "artificial lighting" or "X-ray" out in great shops of Commerce. Students operating large switchboards at Coyne

EARN \$60 TO \$200 A WEEK

Big Special Offer If You Act Now! I'll include with my course, without extra charge my big Extra Courses in Radio Electricity and Auto, Truck and Tractor Electricity.



Send Right Away for My Big FREE Book and Special Offer of 2 Big Extra Courses. Be sure to send at once for my big FREE BOOK, containing 125 actual photos of electrical operations and methods; also my special offer of 2 Big Courses without extra cost. Write today before offer is withdrawn.

COYNE ELECTRICAL SCHOOL

H. C. LEWIS, President 1300-10 W. Harrison St., Dept. 1293 Chicago Established 1899

H. C. LEWIS, President
COYNE ELECTRICAL SCHOOL
1300-10 W. Harrison St.
Dept. 1293, Chicago, Illinois

I hear H. C. — You can just bet I want one of those big handsome FREE 1210 books with 125 actual photographs of electrical operations and also access, defined in two colors. Send it quick, before the supply is exhausted. Be sure to tell me all about Special Offer of 2 Big Extra Courses.

Name

Address

SLOGANS OF BROADCAST STATIONS IN UNITED STATES AND CANADA (Continued)

- WCLS—JOLIET, ILL.
Will County's Largest Store.
- WDAD—NASHVILLE, TENN.
The Athens of the South.
- WDAG—AMARILLO, TEXAS.
Where Dollars Always Grow.
- WDAY—FARGO, N. DAK.
The Biggest Little City in the World.
- WDBE—ATLANTA, GA.
We Distribute Better Equipment.
- WDBJ—ROANOKE, VA.
Roanoke Down in Old Virginia.
- WDBO—WINTER PARK, FLA.
Wander Down by Orlando.
- WDOD—CHATTANOOGA, TENN.
Wonderful Dynamo of Dixie.
- WDWF—CRANSTON, R. I.
Quality First.
- WEAF—NEW YORK, N. Y.
The Voice of the Millions.
- WEAM—PLAINFIELD, N. J.
America's Pioneer Municipal Broadcasting Station.
- WEAR—CLEVELAND, OHIO.
Goodyear Tires WEAR.
- WEAU—SIOUX CITY, IOWA.
The Heart of the Corn Belt.
- WEBA—HIGHLAND PARK, N. J.
Wonderful Evenings by Air WEBA.
- WEBH—CHICAGO, ILL.
The Voice of the Great Lakes.
- WEBK—GRAND RAPIDS, MICH.
The Furniture Capital of America.
- WEBQ—HARRISBURG, ILL.
Bluebird Station.
- WEBR—BUFFALO, N. Y.
We Extend Buffalo's Regards.
- WEBT—DAYTON, OHIO.
Worthy Effort Brings Triumph.
- WSM—NASHVILLE, TENN.
We Shield Millions.
- WSMK—DAYTON, OHIO.
The Home of Aviation.
- WSOE—MILWAUKEE, WISC.
In the Land of Sky-blue Waters.
- WSRO—HAMILTON, OHIO.
We Sell Radio Only.
- WTAG—WORCESTER, MASS.
The Voice from the Heart of the Commonwealth.
- WTAM—CLEVELAND, OHIO.
The Voice from the Storage Battery.
- WTAR—NORFOLK, VA.
Down in Old Virginia.
- WTAW—COLLEGE STATION, TEX.
The Voice of the Wilderness.
- WTAX—STREATOR, ILL.
Tappa Kappa Nails.
- WTIC—HARTFORD, CONN.
The Insurance City.
- CFCH—IROQUOIS FALLS, ONT.
The Call of the North.
- CFCN—CALGARY, ALBERTA.
Voice of the Prairies.
- CFCT—VICTORIA, B. C.
The Mecca of Tourists.
- CFQC—SASKATOON, SASK.
The Hub City of the West Where No. 1 Northern Hard Wheat Grows.
- CFXC—NEW WESTMINSTER, B. C.
Voice of the Fraser River.
- CFYC—BURNABY, B. C.
Canada's Flourishing Young City.
- CHCM—CALGARY, ALBERTA.
Western Canada's Leading Leather Goods Store.
- CJCA—EDMONTON, ALBERTA.
The Sunniest Spot in Sunny Alberta.
- CKCD—VANCOUVER, B. C.
Canada's Western Gateway.
- CKCO—OTTAWA, ONT.
Ottawa's Radio Voice. The Community Voice of Canada's Capital.
- CKOC—HAMILTON, ONT.
In the Garden of Canada.
- CKY—WINNIPEG, MAN.
Manitoba's Own Station.
- CNRA—MONCTON, N. B.
Voice of the Maritimes.



OLD TUBES MADE GOOD AS NEW

This latest Laboratory product will recalculate any old, run-down, even worthless tubes, as long as the filament still lights. Makes them good as new in few minutes time. Costs but few cents more than new tubes! Simple, efficient, practical. Big money-saver. Thousands in use. Operates on either A.C. or D.C.—110-220 Volts. Model No. 20 for TV201A (50B1A, etc.) and all similar types. Model No. 20 for TV100 (2200, etc.) and all similar types. Housed to do the work on our

MONEY-BACK GUARANTEE
You cannot lose! Act quick on this special introductory price. Rent Postpaid with full directions on receipt of \$2.85. No more to state Model Number wanted. Our guarantee refund price protects you. Send tube.

MACK LABORATORIES

702 Cass St.

Chicago, Ill.

MACK RECONDITIONER
"THE CURE FOR RUN-DOWN TUBES"

FREE BLUE PRINTS

To Set Builders

TO PROVE THE SELECTIVE AND SENSITIVE COMBINATIONS OBTAINABLE WITH

Werner Transformers

(Radio Frequency Type)

which cover the entire broadcasting wave range and have been used by the best radio engineers for the past 2 years, we will furnish a full size Blue Print of a selective 6 tube Loop Receiver FREE if you order from us direct.

Werner Radio Frequency and Audio Frequency Transformers are fully guaranteed and tested, on actual broadcast reproduction. Guaranteed silent and moisture proof and will give perfect reception in any climate.

MADE IN TWO TYPES

Tuned and retuned for any standard type vacuum tube Radio Frequency \$4. Audio Frequency \$6.

Werner Loop Antenna

Used with any type of loop receiver. Adjustable to a fine degree of impedance. Can be folded or extended without tools. Approved by POPULAR RADIO.

PRICE POSTPAID \$14.00

Send for free circuit diagrams and descriptive literature

Book of Slip-on-disc, portable R. F. circuit diagrams and treatise on R. F. amplification postpaid 25c

Ask Your Radio Dealer

WERNER MFG. COMPANY

204 Ninth St. Brooklyn, N. Y.

Ragemco

RADIO HEADQUARTERS FOR
THE BEST AND CHEAPEST
RADIO TOOLS

Send Postal Card for Our
Illustrated Catalog — FREE

The Radiogem Corp.

66 W. Broadway, New York

Kilocycle-Meter Conversion Table

The Department of Commerce specifies radio station assignments in both kilocycles and meters. The tendency of radio engineering practice is to use and express frequency in kilocycles rather than wave length in meters. "Kilo" means a thousand, and "cycle" means one complete alternation. The number of kilocycles indicates the number of thousands of times that the rapidly alternating current in the antenna repeats its flow in either direction in one second. The smaller the wave length in meters, the larger is the frequency in kilocycles. The numerical

relation between the two is very simple. For approximate calculation, to obtain kilocycles, divide 300,000 by the number of meters; to obtain meters divide 300,000 by the number of kilocycles. For example, 100 meters equals approximately 3000 kilocycles, 300 m equals 1000 kc, 1000 m equals 300 kc, 3000 m equals 100 kc.

For highly accurate conversion the factor 299,820 should be used instead of 300,000. The table below gives accurate values of kilocycles corresponding to any number of meters and vice versa. The table is based on the fac-

tor 299,820, and gives values for every 10 kilocycles or meters. It should be particularly noticed that the table is entirely reversible; that is, for example, 50 kilocycles is 5996 meters, and also 50 meters is 5996 kilocycles. The range of the table is easily extended by shifting the decimal point; for example, one can not find 223 in the first column, but its equivalent is obtained by finding later in the table that 2230 kilocycles or meters is equivalent to 134.4 meters or kilocycles, from which 223 kilocycles or meters is equivalent to 1344 meters or kilocycles.

KILOCYCLES TO METERS, OR METERS TO KILOCYCLES

Meters	Kilocycles	Meters	Kilocycles	Meters	Kilocycles	Meters	Kilocycles	Meters	Kilocycles	Meters	Kilocycles	Meters	Kilocycles
10	29980	720	416.4	1430	209.7	2140	140.1	2850	105.2	4120	72.77	6400	46.85
20	14990	730	410.7	1440	208.2	2150	139.5	2860	104.8	4140	72.42	6430	46.48
30	9994	740	405.2	1450	206.8	2160	138.9	2870	104.5	4160	72.07	6460	46.13
40	7496	750	399.8	1460	205.4	2170	138.1	2880	104.1	4180	71.73	6500	45.77
50	5996	760	394.5	1470	204.0	2180	137.5	2890	103.7	4200	71.39	6540	45.43
60	4997	770	389.2	1480	202.7	2190	136.9	2900	103.3	4220	71.05	6580	45.09
70	4253	780	384.4	1490	201.2	2200	136.3	2910	103.0	4240	70.71	6620	44.75
80	3748	790	379.5	1500	199.9	2210	135.7	2920	102.7	4260	70.38	6750	44.42
90	3311	800	374.8	1510	198.6	2220	135.1	2930	102.3	4280	70.05	6800	55.09
200	2998	810	370.2	1520	197.3	2230	134.5	2940	102.0	4300	69.72	6850	43.77
110	2726	820	365.6	1530	196.0	2240	133.8	2950	101.6	4320	69.40	6900	43.45
120	2499	830	361.2	1540	194.7	2250	133.3	2960	101.3	4340	69.08	6950	43.14
130	2306	840	356.9	1550	193.4	2260	132.7	2970	101.0	4360	68.76	7000	42.83
140	2142	850	352.7	1560	192.2	2270	132.1	2980	100.6	4380	68.45	7050	42.53
150	1999	860	348.6	1570	191.0	2280	131.5	2990	100.3	4400	68.14	7100	42.23
160	1874	870	344.6	1580	189.8	2290	131.0	3000	99.94	4420	67.83	7150	41.93
170	1764	880	340.7	1590	188.6	2300	130.4	3020	99.28	4440	67.53	7200	41.64
180	1666	890	336.9	1600	187.4	2310	129.8	3040	98.62	4460	67.22	7250	41.35
190	1578	900	333.1	1610	186.2	2320	129.2	3060	97.98	4480	66.91	7300	41.07
200	1499	910	329.5	1620	185.1	2330	128.7	3080	97.34	4500	66.63	7350	40.79
210	1428	920	325.9	1630	183.9	2340	128.1	3100	96.72	4520	66.33	7400	40.52
220	1363	930	322.4	1640	182.8	2350	127.6	3120	96.10	4540	66.04	7450	40.24
230	1304	940	319.0	1650	181.7	2360	127.0	3140	95.48	4560	65.75	7500	39.98
240	1249	950	315.6	1660	180.6	2370	126.5	3160	94.88	4580	65.46	7550	39.73
250	1199	960	312.3	1670	179.5	2380	126.0	3180	94.28	4600	65.18	7600	39.45
260	1153	970	309.1	1680	178.5	2390	125.4	3200	93.69	4620	64.90	7650	39.19
270	1110	980	305.9	1690	177.4	2400	124.9	3220	93.11	4640	64.62	7700	38.94
280	1071	990	302.8	1700	176.4	2410	124.4	3240	92.54	4660	64.34	7750	38.69
290	1034	1000	299.8	1710	175.3	2420	123.9	3260	91.97	4680	64.06	7800	38.44
300	999.4	1010	296.9	1720	174.3	2430	123.4	3280	91.41	4700	63.79	7850	38.19
310	967.2	1020	293.9	1730	173.3	2440	122.9	3300	90.86	4720	63.52	7900	37.95
320	936.9	1030	291.1	1740	172.3	2450	122.4	3320	90.31	4740	63.25	7950	37.71
330	908.4	1040	288.3	1750	171.3	2460	121.9	3340	89.77	4760	62.99	8000	37.48
340	881.8	1050	285.5	1760	170.4	2470	121.4	3360	89.23	4780	62.73	8050	37.25
350	856.6	1060	282.8	1770	169.4	2480	120.9	3380	88.70	4800	62.46	8100	37.02
360	832.8	1070	280.2	1780	168.4	2490	120.4	3400	88.18	4820	62.20	8150	36.79
370	810.3	1080	277.6	1790	167.5	2500	119.9	3420	87.67	4840	61.94	8200	36.57
380	789.0	1090	275.1	1800	166.6	2510	119.3	3440	87.16	4860	61.69	8250	36.34
390	768.8	1100	272.6	1810	165.6	2520	118.8	3460	86.65	4880	61.44	8300	36.12
400	749.6	1110	270.1	1820	164.7	2530	118.4	3480	86.15	4900	61.19	8350	35.91
410	731.3	1120	267.7	1830	163.8	2540	118.0	3500	85.66	4920	60.94	8400	35.70
420	713.9	1130	265.3	1840	162.9	2550	117.6	3520	85.18	4940	60.69	8450	35.48
430	697.7	1140	263.0	1850	162.0	2560	117.1	3540	84.70	4960	60.45	8500	35.27
440	681.4	1150	260.7	1860	161.2	2570	116.7	3560	84.22	4980	60.20	8550	35.07
450	666.3	1160	258.5	1870	160.3	2580	116.2	3580	83.75	5000	59.96	8600	34.86
460	651.8	1170	256.3	1880	159.5	2590	115.8	3600	83.28	5020	59.71	8650	34.66
470	637.9	1180	254.1	1890	158.6	2600	115.3	3620	82.82	5040	59.46	8700	34.46
480	624.6	1190	252.0	1900	157.8	2610	114.9	3640	82.37	5150	59.22	8750	34.26
490	611.9	1200	249.9	1910	157.0	2620	114.4	3660	81.92	5200	58.97	8800	34.07
500	599.6	1210	247.8	1920	156.2	2630	114.0	3680	81.47	5250	58.72	8850	33.88
510	587.9	1220	245.8	1930	155.3	2640	113.6	3700	81.03	5300	58.47	8900	33.69
520	576.6	1230	243.8	1940	154.5	2650	113.1	3720	80.59	5350	58.22	8950	33.50
530	565.7	1240	241.8	1950	153.8	2660	112.7	3740	80.17	5400	57.97	9000	33.31
540	555.2	1250	239.9	1960	153.0	2670	112.3	3760	79.74	5450	57.72	9050	33.12
550	545.1	1260	238.0	1970	152.2	2680	111.9	3780	79.32	5500	57.47	9100	32.93
560	535.5	1270	236.1	1980	151.4	2690	111.5	3800	78.90	5550	57.22	9150	32.74
570	526.0	1280	234.2	1990	150.7	2700	111.0	3820	78.49	5600	56.97	9200	32.55
580	516.9	1290	232.4	2000	149.9	2710	110.6	3840	78.08	5650	56.72	9250	32.34
590	508.2	1300	230.6	2010	149.2	2720	110.2	3860	77.67	5700	56.47	9300	32.14
600	499.7	1310	228.9	2020	148.4	2730	109.8	3880	77.27	5750	56.22	9350	31.94
610	491.3	1320	227.1	2030	147.7	2740	109.4	3900	76.88	5800	55.97	9400	31.74
620	483.6	1330	225.4	2040	147.0	2750	109.0	3920	76.49	5850	55.72	9450	31.53
630	475.9	1340	223.7	2050	146.3	2760	108.6	3940	76.10	5900	55.47	9500	31.33
640	468.5	1350	222.1	2060	145.6	2770	108.2	3960	75.71	5950	55.22	9550	31.12
650	461.3	1360	220.4	2070	144.8	2780	107.8	3980	75.33	6000	49.97	9600	31.26
660	454.3	1370	218.8	2080	144.1	2790	107.5	4000	74.96	6050	49.56	9650	31.07
670	447.5	1380	217.2	2090	143.5	2800	107.1	4020	74.58	6100	49.15	9700	30.87
680	440.9	1390	215.7	2100	142.3	2810	106.7	4040	74.21	6150	48.75	9750	30.70
690	434.4	1400	214.2	2110	141.1	2820	106.3	4060	73.85	6200	48.36	9800	30.59
700	428.1	1410	212.6	2120	140.1	2830	105.9	4080	73.49	6250	47.97	9850	30.44
710	422.3	1420	211.1	2130	140.8	2840	105.6	4100	73.13	6300	47.59	9900	30.31
										6350	47.22	9950	30.16

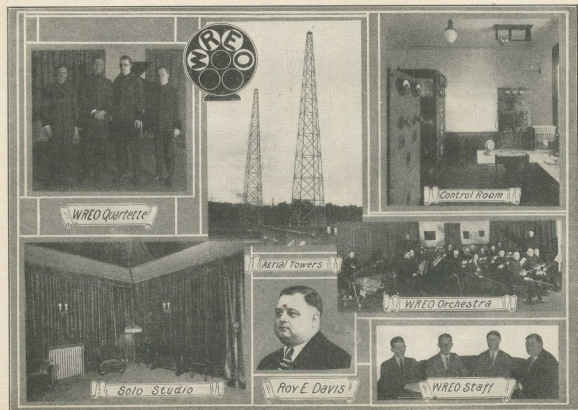
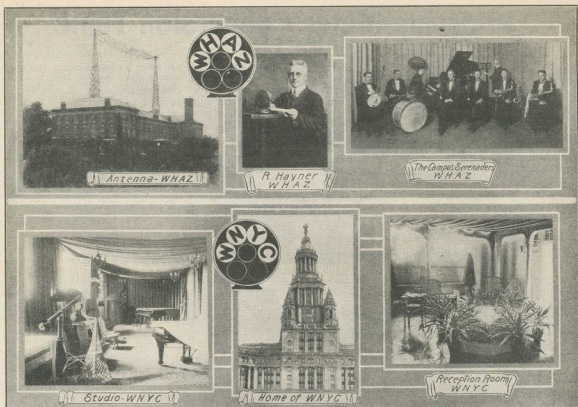

Studio
KSAC

S. Pickard
KSAC

Antenna
KSAC

Transmitter
WEEI

Bob Emery
WEEI

Mr. Myers
WEEI

Lullaby Boys

Tom Owens

W.B. Amsbery

Handy Andy

Alma Claussen

F.L. Petty

E.L. Bill

AMERICAN RADIO RELAY LEAGUE

This organization was formed in 1910 by Mr. H. P. Maxim, the inventor, and is purely an "amateur" organization in that it exists for the benefit of the art and is not in any way a profit-making organization. The primary purpose of the League is the relaying of messages to all parts of the country. To accomplish this end a traffic department is in existence by which the United States and Canada are divided into a number of divisions as shown, each having a Division Manager in charge. Each state is under the jurisdiction of an Assistant Division Manager who has in turn District Superintendents under him in such number as the population and size of the state warrants. Cities of 25,000 or more have City Managers and smaller cities have official relay stations. By means of this organization it is possible to transmit messages throughout the country without any charge to the sender.

DIRECTORY OFFICERS

President HIRAM PERCY MAXIM Hartford, Conn.	Vice-President CHAS. H. STEWART St. David's, Pa.	Traffic Manager F. H. SCHNELL Hartford, Conn.	Canadian Gen. Manager A. H. K. RUSSELL 6 Mail Bldg., Toronto, Ont.	Treasurer A. A. HEBERT Hartford, Conn.	Secretary K. B. WARNER Hartford, Conn.
DIRECTORS					
President HIRAM PERCY MAXIM Drawer 4, Hartford, Conn.	Vice-President CHAS. H. STEWART St. David's, Pa.	Delta Division BENJ. F. PAINTER 424 Hamilton Nat. Bank Bldg., Chattanooga, Tenn.	Canada A. H. K. RUSSELL 6 Mail Bldg., Toronto, Ont.	Hudson Division DR. LAWRENCE J. DUNN 450 East 12th St., Brooklyn, N. Y.	Atlantic Division DR. EUGENE C. WOODRUFF 245 West Fairmont Ave., State College, Pa.
Central Division CLYDE E. DARR 157 Hill Ave., Highland Park, Detroit, Mich.	Delaware Division C. M. JANSKY, JR. Dept. of Elec. Eng., U. of M., Philadelphia, Pa.	Pacific Division ALLEN H. BABCOCK 65 Market St., San Francisco, Cal.	Florida Division W. TREDWAY GRAWLEY 424 Main St., Dunville, Fla.	Rocky Mountain Division PAUL M. SEGAL Box 134-A, Route 6, Omaha, Neb.	Midwest Division PORTER H. QUINBY Box 134-A, Route 6, Omaha, Neb.
New England Division DR. ELLIOT A. WHITE c/o K. Taylor, N. Park St., Hastore, N. H.	Northeastern Division K. W. WEINGARTEN 3219 No. 24th St., Tacoma, Wash.	West Gulf Division FRANK M. CORLETT 2513 Catherine St., Dallas, Tex.	Rocky Mountain Division PAUL M. SEGAL Box 134-A, Route 6, Omaha, Neb.	Midwest Division PORTER H. QUINBY Box 134-A, Route 6, Omaha, Neb.	Atlantic Division DR. EUGENE C. WOODRUFF 245 West Fairmont Ave., State College, Pa.
Southeastern Division HARRY F. DOBBS c/o DeLoe & Wey Co., Atlanta, Ga.	Southwestern Division HARRY F. DOBBS c/o DeLoe & Wey Co., Atlanta, Ga.	West Gulf Division FRANK M. CORLETT 2513 Catherine St., Dallas, Tex.	Rocky Mountain Division PAUL M. SEGAL Box 134-A, Route 6, Omaha, Neb.	Midwest Division PORTER H. QUINBY Box 134-A, Route 6, Omaha, Neb.	Atlantic Division DR. EUGENE C. WOODRUFF 245 West Fairmont Ave., State College, Pa.

ADVISORY TECHNICAL COMMITTEE

STUART BALLANTINE	FRANK CONRAD	MINTON CRONKHITE	PAUL F. GODLEY	D. G. McDA	R. H. G. MATHEWS
LEO C. YOUNG	WM. C. BALLARD, Jr.	J. H. DELLINGER	F. C. BLAKE	L. A. HAZELTINE	S. KRUSE
LEROY H. E. CLAUSING	GERALD M. BEST	J. H. FARAND	MELVILLE EASTMAN	C. D. TUSKINA	

TRAFFIC DEPARTMENT OF THE AMERICAN RADIO RELAY LEAGUE

ATLANTIC DIVISION		NORTHWESTERN DIVISION (continued)	
Manager, 3DW	E. R. Davall, Box 317, Edmonston, Md.	A.D.M. Oregon, 71W	Paul E. Hoop, P. O. Box 5, Eugene
A.D.M. D. C. 3AB	A. B. Goodall, 1824 Inglewood Ter., Washington	A.D.M. Idaho, 70W	K. S. Norquist, Westport, Boise
A.D.M. Maryland, 8BU	G. L. Dickinson, Jr., Chapel Gate Lane, Ten Hills, Baltimore	A.D.M. Alaska, 7DB	Leo H. Martin, Box 452, Oonah, Alaska
Sec. N. J., 6EH	H. W. Houston, 140 Washington St., Collingwood	PACIFIC DIVISION	
A.D.M. West N. Y., 8PJ	C. S. Taylor, 595 Masten St., Buffalo	Manager, Southern Section, GANL-6LJ	M. E. McCortey, 317 Central Ave., Los Angeles, Ca.
A.D.M. East, Pa., 8FM	J. F. Rex, 2095 E. Kingston St., Philadelphia	A.D.M. Div. 1, 2, 3, 4, 5, 6, 7, 8, 9, 10, 11, 12, 13, 14, 15, 16, 17, 18, 19, 20, 21, 22, 23, 24, 25, 26, 27, 28, 29, 30, 31, 32, 33, 34, 35, 36, 37, 38, 39, 40, 41, 42, 43, 44, 45, 46, 47, 48, 49, 50, 51, 52, 53, 54, 55, 56, 57, 58, 59, 60, 61, 62, 63, 64, 65, 66, 67, 68, 69, 70, 71, 72, 73, 74, 75, 76, 77, 78, 79, 80, 81, 82, 83, 84, 85, 86, 87, 88, 89, 90, 91, 92, 93, 94, 95, 96, 97, 98, 99, 100, 101, 102, 103, 104, 105, 106, 107, 108, 109, 110, 111, 112, 113, 114, 115, 116, 117, 118, 119, 120, 121, 122, 123, 124, 125, 126, 127, 128, 129, 130, 131, 132, 133, 134, 135, 136, 137, 138, 139, 140, 141, 142, 143, 144, 145, 146, 147, 148, 149, 150, 151, 152, 153, 154, 155, 156, 157, 158, 159, 160, 161, 162, 163, 164, 165, 166, 167, 168, 169, 170, 171, 172, 173, 174, 175, 176, 177, 178, 179, 180, 181, 182, 183, 184, 185, 186, 187, 188, 189, 190, 191, 192, 193, 194, 195, 196, 197, 198, 199, 200, 201, 202, 203, 204, 205, 206, 207, 208, 209, 210, 211, 212, 213, 214, 215, 216, 217, 218, 219, 220, 221, 222, 223, 224, 225, 226, 227, 228, 229, 230, 231, 232, 233, 234, 235, 236, 237, 238, 239, 240, 241, 242, 243, 244, 245, 246, 247, 248, 249, 250, 251, 252, 253, 254, 255, 256, 257, 258, 259, 260, 261, 262, 263, 264, 265, 266, 267, 268, 269, 270, 271, 272, 273, 274, 275, 276, 277, 278, 279, 280, 281, 282, 283, 284, 285, 286, 287, 288, 289, 290, 291, 292, 293, 294, 295, 296, 297, 298, 299, 300, 301, 302, 303, 304, 305, 306, 307, 308, 309, 310, 311, 312, 313, 314, 315, 316, 317, 318, 319, 320, 321, 322, 323, 324, 325, 326, 327, 328, 329, 330, 331, 332, 333, 334, 335, 336, 337, 338, 339, 340, 341, 342, 343, 344, 345, 346, 347, 348, 349, 350, 351, 352, 353, 354, 355, 356, 357, 358, 359, 360, 361, 362, 363, 364, 365, 366, 367, 368, 369, 370, 371, 372, 373, 374, 375, 376, 377, 378, 379, 380, 381, 382, 383, 384, 385, 386, 387, 388, 389, 390, 391, 392, 393, 394, 395, 396, 397, 398, 399, 400, 401, 402, 403, 404, 405, 406, 407, 408, 409, 410, 411, 412, 413, 414, 415, 416, 417, 418, 419, 420, 421, 422, 423, 424, 425, 426, 427, 428, 429, 430, 431, 432, 433, 434, 435, 436, 437, 438, 439, 440, 441, 442, 443, 444, 445, 446, 447, 448, 449, 450, 451, 452, 453, 454, 455, 456, 457, 458, 459, 460, 461, 462, 463, 464, 465, 466, 467, 468, 469, 470, 471, 472, 473, 474, 475, 476, 477, 478, 479, 480, 481, 482, 483, 484, 485, 486, 487, 488, 489, 490, 491, 492, 493, 494, 495, 496, 497, 498, 499, 500, 501, 502, 503, 504, 505, 506, 507, 508, 509, 510, 511, 512, 513, 514, 515, 516, 517, 518, 519, 520, 521, 522, 523, 524, 525, 526, 527, 528, 529, 530, 531, 532, 533, 534, 535, 536, 537, 538, 539, 540, 541, 542, 543, 544, 545, 546, 547, 548, 549, 550, 551, 552, 553, 554, 555, 556, 557, 558, 559, 560, 561, 562, 563, 564, 565, 566, 567, 568, 569, 570, 571, 572, 573, 574, 575, 576, 577, 578, 579, 580, 581, 582, 583, 584, 585, 586, 587, 588, 589, 590, 591, 592, 593, 594, 595, 596, 597, 598, 599, 600, 601, 602, 603, 604, 605, 606, 607, 608, 609, 610, 611, 612, 613, 614, 615, 616, 617, 618, 619, 620, 621, 622, 623, 624, 625, 626, 627, 628, 629, 630, 631, 632, 633, 634, 635, 636, 637, 638, 639, 640, 641, 642, 643, 644, 645, 646, 647, 648, 649, 650, 651, 652, 653, 654, 655, 656, 657, 658, 659, 660, 661, 662, 663, 664, 665, 666, 667, 668, 669, 670, 671, 672, 673, 674, 675, 676, 677, 678, 679, 680, 681, 682, 683, 684, 685, 686, 687, 688, 689, 690, 691, 692, 693, 694, 695, 696, 697, 698, 699, 700, 701, 702, 703, 704, 705, 706, 707, 708, 709, 710, 711, 712, 713, 714, 715, 716, 717, 718, 719, 720, 721, 722, 723, 724, 725, 726, 727, 728, 729, 730, 731, 732, 733, 734, 735, 736, 737, 738, 739, 740, 741, 742, 743, 744, 745, 746, 747, 748, 749, 750, 751, 752, 753, 754, 755, 756, 757, 758, 759, 760, 761, 762, 763, 764, 765, 766, 767, 768, 769, 770, 771, 772, 773, 774, 775, 776, 777, 778, 779, 780, 781, 782, 783, 784, 785, 786, 787, 788, 789, 790, 791, 792, 793, 794, 795, 796, 797, 798, 799, 800, 801, 802, 803, 804, 805, 806, 807, 808, 809, 810, 811, 812, 813, 814, 815, 816, 817, 818, 819, 820, 821, 822, 823, 824, 825, 826, 827, 828, 829, 830, 831, 832, 833, 834, 835, 836, 837, 838, 839, 840, 841, 842, 843, 844, 845, 846, 847, 848, 849, 850, 851, 852, 853, 854, 855, 856, 857, 858, 859, 860, 861, 862, 863, 864, 865, 866, 867, 868, 869, 870, 871, 872, 873, 874, 875, 876, 877, 878, 879, 880, 881, 882, 883, 884, 885, 886, 887, 888, 889, 890, 891, 892, 893, 894, 895, 896, 897, 898, 899, 900, 901, 902, 903, 904, 905, 906, 907, 908, 909, 910, 911, 912, 913, 914, 915, 916, 917, 918, 919, 920, 921, 922, 923, 924, 925, 926, 927, 928, 929, 930, 931, 932, 933, 934, 935, 936, 937, 938, 939, 940, 941, 942, 943, 944, 945, 946, 947, 948, 949, 950, 951, 952, 953, 954, 955, 956, 957, 958, 959, 960, 961, 962, 963, 964, 965, 966, 967, 968, 969, 970, 971, 972, 973, 974, 975, 976, 977, 978, 979, 980, 981, 982, 983, 984, 985, 986, 987, 988, 989, 990, 991, 992, 993, 994, 995, 996, 997, 998, 999, 1000	

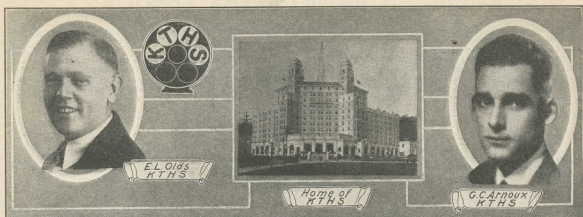

Canadian Radio Broadcast Stations

States and Cities	Owner	Call Letters	Wave Length (Meters)	Power (Watts)	Date	Time Received	Dial 1	Dial 2	Dial 3
NOVA SCOTIA—									
Glace Bay	Marconi	DO	3,000						
Halifax	Marconi	CFCF	440						
"	Radio Engineers	CHAC	400	500					
"	Eastern Telegraph & Telephone Co.	CJCS	410						
NEW BRUNSWICK—									
Moncton	Canadian National Railways	CNRA	313	1,000					
St. John	Jones Electric Co.	CKCR	400						
"	Maritime Radio Corporation	CJCI	400						
QUEBEC—									
Bellevue	Semmelhaack-Dickson (Ltd.)	CFCQ	450	40					
Gouin Dam	Shawaningin Water & Power Co.	DW	1,900						
Iroquois Falls	Abitibi Power & Paper Co.	DS	1,590						
Mont Joli	Dr. J. L. P. Landry	CJCM	312	500					
Montreal	University of Montreal	CFUC	400						
"	A. Contiore	CJCL	270						
"	Northern Electric Co.	CHYC	410	500					
"	Canadian National Railways	CNRM	341	2,000					
"	Bell Telephone Co.	CKCS							
"	La Presse Publishing Co.	CKAC	430	2,000					
"	Depuis Freres	CJBC	420						
"	Marconi	CFCF	440	500					
Quebec	Shawaningin Water & Power Co.	DX	1,900						
"	La Soliel Publishing Co.	CKCI	295	200					
"	La Cie. d'Evenement	CFCJ	410						
Thetford Mines	Shawaningin Water & Power Co.	DY	1,900						
Victoriaville	Shawaningin Water & Power Co.	DV	1,900						
ONTARIO—									
Hamilton	Wilkenson Electric Co. (Ltd.)	CKLC	400						
"	Hamilton Spectator	CHCS	410	2,000					
"	Wentworth Radio Supply Co.	CKOC	410	100					
"	Jack V. Elliott (Ltd.)	CFUC	410						
Iroquois Falls	Abitibi Power & Paper Co.	CFCH	400	500					
Kingston	Queens University	CFRC	450	1,500					
Kitchener	The News Record (Ltd.)	CJCP	295	300					
London	Charles Guy Hunter	CFCL	430	100					
"	Free Press Printing Co.	CJCG	430	200					
"	London Radio Shop	CHCO	410						
"	Radio Supply Co.	CKQC	410						
"	London Radio Co.	CFCW	430	600					
Ottawa	Canadian National Railways	CKCH	435						
"	Canadian National Railways	CNRO	435	500					
"	J. R. Booth, Jr.	CHXC	400	1,200					
"	Dr. G. M. Geldert	CKCO	400	200					
Markham	Marconi	DQ	3,300						
Sudbury	Laurentide Air Service	CFCR	410	200					
Thorold	D. J. Fendell	CFKC	295						
Toronto	Northern Electric Co.	CHIC	350						
"	Simons Agnew & Co.	CJCN	410						
"	Metropolitan Motors	CHVC	410						
"	Marconi	CHCB	440						
"	T. Eaton Co.	CJCD	410	100					

States and Cities	Owner	Call Letters	Wave Length (Meters)	Power (Watts)	Date	Time Received	Dial 1	Dial 2	Dial 3
Toronto	Canadian National Railways (under construction)								
"	Jarvis Street Baptist Church	CJBC	312						
"	Toronto Radio Research Society	CHNC	350	200					
"	Canadian National Railways	CNRT	400	2,000					
"	Bell Telephone Co.	CFTC							
"	Evening Telegram	CJSC	430	500					
"	Star Publishing & Printing Co.	CFCA	400	2,000					
"	Canadian Ind. Tel. Co.	CKCE	450	2,000					
Twin Falls	Abitibi Power & Paper Co.	DT	1,590						
MANITOBA—									
Winnipeg	Manitoba Free Press	CJCG	410						
"	Canadian National Railways	CNRW	450	2,000					
"	Tribune Newspaper Co.	CJNC	400						
"	Manitoba Telephone System	CKY	450	500					
"	Radio Engineering Co.	CKZC	420						
SASKATCHEWAN—									
Regina	Canadian National Railways	CNRR	420	2,000					
"	G. M. Bell and Leader Pub. Co.	CKCK	420	2,000					
Saskatoon	Canadian National Railways	CNRS	400	500					
"	International Bible Students Asso.	CHUC	400						
"	The Electric Shop	CFQC	400	200					
ALBERTA—									
Calgary	Albertan Publishing Co.	CHBC	410	500					
"	Canadian National Railways	CNRC	440	1,600					
"	W. W. Grant Radio (Ltd.)	CFCN	440	1,750					
"	Calgary Herald	CFAC	430	2,000					
"	E. Taylor	CJCY	420						
"	Western Radio Co.	CHCQ	400						
"	G. Melrose Bell	CGAC	430						
"	H. Birks & Sons	CFHC	440	1,000					
"	Riley & McCormick	CHCM	440	1,000					
"	Radio Corporation of Calgary (Ltd.)	CJCK	316	500					
"	P. Burns & Co.	CKCX	440	1,000					
Edmonton	Edmonton Journal	CJCA	450	500					
"	Canadian National Railways	CNRE	450	500					
"	Radio Supply Co.	CFCK	410	250					
Olds	Perceival Wesley Shackleton	CJCX	400						
BRITISH COLUMBIA—									
Lulu Island	Canadian National Railways	CNRV							
Nainamo	Sparks Co.	CFDC	430	50					
Nelson	J. G. Bennett	CJBC	400						
New Westminster	Westminster Trust Co.	CFXC	440						
Ocean Falls	Pacific Mills (Ltd.)	CD	600—1,600						
Vancouver	Canadian Westinghouse Co. (Ltd.)	CHOC	400						
"	Canadian National Railways								
"	First Congregational Church	CKFC	385						
"	Victor W. Odium	CFYC	400	20					
"	Radio Specialties Co.	CFCQ	450	40					
"	Marconi	CFCD	440						
"	Vancouver Merchants Exchange	CNCL	440						
"	Daily Province	CKCD	410	2,000					
"	Sprott Shaw Radio Co.	CJCE	400	150					
Victoria	Western Canada Radio Supply Co.	CHCE	400	20					
"	Centennial Methodist Church	CFCL	400	500					
"	Victoria City Temple	CFCT	410	500					



Foreign Radio Broadcast Stations

Including U. S. Possessions

States and Cities	Owner	Call Letters	Wave Length (Meters)	Power (Watts)	Date	Time Received	Dial 1	Dial 2	Dial 3
ALASKA									
Juneau	Alaska Electric Light & Power Co.	KFIU	226	10					
ALGERIA									
Algiers	Colin & Fils	8DB	180-200	100					
ARGENTINA									
Buenos Aires	Argentine Ass'n of Broadcasters	LOR	350-410	*500					
" "	Radio Nacional	LOY		*1,000					
" "	Francisco J. Brusa	B1							
" "	Falcutad de Ciencias Medicas	C1							
" "	Departamento Nacional de Higiene	C3							
" "	Departamento Nacional de Higiene	C2							
" "	Sociedade Radio Telefonico	A1							
" "	Radio Cultura	LOX	375	*500					
" "	Grand Splendid Theater	LOW		*1,000					
" "	Francisco J. Brusa	LOV		*1,000					
" "	Senores Bocci Hermanos	A11							
Tucuman	Radio Club			*100					
AUSTRALIA									
Adelaide	Central Broadcasting Co.	5CL	395	*5,000					
"	F. J. Hume	5DN	313	*500					
"	Marshall & Co.	5MC	273	*500					
Brisbane	Queensland Government Bureau of Agriculture	4QG	385	*5,000					
Hobart	Associated Radio Co. (projected)	7ZL	390	*3,000					
Melbourne	Associated Radio Co.	3AR	484	*5,000					
"	Broadcasting Co. of Australia	3LO	371	*5,000					
"	Wangaratta Sports Depot	3HW	300	*100					
Mildura	R. J. Egge	3EO	520	*100					
Newcastle	Broadcasters Sydney (Ltd) (proj.)								
"	H. A. Douglas	2HD	333	*50					
Perth	Westralian Farmers (Ltd.)	2WF	1,250	*5,000					
Sydney	Electrical Utilities Supply Co.	2UE	293	*250					
"	Burgin Electric Co.	2BE	316	*100					
"	A. W. A.	2WA	462	*500					
"	Farmer & Co., (Ltd.)	2FO	1,100	*5,000					
"	Labor Party (projected)			*3,000					
"	Broadcastings Sydney (Ltd.)	2BL	353	*1,500					
AUSTRIA									
Bregenz	Projected (relay)								
Graz	Oesterreichischer Radioverkehrs Gesellschaft		404	*500					
Innsbruck	Projected (relay)								
Klagenfurt	Projected (relay)								
Linz	Projected (relay)								
Salzburg	Projected (relay)								
Vienna	Oesterreichischer Radioverkehrs Gesellschaft	ORV	530	2,000					
BELGIUM									
Brussels	Radio Belgique Co.	(¹)	265	1,600					
Haeren		BAV	900-100	4000					
BRAZIL									
Bahia	Cia. Radiotelegraphica Brasiliara (projected)			*500					
"	Radio Sociedade do Bahia		250-450	*500					

(*). Preceding the power of the station indicates that there is doubt as to whether power given is input or antenna measurement.

(¹).—Radio Belgique. When no mark precedes figures in column headed "Power-Watts" the figures indicate antenna measurement.

States and Cities	Owner	Call Letters	Wave Length (Meters)	Power (Watts)	Date	Time Received	Dial 1	Dial 2	Dial 3
FINLAND									
Helsingfors	Civil Guards of Finland								
"	Youth's Society		300	*250					
Skatudden	Military Station	(¹)	420	*1,000					
Tammerfors	Nuoren Voiman Liiton Radioyhdistys	3NB	300	*250					
FRANCE									
Abbeyville			900						
Agen									
Bordeaux	Lafayette Station								
Dijon		FND	900						
Issy-sur-Moulineaux	Ministry of Posts		1,600						
Lille	Coupleux Freres								
Lyon	Ministry of Posts	YN	550	*500					
"	Societe Lyonnaise de Radiophonie		287	*2,000					
Montpellier	Societe Languedocienne de T. S. F.		186	*100					
Nice	Ministry of Posts		362-460						
Paris	Ecole Superieure de P. T. T.	ESP	458	*2,000					
"	Eiffel Tower, army	FL	2,650	*5,000					
"	Radio Electrique	SFR	1,780	*10,000					
"		SAJ	1,780						
"	Petit Parisien		345	*500					
"			1,780	*15,000					
Pic du Midi			350						
Toulouse	Aerodrome	MRD	1,525						
Tours	Ministry of Posts	YG	2,500	*500					
GERMANY									
Berlin	Konigswusterhausen	LP	330-680	15,000					
"	Telefunken Co.		290-750	12,000					
"	Vox Haus	II	425-505	11,500					
"	Magdeburger Platz (under const.)								
Bremen			330						
Breslau	Schlessischer Rundfunk	GPU	418	11,500					
Cassel			292						
Dresden			280						
Eberswalde									
Frankfort	Sudwest Deutscher Rundfunk Dienst	LP	470	11,500					
Gleiwitz				11,500					
Hamburg	Nordischer Rundfunk	EG	395	11,500					
Hanover			296						
Koenigsburg	Ostmarken Rundfunk	LP	463	11,500					
Leipzig	Mitteldeutscher Rundfunk	MR	454	11,500					
Munster			410	11,500					
Munich	Deutsche Stunde in Bayern	WM	485	11,500					
Norddeich		RAV	1,800						
Nuremberg	Relay		340						
Stettin	Relay (projected)								
Stuttgart	Suddeutscher Rundfunk	OKP	443	11,500					
Waldenburg				11,500					
HAWAII									
Honolulu	Marion A. Mulrony	KGU	270	500					
HUNGARY									
Budapest	Post Office	MTI	950	*250					
"	Post Office	HB	950	*1,100					

(1) Indicates input.
(2) - Radio division.

States and Cities	Owner	Call Letters	Wave Length (Meters)	Power (Watts)	Date	Time Received	Dial 1	Dial 2	Dial 3
INDIA									
Bombay	Bombay Presidency Radio Club	2FV	400	*1,500					
Calcutta	Radio Club of Bengal	2BZ	800	*500					
"		5AF	425						
Madras	Radio Club of Madras (projected)								
Rangoon	Radio Club of Burma (projected)								
IRISH FREE STATE									
Cork	Projected								
Dublin	Projected								
ITALY									
Milan	Proj., Union Radiofonica Italiana		384	1,600					
Naples	Projected		392	1,600					
Rome	Unione Radiofonica Italiana	IRO	425	1,600					
JAPAN									
Nagoya	Nagoya Radio Broadcasting Co.	JOCK	360						
Osaka	Osaka Radio Broadcasting Co.		385	500					
"	Osaka Radio Broadcasting Co. (projected)		385	1,500					
Tokyo			375	1,000					
KWANGTUNG Leased Terr.									
Dairen	Projected								
LATVIA									
Riga	Projected			*2,000					
LITHUANIA									
Kovno	Lithuanian Sales Corporation			5					
"	Under construction								
MEXICO									
Chihuahua	Telephone Company	CZF	325	250					
"	Federal Military Command	FAM	490	1,000					
Guadalajara	Radio Club-Degollado Theatre		280	10					
Mazatlan	Castulo Llamas	CYR	475	250					
Mexico City	Elfrían R. Gomez	CYA	300	500					
" "	Jose J. Reynosa (El Buen Tono)	CYB	275	500					
" "	Miguel S. Castro (La High Life)	CYH	375	100					
" "	Raoul Azcarra (Universal Casa del Radio)	CYL	400	500					
" "	Martinez y Zatina	CYO	425	100					
" "	El Excelsior Parker	CYX	325	500					
" "	Department of Education	CZE	350	500					
Monterre	Roberto Reyes	CYM	275	100					
Oaxaca	Federico Zonilla	CYF	265	100					
Puebla	Augustin del P. Zaenz	CYU	312	100					
Tampico	Cipriano Sagaon	CYQ	322	100					
Yucatan	Partido Socialista del Sureste	CYY	548	100					
MOROCCO									
Casablanca	Radio Club de Maroc	CNO	250	*500					
NETHERLANDS									
Amsterdam	W. Bosman	PX9	1,050	60					
"	Vas Dias Press Office	PCFF	1,950	100					
Bloemendaal	Church		340	100					
Hilversum ¹	Nederlandische Seintoellen Fabriek	HDO	1,050	1,000					
" (-)	Hilversum Draadloze Omroep	HDO	1,050	1,000					
NEW ZEALAND									
Auckland	Newcombe (Ltd.)	1YL	260	*500					
"	Auckland Radio Service	1YA	260	*200					
"	La Gloria Gramophone Co.	1YB	260	*50					

(-)---Separate stations.

States and Cities	Owner	Call Letters	Wave Length (Meters)	Power (Watts)	Date	Times Received	Dial 1	Dial 2	Dial 3
Christchurch				*500					
Dunedin	Otago University	*XO	140						
"	British Electrical & Engineering Co.	4YA	310-370	*500					
"	Radio Supply Co.	4YO	370	*500					
Gisborne	Gisborne Radio Co.	2YM	335	*500					
Wellington	Broadcastings (Ltd.)	2YB	275	*15					
"	Dominion Radio Co.	2YK	275	*500					
NORWAY									
Oslo		OSLO	340-500						
PERU									
Lima	Peruvian Broadcasting Co. (Ltd.)	OAB	360	*1,500					
PHILIPPINE ISLANDS									
Manila	Far Eastern Radio (Inc.)	KZRQ	222	500					
"	F. Johnson Elser	KZUY	370	500					
"	Electrical Supply Co.	KZKZ	270	500					
POLAND									
Warsaw	Government		365	*300					
PORTO RICO									
San Juan	Radio Corp. of Porto Rico	WKAQ	340	500					
PORTUGAL									
Lisbon	Grandes Armazens de Chiado	PIAA	320						
RUSSIA									
Baku	Under construction			2,000					
Chiva	Under construction			2,000					
Elliset	Under construction			2,000					
Erivan	Under construction			2,000					
Tiflis	Under construction			2,000					
Voronezh	Under construction			2,000					
Moscow	Popov		1,010						
"	Trade Union		450						
"	Lubovitch		365						
"	Union of Soviet Workers		675						
"	Comintern		1,450	*12,000					
"	Comintern (under construction)		1,450	50,000					
Leningrad									
Kiev									
SALVADOR									
San Salvador	Projected			500					
SENEGAL									
St. Louis	Radio Club Senegalaise (project.)		300	*100					
SPAIN									
Alcoy									
Barcelona	Radio Barcelona-Hotel Solon	EAJ1	325	*1,500					
Bilbao									
"									
Cadiz		EAJ3	360	*1,000					
"				*100					
Catagena		EBX	1,200						
Madrid	Under construction	EGC	1,650 2,200	*2,000					
"	Radio Iberica	RI	392	*1,500					
"	Radio Madrid	PTT	310	*1,000					
"	Radio Espana	EAJ2	350						
San Sebastian	Projected								
Seville	Radio Club	EAJ5	350	240					
"	Radio Club (under construction)	EAJ5	350	*1,000					

How Uncle Sam is Clearing the Air

By ARTHUR BATCHELLER*

IN the ship service the United States Government has dispensed with the use of the 300 and 450 meter waves entirely, and has limited to calling and distress messages (SOS) the use of the 600 meter wave. The latter was in use previously for routine communication purposes. We had to provide new channels for ship radio communication to replace those which were thus closed to them, and in addition to take care of the constantly increasing radio telegraphic business of this country, and in fact of the world, as ships at sea are continually communicating with our shore stations. Accordingly there have been assigned for ship use the following wavelengths: for distress calls and messages relating thereto—600 meters; for regular marine traffic 706, 750 and 900 meters; for naval radio compass service—800 meters. In the long wave marine bands the following waves have been assigned, 1800, 1900, 2000, 2100 and 2400 meters. This gives for marine radio telegraph service ten wavelengths, the lowest of which is 600 and the highest 2400 meters.

In addition to the above the steamers plying on Long Island Sound have been authorized to use the wavelength of 875 meters, while the shore station at New London, Conn., which works with these steamers has been authorized to use a wavelength of 920 meters. All of these ship stations and all shore stations are required to maintain a listening-in watch on 600 meters for distress calls and messages relating thereto. All shore stations in the Second Radio District except three are equipped with tube or arc (continuous wave) transmitters and have been given new long and short wave assignments so that they are free to operate simultaneously without conflicting with one another.

By a reciprocal agreement entered into between the Governments of the United States, Great Britain and Newfoundland, the ships of these countries are restricted from the use of the 450 meter wave when within 250 miles of their respective shores.

There is still considerable interference caused by the testing of ship radio transmitters at the Port of New York. This testing is necessary, however, in order to determine that the transmitter is operating on its proper wavelengths. It is quite generally recognized that the only reliable means for determining whether or not a radio transmitter is in proper working order

is to test it out on a radiating antenna. While it is true that this is a source of considerable interference, it results in an improvement of the general situation because it provides means for adjusting the transmitters to the exact wavelengths on which they are required to operate, and makes it possible to check up and correct decrement, and other discrepancies which may be found. Every effort is being made to adjust each and every American ship entering the Port of New York.

In order to minimize interference from this source, these testing periods are restricted to the last ten minutes of each half hour, that is, from 20 to 30 minutes past the hour, and from the 50th to the 60th minutes of the hour, thus allowing but 20 minutes in each hour to carry on this important work, although it does not forbid an operator to test his transmitter to determine that it is operating properly just before putting out to sea. However, plans are now under way to restrict ship radio operators from testing their transmitters prior to the vessel's departure for sea, to the 20 minutes allowed under the testing regulations of the port.

Other sources of interference affecting reception are those which emanate from electric railways, transmission lines, smoke precipitators, tree grounds, electric signs, battery charging apparatus, telephone ringing systems, x-ray equipment, curling irons and other domestic electrical equipment. The policy of this office is that when complaints are filed by the broadcast listeners which concern interferences emanating from systems not radio, and not under the control of the Department of Commerce, the matter is always reported directly to the Company controlling the system from which the disturbance originates. In this way a large number of the more serious disturbances have been eliminated through the co-operative efforts of the operating companies and the Supervisor of Radio.

With the abolition of the amateur spark transmitters there has been a decided improvement in the situation, and a great reduction in the interference which has heretofore been experienced from amateur spark transmitters. For some time past the amateurs have been voluntarily replacing their spark transmitters with continuous wave tube transmitters, and at the recent Radio Conference at Wash-

ington, it was recommended that no more licenses for spark transmitters be issued to amateurs. This substitution of continuous wave tube transmitters has not completely eliminated amateur interference, for there are many cases where the broadcast listeners reside in close proximity to amateur transmitting stations and are using receiving apparatus which is supersensitive but not superselective to the same degree. Such receiving apparatus is bound to respond to the amateur signals no matter how sharply defined these signals may be. In such cases we recommend that the broadcast listener employ a wave trap, and I am glad to say that these are being used to good advantage. We occasionally encounter a broadcast listener who is more or less skeptical of the use and value of such a wave trap, because of his belief that it will prevent his receiving D.X. (distant) signals. This is, of course, an erroneous idea.

If we stop for a moment and make a mental survey of the area in and around New York, for instance, the large amount of radio telegraphic and radio telephonic service being constantly carried on, together with the tremendous amount of electrical activity going on in connection with the operation of electric railways, power lines, elevator service in tall buildings, electric signs, etc., we will find it is remarkable that we are able to get such splendid service and enjoyment from broadcasting with such a minimum of interference from local sources.

In summing up we could, with propriety, make a comparison between the radio broadcast service and our great transportation systems, motor vehicular traffic and foot traffic. No one expects to have a train all to himself on the railroad or in the subway, or to have the highway to himself when he goes out with his car on a weekend trip, or to have the full freedom of the sidewalks when we go out to enjoy our noonday lunch. We find obstacles of various degrees and kinds in our way everywhere we go, and we find the same when we come to sit down before our radio sets in the solitude of our homes to enjoy the evening programs. Some interference is bound to ensue, but in the United States we are known as a nation of engineers, and under such regime, broadcasting is going to develop rapidly to its highest point of technical efficiency.

*Supervisor of Radio, Second District.

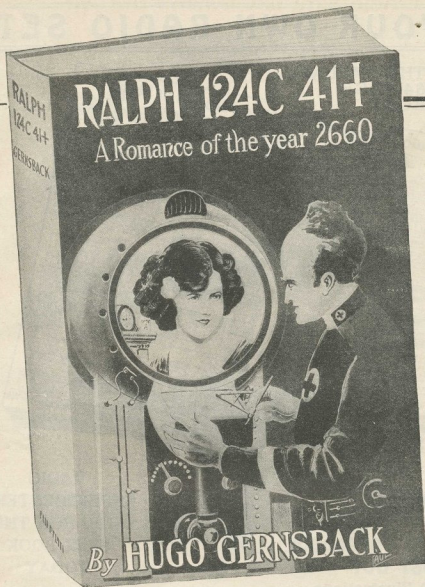

Against an amazing background of mechanical electrical and chemically altered life of mankind there is set a brilliant and colorful romance in the life of the greatest living scientist of that age.

Ralph's love for the beautiful stranger, his conquest of his rival and the worsening of the great saturnine Martian, culminating in a running fight in space with tragedy and terror conquered by almost unbelievable and incredible weapons, make one of the most interesting and gripping stories ever told.

**700
YEARS
HENCE**

IN 1908, Mr. Hugo Gernsback, Editor of *RADIO NEWS*, published the first radio magazine the world had ever seen—"Modern Electrics." In one of these volumes he ran a story entitled "Ralph 124C 41+ A Romance of the Year 2660." This story, although written many years ago, proved more valuable as the years went by, because many of the prophecies made in this book gradually came true.

This was in the days before broadcasting had even been thought of, and before we had the radio telephone, yet all of this is faithfully chronicled in this story.

Old-time readers of "Modern Electrics" probably remember the story, and now have a chance to get the complete book.

A pioneer in the electrical and radio field, Mr. Gernsback has a profound knowledge of the subjects, coupled with a finely trained and highly imaginative mind.

This unusual combination has enabled him to foreshadow

with almost unbelievable accuracy some of the more recent developments. His earlier predictions, which have appeared from time to time during the past decade in many newspapers and magazines, are now realities. Every prophecy is based on accurate scientific knowledge. His ideas are no more fantastic than the realities and commonplaces of our everyday life would have been to our great grandfathers.

—ORDER BLANK—

EXPERIMENTER PUBLISHING CO.,
53 Park Place, New York City.

Gentlemen:—Enclosed find \$..... for which please send me
.....copies of "RALPH 124C 41+" by Hugo Gernsback.

Name

Address

PRICE \$2.15 POSTPAID

S&I 12

THE STRATFORD COMPANY, Publishers

For Sale by

EXPERIMENTER PUBLISHING CO., Inc., 53 Park Place, New York, N. Y.

BUILD YOUR OWN RADIO SET!

FREE THIS VALUABLE 64-PAGE BOOK

Hook-Ups—75 of Them!

Our Motto Is Quick Shipment

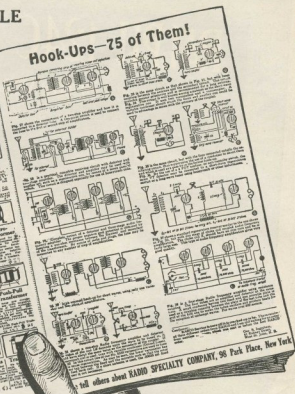
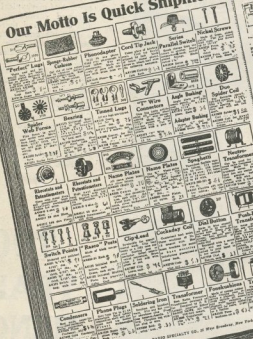

...tell others about RADIO SPECIALTY COMPANY, 98 Park Place, New York

NEW 1926 SPRING CATALOGUE
No. 16 JUST OUT
64 Pages—600 Illustrations

Buy from Radio's oldest Mail Order House

THE NEW RASCO CATALOG No. 16

Contains the Following Hookups:

All Armstrong Circuits: These important circuits are explained clearly, all values having been given, leaving out nothing that could puzzle you. Just to name a few of the Vascum Tube circuits: The V.T. as a detector and one-step amplifier; Super Regenerative one-step radio frequency amplifier and detector; three-stage audio frequency amplifier; short wave regenerative circuit; 4-stage radio frequency amplifier; radio and audio frequency amplifier; inductively coupled amplifier; all Zenith Circuits.

This catalog is crisscrossed full of small parts and radio findings. Literally thousands of them. In addition there is much useful information contained herein.

WE are the oldest established, exclusive radio mail order house in the country. Our motto is "Quick Shipment." All orders are shipped within 24 hours. Quick, prompt, courteous service. We carry a larger variety of radio parts and findings than any other radio variety in the country.

"RASCO HAS IT"

If you are in need of certain small radio parts that other radio and mail order houses do not bother to carry, get the Rasco parts catalog, and you will find them there, anything from a screw to copper ribbon and telephone diaphragms, as well as thou-

sands of other small radio findings. Just to mention a few:

Lugs, nuts, dials, vernier dials, jacks, plugs, every kind of knob, cord, panels, screws, sliders, washers, selenium, tinfil, switches, crystals, cap nuts, Litz wire, cord tips, brass rods, resistances, name plates, spring binding posts, switch parts, metal ribbon, carbon balls, binding posts, all types, switch points, switch levers, lock washers, carbon grains, ground clamps, metal pointers, insulated tubing, low melting metal, antenna connectors, bus bar wire, as well as thousands of others.

WE CARRY THE LARGEST VARIETY OF SMALL RADIO PARTS IN THE WORLD.

If you will paste this coupon on a post card and mail today, we will be pleased to send you our two Catalogues at once.

RADIO SPECIALTY CO. R.R.-5-25
 98-R Park Place, New York.
 You may send for without charge or obligation, your NEW CATALOG No. 16. (Write on margin if you desire).

.....
 Name
 Street
 P. O. State

RADIO SPECIALTY CO.
98R Park Place New York City

What the Beginner Should Know About Radio

By A. M. POWERS*

I'M sit-ting on top of the world, ing a-long,"—comes the voice of your favorite radio artist from your loud speaker or from the head-set clamped to your ears. You hear his voice and so do perhaps many hundreds of thousand others at precisely the same time.

But how does the voice reach you? Newspapers, magazines and casual conversations overheard in public places give the newcomer the impression that the music comes out of the air since they refer to "air" as the medium through which radio waves travel. This, of course, common sense tells us is wrong, for if it did how would Jack Smith be able to get Los Angeles on that super-heterodyne of his with a little loop, and all closed up in the library of his home. Why he would hardly be able to "smell" a local station, outside of getting a program from Los Angeles loud enough to be heard on his loud speaker.

Light and Water Waves Similar to Radio Waves

Some years ago when scientists attacked the problem of light, they found that it did not travel through air. What it did travel through was not apparent, so they decided that there

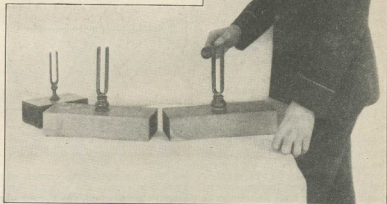

When a tuning fork is struck it sends out sound waves which our ear responds to and we hear the tone. The frequency of these tone waves are low and therefore vibrate at an audible frequency. Various size forks give different pitches which vary the frequency of sound waves.

How would Jack Smith be able to hear a Los Angeles broadcast station on his Super-Heterodyne with a loop aerial if radio waves travel on the "air"? Here we see Jack tuning in on his set in the library of his home with the loop on top of the set and the loud speaker on the table at the left.

To answer this question we are going to try as our first endeavor to explain in as few words as possible how the radio waves travel through great spaces. We might start out by comparing radio waves to that of the old analogy of light and water waves with which we all are probably more or less familiar.

must be some all-pervading substance, and they called this intangible something "ether." Ether at the time was a product of resourceful imagination, but today we find that some of our eminent scientists have somewhat of a further understanding as to what this medium is, particularly in regards to the transmission of radio waves,

while on the other hand we have others contradicting these theories. Therefore, we can hardly say that we are to any great measure more informed than we were years ago. However, we are told that ether is everywhere, the world is surrounded and soaked in it. It is all-pervading. It is neither a gas, liquid nor a solid. It is invisible and odorless.

Now that we at least have some idea as to the ether, let us go back to the subject of waves.

How does ether act to transmit light? It must be pushed, shaken or displaced in some way or another to produce waves. Thus, atoms vibrate in the sun, send out waves in the ether, and when they strike our eyes we say we can see. If we throw a stone into a quiet pond of water, little waves spread out from the source of disturbance in all directions on the surface. (See Figs. 1 and 2.) The size or length of these waves depends on the size of the stone dropped into the pond which may be compared to the varying wave-lengths as referred to in radio. The length of the wave is measured from the peak or crest of one wave to the peak of the next immediately preceding or succeeding wave which in radio is measured in the metric term of meters.

* Written specially for Radio Specialty Co., New York.

In radio we deal also with waves in the ether—waves which resemble the light and water waves. The voice that comes to you from the broadcast station is a voice which has first been

necessary to consider "alternating" and "direct" current such as we speak of them in electrical terms. Many of us use alternating current for lighting purposes in our homes, while others use direct current. The difference between an alternating and direct current is simple. A direct current flows continuously in one direction like water flowing through a pipe while alternating flows first in one direction and then in the other, in a to-and-fro

to be of "low frequency." In some cases it goes back and forth as many as 120 times per second, while in others only 50 times. This frequency may be increased by suitable means, and as a frequency mounts higher and higher, the current grows wilder and wilder in its action until it is rushing back and forth several hundred thousand times per second. When this condition is reached, the current is said to be of "high frequency." Radio waves are generated by such high frequency currents, and it is these currents which form the waves in the ether. The frequency of the number of waves passing a given point in one second as mentioned before in this article is equal to that of the current that produces them, as we will learn later.

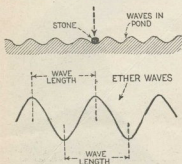

Fig. 1. Above are shown waves produced in water and ether. The wave length of a wave is the distance from the crest of one wave to the crest of another immediately preceding or succeeding it

transformed into ethereal waves, and then back into a voice by means of the receiver.

What Is Meant by "Wave Frequency"

From the foregoing we learn that the length of waves will depend upon the number of waves passing a given point per second, or, we may say their length depends upon their frequency. Small waves may have frequencies as high as ten to fifteen or more a second,

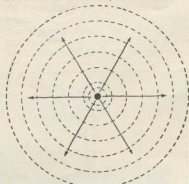

Fig. 2. Looking down from directly above a radio station. The waves are found to spread outward in all directions as indicated by the arrows. This also applies to water waves when a stone is thrown into a pond.

motion. An alternating current can be said to vibrate and when a thing vibrates it always does so at a certain rate or "frequency," another term

High frequency alternating currents vibrate or oscillate rapidly, flowing into the antenna and there setting up radio waves.



This illustration shows how the radio waves are imagined to pass over the earth's surface from a transmitting aerial.

How Inductances, Resistance and Capacity Affect Electric Circuits

It has now been shown that the length of the wave created in the ether depends upon the frequency of the current producing it. If the frequency is extremely high, the resulting ether waves will be short, and if the fre-

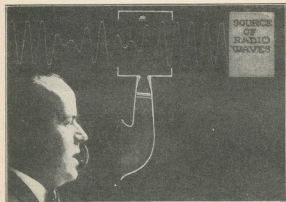

while long waves may have a frequency of but one or two per second. We can understand then that the more waves crowded within a certain area the shorter the waves will be, and we therefore must impress upon our minds that wave-lengths depends upon frequency.

We can now assume that waves are produced in the ether just as they are produced in light or water. An electrical disturbance in the ether also results in waves just as do disturbances caused by the stone dropped in the pond.

Our understanding of ether waves brings us to many byways. It is now

Visualization of modulation of radio waves by sound waves produced through the transmitter. At the right of the sound chamber is shown the unmodulated waves and at the left the modulated voice waves.

Illustrations by The Brady Productions, Inc.

Visualization of radio wave spreading out from the transmitting aerial in all directions. The possibility of showing these waves in their absolute form is of course limited.

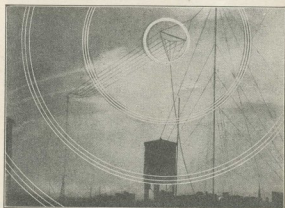

which means much in radio. If a small cork were floating in the pond of water in which we caused the disturbance by the stone, the cork would bob up and down a certain number of times per second according to the frequency of the waves. Alternating current used for lighting purposes is said

frequency of the current is low the waves produced will be long. When a condenser is discharged in a closed circuit, the frequency of the oscillating current will be governed by the inductance, resistance and capacity of the circuit. In general, the greater the inductance and capacity of such a cir-

cuit, the lower the frequency. Inductance is a property of every electrical circuit, but it only shows itself when current is changing. Its action is always such as to oppose the change. Thus, if the current is increasing, the inductance tends to prevent further increase, while if the current is decreasing the inductance tends to oppose further decrease. Therefore, inductance in a circuit would naturally tend to slow up oscillations and reduce the frequency.

"Resistance" is another property of an electric or radio circuit which is equally as important as inductance. Every moving thing, even electricity, meets with some resistance. To roll down a hill, a ball must overcome a certain amount of resistance. A stone thrown through the air also meets with some resistance. And so does electricity meet with resistance when flowing through an electric circuit. The resistance met with here depends upon the nature of the metal making up the wire, the length and size of the wire and other similar electric conductive materials of certain kinds which are in the circuit. The size of the wire is important, because electric currents will flow with greater freedom through a large wire than through a small one, just as in the case of water which flows more rapidly and easily through a large pipe than a small one. If the wire is small the resistance will be high. High-resistance wire is therefore undesirable for conducting electric currents. However, in certain cases high resistance in a circuit is made to perform many important

Electric and radio circuits have still another property which influences the current flowing through them. This is called "capacity." But for the time being we will not attempt to enter deeply into this subject as it will be found more appropriate to discuss it in connection with matters later, so let us now consider an elementary arrangement of apparatus for producing radio waves.

The Simple Method of Producing Radio Waves

Before going into this angle of the subject, let us study the accompanying diagram in Fig. 3, showing a simple arrangement of apparatus which is probably better known as a wireless telegraph transmitting set which our proud amateurs of yesteryear employed to send their dot and dash signals between one another. Here we will see what is known as a key, an induction coil, a condenser, a spark gap, a helix or tuner, a battery, an aerial and a ground. The key is merely a hand-operated switch or a

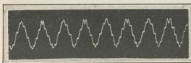

Fig. 4. Sound waves as emitted by a tuning fork and recorded in graph form.

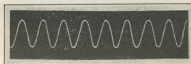

Fig. 5. Sound waves of the vocal sound "ee" as in "seen" recorded in graph form.

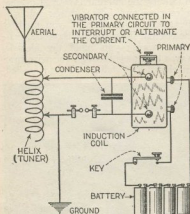

Fig. 3. A simple radio wave producing apparatus as used in transmitting radio telegraphic signals.

duties. When the resistance in a circuit is too great the current loses its force and cannot flow as strongly as under other conditions. Thus it can be easily reasoned why certain resistances are used in electrical and radio circuits to regulate the flow of current by means of introducing or omitting resistance.

When a condenser is "filled" it acts in a peculiar manner. It fills up and discharges. The stored up electricity then rushes across the spark gap from one side of the circuit to the other. This process of rushing back and forth

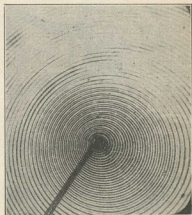

Photo by J. H. Vincent

A photo showing ripples or waves on mercury created by impact of prongs of a tuning fork. This will give the reader a visual idea of how waves spread out from a point of disturbance.

is continued until all the energy stored up in the condenser is used up. When once the condenser is fully "filled" or charged, it can discharge and recharge itself many thousand times in the space of a single second. Each successive charge becomes weaker than the preceding one. However, all this action takes place at a very rapid rate and when the key is pressed, the spark rushes across the spark gap and flows continually until the key is released. When this is done, the current passes through the helix or coil of wire and is emitted through the aerial to generate waves in the ether in all directions.

How We "Tune In" on the Wave-Length

Wave-length in radio corresponds with pitch in sound and with color in light. Sounds are transmitted through the air by bodies that move back and forth or vibrate and thus create a train of waves. If the waves come through the air regularly, we hear a musical note which may be shrill or high-pitched or deep or low-pitched. The pitch depends on how many waves reach our ears in a second, and this in turn depends on how many times the sounding body vibrates the air. When we tighten or loosen the string of a violin we raise or lower its pitch. We call this "tuning." In radio we also speak of "tuning" and when we do we mean simply that we are adjusting the radio pitch of the receiver to the pitch of the transmitting station. In our simple wave producing apparatus previously described, tuning is accomplished by means of adjusting the inductance or introducing a greater or

less means of opening or closing the circuit of the battery and primary of the inductance coil. It is so arranged that dots and dashes can be made with it. By pressing the lever down the circuit is closed and current from the battery flows into the primary of the induction coil or "transformer," a device to increase the voltage of an electric circuit. A pressure of 6 volts may be increased to 60,000 volts. Thus, an induction coil might be regarded as a pump producing a high electrical pressure. When the current issues from the high voltage side or secondary of the induction coil, it has a good deal of sting to it.

The current produced by the induction coil passes into a receptacle called the "condenser" which will hold just so much electricity at a given pressure, in other words, it has a definite "capacity." This brings us to a better understanding of capacity. The capacity depends, among other things, upon the size of the condenser since a large one takes longer to fill than a small one.

lesser amount of inductance in the circuit. This is done by making contact with a desired number of turns of wire on the helix or tuner from the

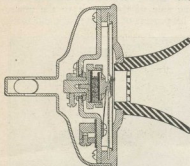

Fig. 6. A cross sectional view of a telephone transmitter showing details of construction.

circuit connected to the "secondary" of the inductance coil in Fig. 3.

Pitch is a matter of wave-length. The smaller the waves and the smaller

one color is "red" and another "blue," we mean that the pitch of the color we call red is lower than the pitch of the color we call blue. In other words, red has a greater wave-length than blue. When we look at the things through a piece of red glass our eyes see with light of one wave-length. When we look through a piece of blue glass, we see things with light of another wave-length. Hence we "tune in" on definite wave-lengths of light when we wear red, yellow or blue spectacles. A radio broadcast station which makes the ether ripple with the voice of our favorite radio tenor on a wave-length of three hundred and sixty meters is like a lighthouse or beacon which send forth beams of red light only. A normal eye can detect all the colors in the rainbow; a color-blind eye cannot. Hence, a tuned receiver is color-blind, in a radio sense. The human eye is a far better "tuner"

which will be as marvelously sensitive as the eye. Between deep red (400 billion vibrations a second) and red-orange (437 billion vibrations a second) is a difference of wave-length far less than between 360 and 361 meters in radio; yet our receiving devices are still so made that we cannot "tune in" more closely than seven meters. A highly trained eye can distinguish about one thousand different tints in the visible spectrum. Far more extensive is the invisible radio spectrum, and radio is still so young that we cannot yet make use of all its tints or wave-lengths.

Turning the Voice Waves into Radio Waves

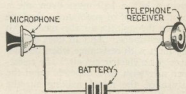

Fig. 7. A simple telephone circuit. The words are spoken into the microphone transmitter cause corresponding variations in the electric current of the circuit and the variations of the current are reproduced by the telephone receiver as sound.

The tuners of a powerful transcontinental radio station. The inductances consist of large spirals of copper ribbon wound on insulating frames. Note the porcelain insulators at different points on the tuners.

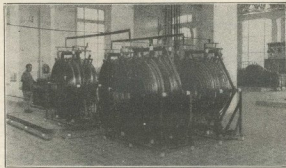
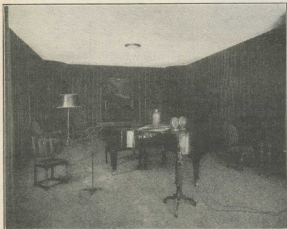

Photo by A. N. Mirzoeff



The concert studio of radio broadcast station WSAL. Fixtures, draperies and furnishings are so arranged to give the best acoustic properties. Note the two microphone transmitters on the pedestal.

Photo by Courtesy of U. S. Playing Card Co.

their length, the more of them strike the receiver, whether it be an eye, an ear or a radio detector. Hence when we "tune in" on a wave-length of three hundred meters in radio we simply adjust the receiving instrument to receive waves of that length, just as a violinist tunes his instrument to agree in pitch with the piano that his accompanist plays.

Wave-length can also be explained in terms of light. When we say that

Control room of radio station WOC showing the complicated panels on which the apparatus for transmitting programs is easily accessible.

Photo by Courtesy of The Palmer School of Chiropractic

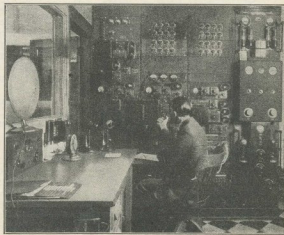

than any we have yet devised for radio reception.

A tuning instrument is wanted

With the invention of methods of generating radio waves such as that based upon the simple apparatus described previously, telephone transmission by radio became not only a possibility but a reality. When you telephone from one part of the city to another you know that your voice is not literally carried over the wire. A current passes through the wire, and in talking the current is varied as the voice rises and falls. When you say the single word "Hello" you modify the current in perhaps a thousand different ways; you mold the electric waves that pass through the wire into an electrical "Hello." This is called

"modulation." In radio telephoning the same process occurs. The waves that are constantly radiated into space

are molded or modulated by the voice. The molded or modulated waves strike the receiver. The telephone translates the modulated waves into modulated sound waves, exactly like those of the singer's voice at the broadcast station.

Why the Aerial Is Used

We now have seen that energy is transmitted in waves whenever anything "vibrates," "alternates" or "oscillates," and that a big alternating or vibrating object will set up bigger waves than a small object. A little rocking boat produces smaller waves than a big rocking boat.

ground. Although the radio or electromagnetic waves pass through glass they meet some resistance. For that matter even the most transparent glass does not transmit all the light that strikes it.

After a while it became the general practice to hang the conductors from tall masts or towers and to call them "aerials" or "antennae." The term was borrowed from entomology. It is applied to the long feelers of insects. And the tall antenna of a great radio station with wires stretched between look for all the world as if they were

form tremendous billows measuring ten and twenty miles from crest to crest. A large tuning fork will be heard farther than a small tuning fork



Photo by Western Electric Co.
A microphone transmitter as used in radio broadcast stations.

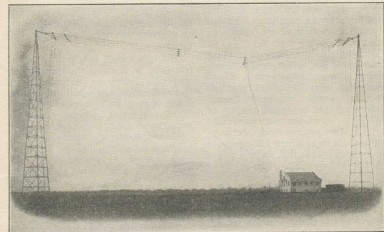

Photo by Courtesy of Washburn-Crosby Co.

A typical broadcast station aerial. This photo shows the aerial of radio station WCCO. The towers are each 300 feet high and 400 feet apart. The building at the right contains the generators and control equipment. Programs transmitted through this station are sent over private telephone lines from studios located several miles away.

It was Marconi who first realized that this applied to radio as well as to boats in water. His tiny spark formed part of a circuit like in our simple wave producing apparatus. As the spark oscillated there was also an oscillation in the wire of that circuit. He discovered that if the wire were stretched between poles or masts it would come in contact with more of the ether and thus shake more of it into waves. The longer the wire the better, for there would be a better chance for the oscillating or alternating current to produce big waves. He

reaching out and trying to feel something in space. They do feel radio waves.

Since amateur stations or broadcast stations are not intended to send sig-

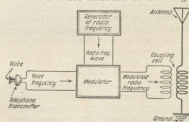

Fig. 9. Diagram of radio telephone transmitting circuit. The telephone transmitter delivers a current having variations of the voice frequency. The current of voice frequency and radio frequency current from the generator are both fed into the modulator which combines the two frequencies and delivers modulated radio frequency currents to the antenna.

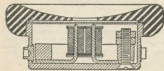

Fig. 8. Cross section of a telephone receiver. A radio phone has the same general construction but is a great deal more sensitive to electric current.

found, too, that the higher the wires, strung between poles or masts, the more effective was the sending and the receiving. This is due to the fact that fewer obstructions are encountered by the waves at a height than at the

nals over distances measured by thousands of miles (although the amateurs have actually been heard in Scotland and further points) their aerials are not so long or tall as those of the great stations that telegraph radio messages to Europe or Japan and have towers several hundred feet high. It is easy to see why the big stations must have such high aerials. They must shake a great deal of the ether in order to

and similarly, high power sent through a large antenna will send waves farther than a small one.

For the same reason the receiving aerial must be large if the detection is to be good. The bigger the waves that beat against a distant receiving aerial, the more powerful are the oscillations received.

In the foregoing explanation the nature of different kinds of waves have been discussed. Every wave has certain characteristic properties, and these are length, frequency, velocity, height, and form. All of these properties may be noted in a water wave. The length is the distance between successive crests; the frequency is the number of crests that pass a given point in a given interval of time; the velocity is the speed with which the wave transmits a disturbance from one point to another; the height is the vertical distance between crest and trough; and the form is the shape assumed by the sides of the wave. The greater the amount of energy that it is transmitting and the greater the amount of work that it can be made to perform.

As a wave spreads out from the point from which it starts, its height becomes less and less, and at a sufficiently great distance it becomes so feeble as to be imperceptible. Thus in the pond of water waves die out as they spread, and so a sound quickly dies out as the listener moves away from its source. The distance to which a wave of a given kind will travel before dying out depends to a certain extent on its frequency.

Sound waves travel in air with a velocity of about 1,090 feet per second. Waves, including light, heat, and radio waves, travel with a velocity of about 186,000 miles per second.

Sound waves are caused by vibrations or to-and-fro motions of some sounding body that creates waves in the air. The vibrating body may be a piano wire, an anvil, a vocal cord,

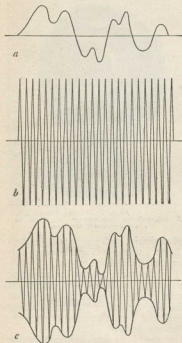

Fig. 10. The wave forms of radio. "a" is the voice frequency from the telephone transmitter. "b" is the radio frequency wave from the generator unit (see diagram of transmitter). "c" is the resultant modulated radio frequency wave delivered to the aerial by the modulator unit.

or any one of an almost infinite variety of objects. The waves sent out by different kinds of vibrating bodies differ greatly in form. Probably the "purest" sounds that we ever hear are emitted by tuning forks, such as piano tuners use. Fig. 4 shows the form of a sound-wave emitted by a tuning fork. Another photo shows waves of a tuning fork as produced in mercury to show the effects of sound.

The waves produced by a piano or a violin are very irregular in shape and not like those produced by a tuning fork. These irregularities, however, are important. They are characteristic, as identifying, as the features of our faces, and make it possible for us to distinguish one musical instrument from another. The frequency of vibration is the number of times that the sounding body vibrates to and fro in a second. As the frequency of vibration increases, the pitch of the sound becomes higher.

Waves Produced by Speech Vibrations

The sounds of the voice are produced by the vocal organs, including the vocal cords, and the throat, mouth and

nose cavities. The vibrations of the vocal cords are similar to those of the strings of a violin, but are more complicated. The air in the throat, mouth, and nose cavities vibrates like the air in a very small organ-pipe. For producing each distinct sound, our vocal organs are used in an entirely different way. The vowel sounds, such as A, E, I, O, U, are produced by different combinations of the vibrations of the vocal cords, and vibrations of the air in the cavities of the throat, mouth and nose. The consonant sounds such as "s," "c," "b" and "f" are hissing, breathing and explosive sounds caused by air rushing past the tongue and lips. Speech waves are even more irregular in shape than most of the sounds of music.

With suitable apparatus we can take a picture of the sound waves corresponding to a particular sound. Fig. 5 shows the vibrations that constitute the vowel sound "ee" as in "seen." Each word that we speak consists of a whole series of irregular waves like this. If two people speak the same word, there is sufficient difference in the sound waves so that the two voices can be distinguished. The pitch of the voice is determined by the nature of the vocal cords. The pitch of a woman's voice is usually higher than that of a man's. The average pitch of the voice is perhaps as low as 200 vibrations per second, but some sounds like "s" involve frequencies of several thousand.

Hearing the Sound Waves

Sound waves that reach the ear cause the ear-drum to vibrate just as the source of the sound vibrates, and thus the sound is reproduced. The movements of the ear-drum are transmitted through the little bones of the inner ear and finally reach the hearing center of the brain through the nerves.

The ear can best hear sounds that have frequencies varying between 1,000 and 4,000 per second. Sounds can be heard, however, which have frequencies between the extreme limits of 16 vibrations and 32,000 vibrations per second, but for these extreme limits it takes a great deal more energy to make a sound wave audible. The ear cannot hear sounds having frequencies greater than 32,000. Some of the vibrations produced by crickets have frequencies so high that they cannot be heard by the human ear. The frequency of the radio waves employed in radio broadcasting greatly exceeds 32,000. In radio work it is very convenient to differentiate the two classes "radio" frequencies and "audio" frequencies. The "audio" frequencies or voice frequencies are the frequencies which can be heard; that is, the ones that are audible; the "radio" frequencies are the higher frequencies that cannot be heard.

The Telephone's Role in Radio

Sound waves die out rapidly and cannot be heard at a short distance from the source. By using devices such as a speaking mouth-piece and a horn, the distance can be somewhat increased, but it is still small. Sound waves are absorbed by the many objects that lie in their paths; these objects are set into vibration as the sound waves beat upon them. To transmit or communicate over any but very short distances, it is necessary to make use of means other than sound waves. Electric transmission is the most important means of communicating over long distances. The ordinary electric telephone is the most important means of carrying the voice over such distances.

Ordinary speech is a kind of sound telephony with air as the transmitting medium. Telephony over wires is so like radio telephony which, of course, is the same as radio broadcasting, and the fundamental principles involved are so much alike, that it will be worth while to consider the operation of the ordinary telephone, and see just what each part of the system does. The problem in any form of electrical telephony is to reproduce electrically at the distant receiving station the complex sound wave spoken into the transmitter.

The essential parts of a simple telephone system are a device called a "transmitter," by means of which sound vibrations cause corresponding

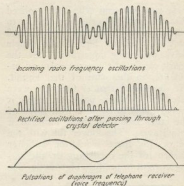

Wave forms in the receiving circuit. The detector allows only the top half of each oscillation to pass and the bottom is cut off. The rectified oscillations are smoothed out and cause the diaphragm of the telephone receiver to pulsate at voice frequency.

variations of an electric current, a device called a telephone "receiver" for changing the electric current variations back into the corresponding sounds, and an electric circuit for connecting the two devices. The microphone transmitter or "mike" as it has been called, into which our radio artist sings is simply an extremely sensitive telephone transmitter.

How the Microphone Transmitter Operates

The telephone transmitter into which we speak is merely a speech-controlled valve that turns the electric current on and off. Fig. 6 shows the construction of a transmitter. The sound waves beat upon a thin piece of metal called the "diaphragm," and cause vibrations of the diaphragm corresponding to the voice. Back of the diaphragm is mounted a "transmitter button," which is really a little cup containing small granules of carbon. At the back of the cup is a carbon plate, called the "back electrode." The front wall or cover of the cup is movable, but fits tightly in the cup. The front electrode is attached to the diaphragm, and moves in accordance with the motions of the diaphragm. A low voltage, as from a few dry cells, is connected with the front and back electrodes. The mass of carbon granules has this property: when the granules are pressed somewhat together by a little pressure, their electrical resistance decreases to a marked degree. As the diaphragm and the front electrode move back and forth in response to the voice, the pressure on the carbon granules varies; hence the resistance varies, and the current flowing through the transmitter varies ac-

At the receiving end of the circuit we must have a device for changing the variations of the electric current back into sound waves. This is the telephone receiver. The telephone receiver is essentially an electromagnet, that is, a magnet the magnetism of which is controlled by an electric current.

The ordinary telephone receiver, as shown in Fig. 8 consists of two coils of wire wound around the poles of a permanent magnet, and an iron diaphragm held in place near the poles of the magnet by its magnetism. If the two coils are connected in the circuit in the right way, the magnetic field of both coils will act in the same

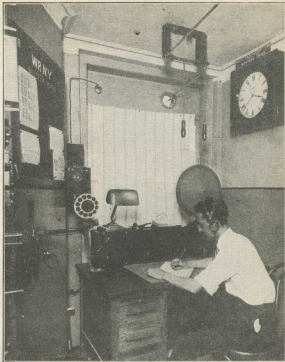

Photo by Courtesy of The Experimenter Pub. Co.
The operating room of radio station WENY. The aerial lead-in and lighting switch can be seen above the window. An operator is constantly on watch at the receiving set for "808" call to cease broadcasting.

electric current and hence with the sound impressed upon the transmitter or microphone. The voice at the transmitter end of the circuit in Fig. 7 is thus reproduced in the receiver at the other end. The process of this transmission is almost instantaneous.

Voice Transmission by Radio

By this time the reader will question

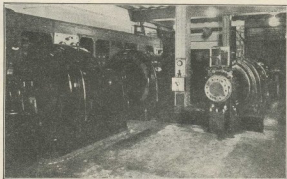

Photo by Courtesy of The Palmer School of Chiropractic.

Seven and a half tons of apparatus are used to produce the powerful radio broadcasting waves from radio station WOC. The large vacuum tubes can be seen through the glass fronts of the center panels.

The powerful generators of a transcontinental radio station. These generators produce the necessary energy required to project radio waves across the Atlantic ocean.

Photo by
A. N. Mirzoff



cordingly. When the diaphragm is in its normal position of rest, a certain unvarying current will flow in the circuit. When a sound causes the diaphragm to vibrate, the current flowing in the line varies exactly in accordance with the wave form of the sound. The process may be thought of as a moulding of the normal unvarying current to the form of the impressed sound wave. It is important to note that the sound waves beating on the diaphragm do not themselves generate any electric current, but simply control and vary a current which is already flowing.

A circuit connecting the telephone transmitter with a telephone or radio receiver is shown in Fig. 7 and is given here in order to illustrate more clearly the transmitter's operation as well as the receiver which will be taken up later

direction, and the effect of a current flowing in one direction will be to increase the normal magnetism of the magnet, and the effect of a current flowing in the opposite direction will be to decrease its magnetism. When the current flows in the one direction, the diaphragm will be pulled closer to the poles from its normal position, and when the current flows in the other direction the pull will be decreased and the diaphragm will assume a position not so close to the poles as its normal position, when no current is flowing. The diaphragm will move in and out as the current in the coils varies, and in a telephone receiver the diaphragm will respond very promptly and accurately to the variations in the current. The motion of the diaphragm causes a sound in the air, which corresponds with the variations in the

the fundamental difficulties of producing voice waves at low frequencies into high frequency radio waves. However, let us consider what we

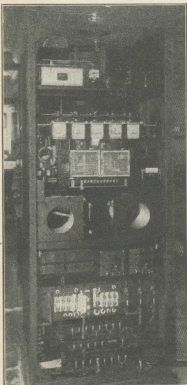

A rear view of a 1000-watt transmitter equipment at station WWJ. The tuning inductance can be seen in the uppermost part of the unit. Condensers and other incidental parts are arranged below.

have already learned about the production of high frequency currents and note the circuit shown in Fig. 9. We will shortly reach the point where we will have a complete understanding as to how the voice vibrations are converted into high frequency radio waves and then radiated out into the ether by way of the aerial.

We have seen that low frequency current can be readily boosted into a high frequency current suitable to produce radio waves by means of the simple radio telegraph apparatus in Fig. 3 and also how tuning is affected. The problem now simply resorts itself into the process of "modulating" the high frequency radio wave. The familiar vacuum tube usually accomplishes this. The sizes of the vacuum tubes used in radio broadcast stations, of course, greatly exceed the proportions of those used in your radio receiving set. An explanation of vacuum tube principles and operation will be discussed later.

The arrangement for producing the modulated wave is shown in Fig. 9. To go into details of the actual apparatus employed here would be too complicated and confusing for the lay-

man, therefore only a general diagram of units is given. Into the modulator there is fed both the unmodulated high radio frequency current from the "oscillator," another vacuum tube device, and the current from the telephone or microphone transmitter which is varying at low voice frequencies. These two currents are combined in the modulator unit, from which results the modulated radio frequency wave which is radiated out into space. The telephone transmitter used may be the same type that is employed in telephony over wires, as has been described before.

The three wave forms are shown in Fig. 10. The voice wave produced by the transmitter is shown at a. The modulated radio frequency wave produced by the oscillator is shown at b, and the modulated radio frequency wave which is radiated out into space is shown at c. It is evident that the effect of the process of modulation has simply been to vary the height or amplitude of the radio frequency wave to correspond with the voice wave, the

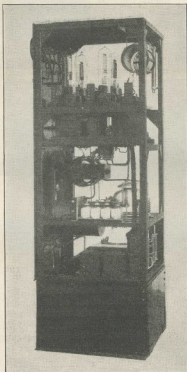

Photo by Courtesy of Western Electric Co.

A side view of the 500-watt transmitter unit shown at the right. In the top compartment are the twin 250-watt oscillator and modulator tubes, and a 50-watt speech amplifier tube; and the antenna tuning coil. In the third compartment are the coils and condensers for the oscillating circuit, and a variable condenser in the oscillator plate circuit. Resistances, choke coils and transformers make up the rest of the apparatus.

mountains of voice wave corresponding with the large amplitudes of the modulated radio wave, and the valleys of the voice wave corresponding with

the small amplitudes of the modulated radio frequency wave.

In order to secure the most effective radiation of the radio waves into space, it is necessary to use an antenna, which has been briefly described before.

Let us summarize what we have learned thus far. We speak. The particles of air in our vicinity vibrate back and forth. For each back-and-forth motion there is a mountain and a valley in the modulated radio waves

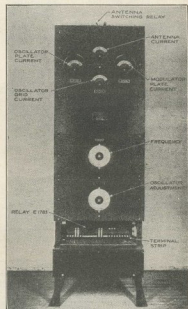

Front view of a 500-watt broadcast transmitter such as used at radio station WJNY. See opposite page for diagram of complete 500-watt broadcast equipment.

which are radiated. Between the crests of successive radio waves there is a distance of perhaps 300 meters, or less than a quarter of a mile, but the distance in space from one of our voice-wave mountain peaks to the next will probably be between one hundred and one thousand miles.

It has not yet been explained how we can detect these radio waves which have been radiated into space, and how to reconvert them into sound waves which will produce the words spoken at the transmitting station. It is first necessary to tune the receiving circuit as previously explained, and make use of a crystal detector or vacuum tube detector which rectifies the modulated radio waves and thus makes them audible in the telephone receiver or amplified to operate a loud speaker.

How the Radio Waves Are Received

The radio waves are intercepted at any given point within range of the transmitting station. If we throw a small cork into the pond of water as described for our analogy on the production of waves, the cork will natur-

ally bob up and down on the surface in no matter what location it is when waves are produced by a stone thrown into the pond. Obviously, the waves become weaker and weaker as they travel out from the transmitter. Thus a receiving set will respond to waves in all locations. The method of tuning in on the wave-length or selecting a desired station may be likened to tuning in on light and sound waves.

The Crystal Detector and the Telephone Receiver

All that is needed to receive radio waves is an antenna connected with a circuit tuned to the radio frequency wave which it desires to receive, and

Suppose that the telephone receiver and the tuning coil are connected directly in series between the antenna and the ground, and that the tuning coil is tuned to the wave-length of the wave which it is desired to receive, but that no other apparatus is present. The incoming wave will have a frequency of perhaps a million cycles per second. If there were an extremely light and sensitive device which could vibrate a million times a second, it could be connected in the circuit and would respond to the incoming wave and vibrate at the wave's frequency. But the diaphragm of the telephone receiver is not nearly light enough to respond to so high a frequency. Dur-

ear would not perceive any sound because the frequency is far above the highest audible frequency.

If the incoming wave is a high frequency radio frequency wave having a frequency of a million cycles per second, which is modulated by a sound having a frequency of three hundred cycles per second, the sound cannot be made audible in the telephone receivers with the apparatus mentioned above. But if we could devise some kind of valve which would pass only the halves of waves acting to pull the diaphragm in one direction, and would prevent the other halves of the waves from acting on the diaphragm, we could accom-

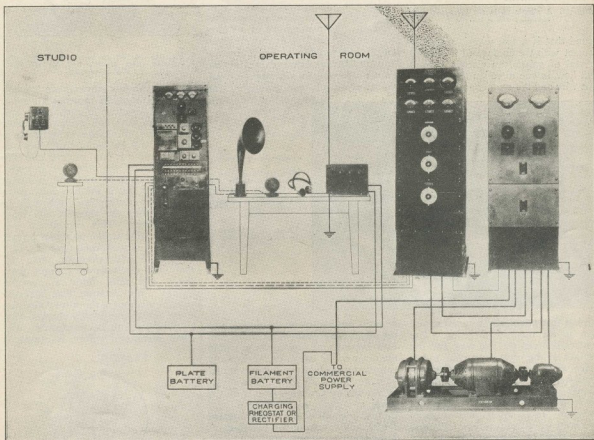

Here you see what really counts in the broadcast station. A typical layout of the 500-watt Western Electric broadcast equipment such as installed at radio broadcast station WRNY. At left is the announcer's local telephone set, and the "mike" that picks up the program. Then comes the speech amplifier panel, with its control dials, meters, etc. On the operator's table is the monitoring loud speaker, another microphone, the headset and radio receiver for "listening in" at 600 meters. At the right are the 500-watt radio transmitter with its three dials for antenna tuning, wave length and oscillator adjustment; and the power control panel. Below is the motor-generator set which delivers current for filament and plate circuits in the transmitter.

Photo by Courtesy of Western Electric Co.

means for making the radio frequency current audible. In a foregoing article "tuning-in" on the waves has been explained. The antenna used for reception may be any one of the various forms, the most popular being a single wire suspended in the air between two insulators. The radio wave which arrives at the receiving station causes a corresponding alternating current to flow in the antenna and the circuit connected with it.

ing one-half of each radio frequency wave the diaphragm is subjected to an outward force and during the other half it is subjected to an inward pull, but the duration of these forces is so short that the diaphragm does not have time to get started moving in one direction before it is pulled in the other direction. And even if the diaphragm were so light that it could accurately follow these very rapid changes in the magnetic force acting on it, the

plish our result. During each three-hundredth of a second, the diaphragm would be acted upon by over three thousand impulses acting in the same direction, and the effect of these impulses would add up and pull the diaphragm, and the sound transmitted could thus be made audible.

There are several devices which act as such an electrical valve. The most important of these are the crystal detector and the vacuum tube.

Crystals for Use as Detectors of Radio Waves

Galena is a native mineral, and is an important lead ore. It has been

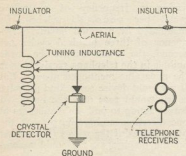

Fig. 11. A simple radio set for receiving incoming radio waves.

found that if a fine wire is placed in contact with the surface of a selected crystal of galena, an electric current will flow in one direction through the fine wire and the contact and the crys-

The first step is to tune in on the incoming wave so as to bring it in harmony or "resonance" with the wavelength of the broadcast station like that of tuning in on a desired color or tone pitch. When this is done, the intercepted waves flow down from the receiving aerial to the ground. They may be diverted into the receiving apparatus as illustrated. However, even when they are diverted in this manner these wave energies are still of frequencies several hundred thousand vibrations per second corresponding to the wave-length of the transmitter, and will not produce any sounds in the usual telephone receiver (Fig. 8), which will only respond within a range of audible or considerably lower frequencies. By making use of a detector that can "rectify" or convert these electric waves into a direct current (current flowing in one direction), we secure a series of vibrations or impulses flowing in one direction. The

of matter so small as to be invisible even with the most powerful microscopes, are made up of even smaller portions called electrons, and it is with these electrons that we are concerned. As an electron is so small that it is almost impossible to conceive of its minuteness, it is best to think of it as a charge of electricity.

It is also fitting at this point to explain the nature of a charge, when speaking about electricity. When the

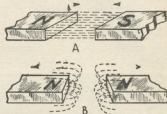
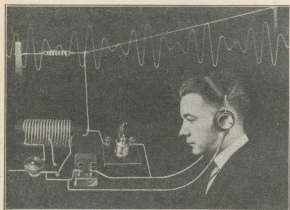

Fig. 12. At "A" the magnetic process of opposite poles attract, and at "B" the like poles repel.

ends of two bar magnets are touched together they will sometimes have a tendency to cling to each other and sometimes they will push each other away. If this little experiment is tried, it will be found that when the north pole of one magnet and the south pole of the other are in proximity, the magnets will tend to attract each other, but if the two north poles or the two south poles are brought in contact, then the magnets will repel one another. This experiment will show us, that unlike polarities attract and like polarities repel. (See Fig. 12.)

So it is with electrons. We say that some electrons are charged positively, and some have a negative charge. The electrons that have the positive charge are the more stable and those that are negatively charged may be considered to be wanderers. The atom, mentioned before, is composed



Pictorial illustration of a simple receiving outfit, showing an arrested visualization of the modulated radio waves reaching the receiving aerial.

Photo by The Brady Productions, Inc.

tal, but that practically no current will flow in the opposite direction. The contact between the fine wire and the surface of the crystal acts like a flap valve which lets water pass in one direction only in a pipe. Iron pyrites or "fool's gold," also acts in this way. Such minerals are called "crystal detectors." It is by no means every specimen of either of these minerals that will act as a crystal detector, and it is not every spot on the surface of a given crystal that will give a contact that will act as a detector, and pass current only in one direction. A good crystal must be selected, and then the surface of the crystal must be searched with the fine wire to find a spot which is satisfactory.

A short distance away the waves may be intercepted or detected by means of the simple receiving set shown in Fig. 11; but at greater distances when the waves are considerably weaker the more elaborate vacuum tube arrangements are usually employed.

current flowing from the detector to the telephone receiver is smoothed out into impulses at a frequency within the range of the telephone receiver and causes vibrations of its diaphragm that can be heard by the human ear. When the proper adjustments of the tuner are made to correspond with the wave-length of the desired station the sounds as transmitted are distinctly heard.

The Vacuum Tube and Its Use in Radio

Vacuum tubes are used in every station that broadcasts programs as described in connection with "modulation" of waves. The tubes are used to strengthen the music before it is broadcast, and at the receiving end they are again used for detecting and amplifying the waves after their journey through the ether. The question now arises how does the vacuum tube work. To answer this it will be necessary to start with the smallest particles of matter known as "atoms."

Atoms, which are minute particles

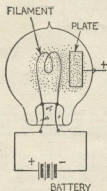

Fig. 13. A diagram showing how the electrons flow from the filament to the plate of a two-element vacuum tube.

of electrons that have either positive or negative charges. There are, at the center of each atom, electrons that have a positive charge of such a strength that they hold negatively

charged electrons that are revolving about them in regular orbits. In other words, the structure of the atom may be compared to the solar system of which the earth is a part. The sun may be thought of as the positive nucleus at the center of the atom and the negative electrons as the planets that revolve in their orbits about the sun. The attraction of the sun which holds the earth in its path may also be likened to the force that the positive nucleus exerts on the traveling negative electrons.

However, under certain conditions, when outside forces are brought to bear on the atom, the force holding the negative electrons in place is overcome and they fly away to some object that has a greater positive charge than the positive nucleus.

The Filament Employed to Emit Electrons

This characteristic of electrons was first applied to vacuum tubes by an English scientist, Prof. Fleming, in 1904. He suspended a fine wire attached to a battery near a metal "plate," which could also be attached to a battery, and enclosed the two elements in a glass tube from which the air was removed. When the battery

Fleming tube, found that by placing another element in it more wonderful things than ever could be performed. This third element was another wire strung spirally between the filament and the plate and was named the grid. The function of this discovery of Dr. DeForest's is to act as a control for the electrons that flow from the filament to the plate. (Fig. 14).

The Action of a Tube Likened to a Water Pump

If we compare the action of the vacuum tube to the valve of a water-pump, it will doubtless make matters clearer. In a water-pump, there is a valve which permits water to flow in one direction only. That is, when the stroke of the pump plunger is downward, the valve opens, allowing the water to flow into the chamber. When the pump plunger is started on its up-stroke the pressure of the water is exerted on the valve, which closes, the water then being lifted to the top of the pipe. There might also be a gate-valve in the pipe between the pump plunger and the outlet, which would regulate the flow of water. (Fig. 15).

These parts of a pump and their functions may easily be compared to

outlet may be considered as the grid of the tube, because the function of the grid is to regulate the flow of elec-

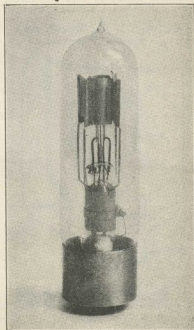
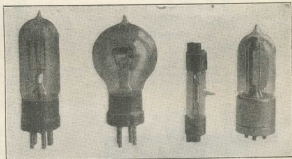

Photo by Courtesy of General Electric Co. One type of transmitting vacuum tube as used in connection with medium power transmitting sets.

Various types of vacuum tubes as used for receiving purposes. As seen these tubes differ as to their size and shape. However, they all incorporate the same principle.



was attached to the thin wire, which he called the "filament," the wire grew warm. As the positive terminal of another battery was connected to the plate, he discovered that there was a flow of current between the filament and the plate as in Fig. 13.

This current flow was caused by the heating of the filament to a temperature at which the positive nucleus could no longer exert sufficient attraction upon some of the negative electrons and they flew off into space. As we have seen above, unlike charges attract each other, the negative electrons thrown off from the filament went across the intervening space to the positively charged plate. Also, as the plate was always charged positively with respect to the filament, the electrons always flowed in one direction, i.e., from the filament to the plate.

In 1907 Dr. Lee DeForest, while experimenting with the two-element

Successive stages in the manufacture of a dry cell vacuum tube showing how the elements are arranged with the glass vacuum bulb. From left to right are the plate, grid, filament on support, assembled elements, elements within tube and finally the completed tube.

Photo by Courtesy of Radio Corporation of America

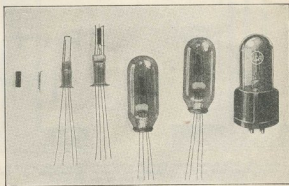

the three elements of a vacuum tube. The one-way action of the pump may be compared to the unidirectional flow of electrons from the filament to the plate, which may be thought of as the outlet of the pipe. The gate-valve mentioned between the pump and the

trons, as the gate-valve regulates the flow of water.

This regulation or control of the electronic stream is easily understood if one considers the relative electric charges on the grid and plate elements, i.e., the plate being charged positively with respect to the filament, attracts electrons when they are shot off into space from the filament. However, as the grid is between the filament and the plate and as this element, too, may be given an electric charge, it influences the electronic stream in the fol-

lowing manner: If the grid is charged positively with respect to the filament and negatively with respect to the plate, then it will attract to itself a certain number of electrons, the rest of the electrons in the stream continuing their journey on to the plate. Now

if the grid is charged negatively with respect to the plate and has the same charge as the filament it will allow the electronic stream to pass unchanged,

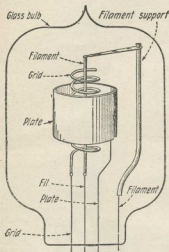

Within the vacuum bulb of the tube are the filament, grid and plate elements. The wires connected to them are brought out to leg contacts on the bottom of the tube base.

or the number of electrons reaching the plate will be greater. If the grid and the plate are identically charged the electrons will stop at the grid, not continuing their journey any farther.

This may seem confusing, but if the reader will remember that like charges repel and unlike charges attract, then he should have no trouble in understanding the part the grid plays in the

The Vacuum Tube as a Detector

Primarily there is the vacuum tube that is used as a detector. If a circuit diagram of a receiver is considered, it will be found that there are always two wires on the input side of the detector tube, one of these leading to the grid and the other to one of the two filament terminals. In most cases, these two wires are connected to the ends of some form of inductance, whether it be the secondary side of a radio frequency transformer or the secondary of coupling coils.

Superimposing Currents

The current passing through these wires is an alternating current varying

words or music being projected into the microphone at a broadcast station, are the components of the whole that cause the detector to function. They cause the first-mentioned current, which is commonly called the carrier wave, to vary in intensity. That is to say, at some instant the carrier wave will have a greater positive (or negative) value than at some other instant. This variation of the carrier wave is called "modulation," as previously described.

When this modulated carrier wave is impressed on the grid of the detector tube, it will cause the charge of the grid to vary, making it more or less

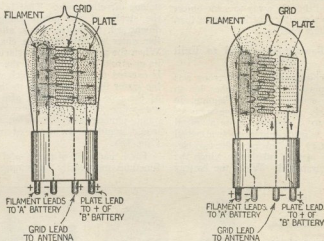

Fig. 14. A pictorial illustration showing what happens in a vacuum tube when the polarities of the batteries are connected to allow the electrons from the filament to flow to the plate and at the right shows what the reversal of the battery polarities does.

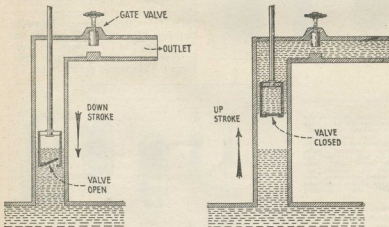

Fig. 15. In a water pump there is a valve which permits water to flow in one direction only. Thus this action is likened to that of the vacuum tube which permits currents to flow in one direction.

vacuum tube. Of course, there are many variations that enter into the grid and plate function that are entirely too technical to be discussed here. However, it might be fitting to explain a few of the uses of vacuum tubes in receiving circuits.

its polarity, or direction of flow, thousands of times per second. Superimposed on this alternating current is a second current, which is irregularly alternating, whereas the first current is uniform. The variations in the second current, which are caused by

negative (or positive, as the case may be) with respect to the filament. As has been explained above, the grid of the tube acts as a control valve for the electronic stream flowing from the filament to the plate, according to the nature of the charge upon the grid. So if the value of the charge of grid varies as the modulated carrier wave, then the electronic stream will vary in exactly the same manner. In other words, the function of a detector tube is to convert the modulated carrier wave, which is alternating at radio (high) frequency, to the modulated audio frequency current that we are able to hear in the headphones or loud speaker as voice or music, etc.

The Vacuum Tube in Amplifier Circuits of the Receiver

When vacuum tubes are used either in the radio or audio frequency amplifiers, their purpose is entirely different. The tubes are then employed because it is possible, by their use, to make a small amount of energy control a large amount of energy, in
(Continued on page 158)

The How and Why of Radio Code

By GILSON V. WILLETS*

WERE you ever listening-in to some beautiful concert when suddenly the program was interrupted with a most annoying noise coming with symmetrical regularity consisting of long and short impulses that seemed to fairly wreck your delicate receiver? "Dit-Dah-Dit-Dah-Dit-Dah," it goes in a series of dots and dashes which

wide society, the object of which was to force the government to either remove radio from all ships or to compel them to use radiophone so what they said could at least be understood by "intelligent" people. The man in question sent his propaganda to several of the prominent broadcast stations and much to his surprise his idea was dis-

using their transmitters, *forced oscillations* will be heard on every wave within the range of your receiver. This is because the power is so strong at the transmitter that "Spark" signals leak through everywhere. In New York harbor during the day, the U. S. Department of Commerce has radio inspectors adjusting the radio transmit-

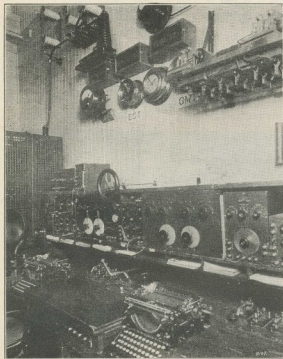

Photo by Thomas Cook Knight

The S.S. Leviathan is probably the most completely equipped steamship in the world and here we have a glimpse of a corner of her transmission room. Particular attention is called to the fact that the installation consists of three transmitters.



Photo by K. and H.

Here we see the antenna system on one of Uncle Sam's battleships. It will be interesting to note that like the mighty Leviathan, Uncle Sam's battleships are equipped with the latest word in modern methods radio communication.

you've learned are radio code signals presumably emanating from a ship at sea. You probably frown and try to tune the offending signals out by seeking another station on a lower wavelength. Sometimes you are able to do this and sometimes the code seems to be everywhere on your dials. Should it be everywhere you may probably close up your set for the evening and go to the movies telling your friends the set is no good or that you advocate a new law to suppress this distraction from your radio enjoyment. Many, very many, have written their senators and representatives in Washington urging just such a measure. In 1922 a man in Maryland organized a nation-

pleasing to them and in many instances he was severely criticised.

In time the problem of code interference will be eliminated and the air will be free for the complete enjoyment of radio programs, but this will take some time. Meanwhile, let us seek the reason for this interference and why it hinders uninterrupted reception in our homes.

Contrary to whatever statements have been made by manufacturers today there are no receiving sets made to operate on the regular broadcast wave-bands that do not occasionally pick up code signals. This is because in localities near powerful ship-shore stations or where ships pass

ters of ships in the harbor. In order to properly adjust the waves of these ships to avoid future interference it becomes necessary to throw the power on the air for periods of as long as a minute or more at a time while adjustments are made. In most sections of the city these signals drown out everything in the upper broadcast bands and cause dealers the loss of many sales during the daylight hours. The government will not itself, nor will it permit anyone else to, thus test during the regular evening broadcast periods.

There are several kinds of radio transmitters that employ the "Code" which is absolutely necessary because

*Former Engineer, Stations WOS, WOC and WRNY

voice is impracticable: The possibility of phonetic error is too great and besides code is the most accurate method we have today, next to the written word, of exchanging intelligence. Could you imagine a code message like this "XXSDG, QWTRX,

ing all spark type sets over into tube or arc sets and within a score of months the interference from that source will be practically nil.

However, the arc and tube transmitters have greater range and reliability and are far more desirable in every

aircraft and inter-city radio traffic.

A certain man once spent an evening at the writer's elbow cursing the "Damfool" ships that ruined his evening on a rather poorly constructed broad tuning receiver of a well-known make. Later, an SOS call was received from the S.S. *Lenape*, and the writer copied for him the various messages sent in connection with the disaster. His daughter was on board the *Lenape*. At once the ship's radio assumed the greatest importance. He was so happy that the broad undamped wave of the KVL (call of the *Lenape*) was audible to thousands of vigilant land and ship stations. When sending an SOS call a ship transmitter is always tuned as broad as possible to enable the greatest number of listeners to hear the call. The anxious father watched with longing eyes, filled with love and horror, the grim messages copied from the *Lenape* and the rescue ships and when he learned, via his own radio, that his beloved daughter was safe along with all the other pas-

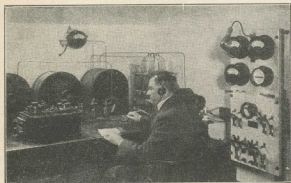

Here is an old-fashioned spark type transmitting station which has been for years out-classed by modern tube transmitters. This station which at one time operated in Binghamton would cause interference for miles around whenever it operated, and was such a station to be used today, it would completely ruin broadcasting reception in its vicinity. Photo courtesy D. L. & W. Railroad.

SQZXC, DFGJK," being sent in static-filled air and bad interference in voice? No! The code must positively be used and we owe our thanks to Samuel F. B. Morse for its inception although the radio code was not all conceived by him as the Morse code is only used on the railroad and telegraph systems of the country and an evolution of it, known as the Continental Code, is used by all cables of the world, by all the telegraph land lines of continental Europe and by all the radio stations of the world by international agreement. In the early days of wireless when Marconi was conducting his tests and for a few years afterwards, the Morse code was used, but it was supplemented by the more practical Continental code because it has no spaces in the characters comprising the letters. See the two codes as outlined on the code chart on page 95 and note the "O." In Morse it is "Dot space Dot," but in Continental it is "Three Dashes." This is more simple and easy to receive through bad static and also there is no possibility of mistaking the Morse "O" for the Morse "I" which is "Two Dots" without spaces between.

Another thing of interest is the types of transmitters used today by ships and land stations. They are divided into the following classes: *spark* (using damped waves which are very interfering), *arc* and *tube* (which are both very sharply tuned and cause but little interference when properly adjusted), and *chopper systems* (which utilize a method for breaking up the undamped waves of the *arc* or tube transmitters, making them audible for non-oscillating receivers and which are not quite as interfering as sparks and much more desirable). The governments of the world co-operating with private interests are gradually chang-

way in addition to being non-interfering.

One of the most important things to be considered is that no matter how

And here we have a radio installation on board an airship which of course is the only means they have of communicating with the world below, and therefore we must admit is of more importance than a simple broadcasting station. Photo by P. and A.



much the broadcast listener may consider his own importance in the matter, that same person sings a far different tune should he be a passenger aboard a ship at sea that meets with accident, for then the radio becomes a vastly important thing in his eyes. Big business men that roast the interfering ships turn and beg the operators on these same ships to keep them in touch with their home interests when they take a "hop abroad." While the broadcasting of entertainment has been of great benefit to thousands of people and has also been responsible for the sudden and rapid growth of a vast industry, still no lives depend upon it. The most important thing in broadcasting is the radio market news in the mid-west and there the farmer depends upon it and still he is very puny compared to the importance of radio communication in the marine world, the trans-oceanic field and the



Even lighthouses in lonely spots are equipped with radio in this modern day.

(Continued on page 95)

What to Expect of Your Radio Set

By H. G. CISIN, M.E., Assoc. A.I.E.E.

AN old proverb states that he who expects little will not be disappointed. While this ought not to apply to radio, still there have been so many exaggerated claims made regarding radio receiving sets that the man who buys his first radio set usually expects performance far better than he actually gets.

The purchaser of a motor car knows in advance how fast the car can go, how many miles to the gallon, how much oil it will require, the probable life of the tires, and so forth. When he buys a radio set he cannot understand why he does not get similar hard and fast specifications. When he asks what distance the set will bring in, he is given what he thinks is an evasive answer. He asks how long this accessory will last, or that, and each time the dealer puts him off with the answer "that depends—". Finally he buys the set anyway, hoping for the best. When the new set arrives, the local stations are tuned in for a while and then a search is made for distant ones. If these are not immediately forthcoming there is a hue and cry. The set is condemned, the dealer is hastily summoned and there is a great amount of excitement.

Possibly you yourself have gone through this same experience. If not, and you are just purchasing your first set, there are a number of points which should be of particular interest to you. In addition to the radio set, the antenna installation and the batteries, there are a number of other factors upon which distance getting depends. For instance, in most cases it is practically impossible to get distance in the daytime. Moreover, on many evenings, atmospheric conditions are such as to preclude getting any distance at all. On the other hand certain cool, clear winter nights seem to give ideal reception and at such times it is often possible to get results far above the average.

Keep in mind the fact that even the best broadcasting stations are not always up to the mark in the quality of their broadcasting. Thus a station which ordinarily sends out clean-cut, sharply tuned, powerful waves, may at any time send out broadcasting lacking in power and not properly tuned. As a result the reception will not have the customary volume and the receiving set will not tune as sharply as usual. It is obvious that such a con-



The set is condemned, the dealer is hastily summoned and there is a great amount of excitement.

dition has nothing whatsoever to do with the receiving set. Certain broadcasting stations are unable to send out waves which will give satisfactory reception, due to lack of power, imperfections in transmitting equipment or other causes. Naturally you will never be able to receive these stations as perfectly as you get the more powerful ones. In some localities, reception is always poor and in fact, certain places are known as "dead spots," due to the difficulties in obtaining even fair radio reception. Fortunately, such "dead spots" are seldom encountered. You should have considerable patience with your new set, studying it carefully under varying conditions and not attempting to condemn its performance, at least in respect to distance, before three or four weeks. During this interval of time, if the set is used each night, you will discover another important fact—namely, that a radio set will yield results in proportion to your skill in operating it. In this re-

spect the radio set resembles a musical instrument. The more you practice with it the more you will be able to coax out of it. The tuning, on distant stations, is usually extremely sharp and the rheostats must be carefully manipulated to bring these stations in. Many sets will not bring in distant stations while the local stations are on, since they do not tune sharply enough. If your set is not selective, you will be able to get distance only after the local stations have signed off.

Do not expect to get more than you pay for. If one radio sells for \$60 and another one has a wide sale at \$210 you cannot expect to get the same results from the cheap set which you would get from the more expensive outfit. It is true that both sets may have the same number of tubes. They may even operate on exactly the same principles and utilize the same type of circuit. But in one case, only the finest materials are used and these are assembled carefully and tested

again and again. In the other case, the set is often made from the cheapest parts obtainable, put together in a slipshod way and not really tested at all. If you have picked up your set at a bargain counter there are many things you have no right to expect from it—especially distance reception while locals are on. If you have purchased an expensive set you have every right to expect the set to cut through the locals and bring in dis-

tations, including many distant ones, all received on the loud speaker. The purchaser's wife explained that the reason she had sent for the dealer was that the distant stations were neither as loud nor as clear as the locals, so she felt sure the set was defective in some way.

Radio manufacturers and dealers are often to blame for the lack of knowledge on the part of the public as to what a set should do. We are all familiar with the type of advertising which boldly claims "coast to coast" range under all conditions. Such advertising is misleading to say the least and should be toned down. Last winter, a Chicago set manufacturer had this brought home to him in a very striking way. He ran an advertisement in one of the Chicago newspapers with big headlines which read as follows: "Hear the Happiness Boys Every Friday Night on your —Set." It happened that on the next Friday night there was a great deal of static so that it was impossible to tune in any New York stations. On Saturday the complaints started to pour in. Letters and telephone calls by the score and every purchaser of that particular set who had expected to hear the Happiness Boys felt that he had been swindled.

In tuning in for distant stations make sure they are broadcasting and also be certain to take account of the difference of time in different sections of the country. It is impossible to make the set perform when there is no broadcasting on, as thousands of fans in the vicinity of New York discovered several months ago, when local broadcasting was discontinued for an entire evening because of an SOS call. According to International law, all broadcasting must be discontinued when an SOS or distress call is sent out by a ship. Many fans, who missed the announcement of the distress call, immediately came to the conclusion that there was some trouble in their sets, and as a result the dealers were kept busy answering telephone complaints.

If you allow the neighbor's fourteen-year-old boy to "improve" your set, do not be surprised if it suddenly stops working. There has been so much tinkering of this sort that many manufacturers have sealed up their sets and only guarantee them with the proviso that the seals remain unbroken.

If you use your set every evening, as you probably will, and other members of the family use it during the day, be prepared to have the storage battery recharged often. This is the battery which lights the filaments of the vacuum tubes. It is a simple matter to figure out just how long the battery will last. If you have an 80-

ampere hour battery, and a five-tube set using standard storage battery tubes, each tube draws one-quarter of an ampere or the five draw a total of $1\frac{1}{4}$ amperes. Dividing the $1\frac{1}{4}$ into 80 gives 64 hours as the time which will be taken to completely discharge the battery. This means that if the set is used on an average of 5 hours per day, the battery will be completely discharged in about 13 days. Using a 100-ampere hour battery under the same circumstances, the battery will be discharged in 80 hours or, if used 5 hours a day, in 16 days. However, your battery should never be allowed to become completely discharged as this shortens its life and otherwise spoils it. Hence in the case of an 80-ampere hour battery, used as above, it would be necessary to recharge in about one week, while in the case of the 100-ampere hour battery, recharging would be necessary in less than two weeks. The only correct way to determine exactly when the battery needs to be recharged is to use a hydrometer, testing at least as often as once a week. It is well to follow explicitly the instructions given by the battery manufacturer as to operation. Some batteries are fully charged when the hydrometer shows a reading of 1280, and manufacturer's directions usually recommend that battery be recharged before the specific gravity falls to 1150.

If your new battery loses its charge only a few days after the installation has been made, do not jump to the conclusion that the battery is defective. Batteries have to be "seasoned" before they will hold a charge properly. This usually means that the new battery will require recharging in from two to seven days. Thereafter it will hold its charge and only require recharging in proportion to its capacity and the



The neighbor's boy improves the radio set.

tance, subject of course to the exceptions mentioned above and with particular emphasis on the point that atmospheric conditions must be favorable.

The writer recalls one case where a man bought a high-grade high-priced radio set but made his own installation. He complained to the dealer that he was unable to get any distance whatsoever. An investigation revealed the fact that his aerial and lead-in were both grounded in a number of places and in fact it is doubtful if he would have been able to get even the local stations if not for the high sensitivity of the set. Another radio enthusiast tuned in five Chicago stations from his Long Island home on his new set the first night the set was installed. Several nights later he set the dials for Chicago again but was unable to get a whisper. He immediately telephoned the dealer who explained that as it happened to be Monday night, that night was silent night in Chicago!

Do not expect distant stations to come in clear as a bell, or just as good as the locals. There is bound to be more interference on the former than on the powerful local stations. A dealer was recently called out to service a set which had been in use about two weeks. He found a log sheet on which had been recorded at least forty



When going away on a week-end trip lock the door and switch off the radio set.

length of time it is used. In some cases, however, it is necessary to subject a new battery to two or three cycles of discharge and charge before it starts to function properly.

If you leave your storage battery

(known also as the "A" or filament lighting battery) standing for a long time, it may become greatly reduced in efficiency. During the process of discharge, a white crystal substance called lead sulphate is formed at both the positive and negative plates of the cell. When the battery is neglected for any considerable period of time, this sulphate gradually hardens and it becomes much more difficult for the charging current to reduce it. In this condition the battery is said to be "sulphated." As a general rule, if your battery becomes sulphated, this has happened through neglect on your part. To avoid this trouble, have a storage battery charged promptly as soon as it is discharged. Many people have a battery charged and then do not use it for a long time. When they finally decide to operate the set, they are much surprised to learn that the battery has lost most of its charge. This loss of capacity is due to local action within the battery.

From the above, it is obvious that the most effective method of doing away with battery trouble is to invest in a charger, and charge the battery regularly every week or oftener if necessary. If you buy a 2-ampere charger don't expect to charge a fully discharged 100-ampere hour battery in a hurry. Figure it out for yourself. It will probably be worth your while to pay the difference and buy a 5- or 10-ampere charger. It is well to remember that the oxygen and hydrogen liberated when a storage battery is being charged form an explosive mixture. For this reason, you should use especial care not to bring an open flame into the room where a battery is being charged and also not to cause a spark by short circuiting the connecting leads, as a dangerous explosion may result. In adding water to a battery to replace that which has evaporated, be sure to use distilled water.

When your set is installed, mark the date on each of your "B" batteries. These are the dry cells used to supply the proper voltage to the plates of the vacuum tubes. Of course, where a storage battery or "B" eliminating device is used to supply plate voltage this does not apply. Medium sized 45-volt batteries used on an average of three hours per night with a five-tube set should last three or four months. It should be noted that "B" batteries deteriorate even when not in use. In general, the smaller sizes deteriorate more rapidly than the larger sizes. If your batteries go dead in three or four weeks, they are probably old or defective and you should be entitled to replacement. Of course, there are many cases where "B" batteries may go dead through your own fault. In one instance, a woman placed a metal tray on top of the "B" batteries, thus short

circuiting them and rendering them worthless. In another instance, the filament switch was left on for over 24 hours, thus running down the "A" battery, shortening the life of the tubes and permanently weakening the "B" batteries. Neglect of this sort should not be blamed on the manufacturers or the dealers, although many people seem to think that a radio set is absolutely fool-proof.

of a small voltmeter. This test should be made about once a month or any time when the set is not operating properly. When a 45-volt "B" battery falls below 35 volts it should be discarded. Many people think they are being economical when they save their old "B" batteries and connect four or five run-down batteries in series, thus getting a total of the 90 volts required. This method usually results in noisy

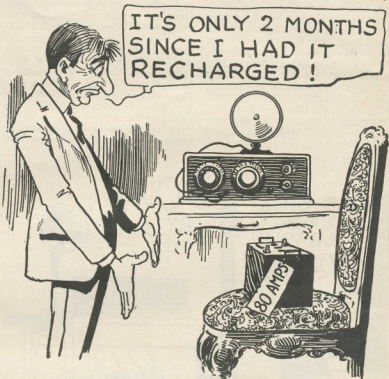

He can't understand why it stopped working.

Your set has a way of notifying you when its batteries are not up to the mark. When the "A" or storage battery starts to get weak you will notice a diminution in the volume of the local stations and you will probably be unable to get any distant stations at all. Further weakening of the "A" battery will result in a sudden cessation of reception. Sometimes the music or speech fades out and stops. Thereafter if the switch is turned off and then turned on a little later, sounds can again be detected, and these also die out rapidly. If the rheostats must be turned on full in order to get sufficient volume, this is a very good sign that the "A" battery needs recharging.

Weak "B" batteries often cause noisy reception and they also may be responsible for reduced volume. Many good loud speakers will not operate correctly unless the "B" battery voltage is correct. Such speakers often rattle when the voltage of the "B" battery is too low. The best way to test "B" battery voltage is by means

reception and it is quite usual for a poor battery when used with good ones to cause the latter to run down rapidly also.

If you treat your tubes with consideration, they should last a long time. If they are handled carelessly you may have to purchase new ones in a few weeks. The rheostats are put on your set for definite purposes. One of the most important of these is to enable you to cut down the filament current. The rheostat should be turned on slowly. The tube filament is delicate and when cold it has a low resistance. If the current is applied at full voltage to the cold filament, the tube may burn out in a flash before it has had a chance to warm up. The rheostat cuts down the voltage and thus enables the filament to warm up before full voltage is applied. One per cent. more voltage than the tube is rated at can cut down the life of the tube 25 per cent., and just a little more cuts the life of the tube in half.

It should be remembered that a tube

may light and still not operate. A tube in this condition is said to fail to oscillate. Such a tube is defective and should be replaced without question, by the dealer.

If you slam down the cover of your set and jar the tubes badly you may ruin them. If you have been obliged to disconnect the set from the batteries in order to change its location or for any other reason, do not connect it and turn on the switch as you may in this way burn out all the tubes if you have made a wrong connection. After the wires have been connected and you have carefully checked over each connection twist the tubes in their sockets so that they no longer make contact. Then put back one tube so that this makes contact and turn on the switch, using the single tube as a final test. Proceeding in this way you eliminate the possibility of burning out all your tubes at once.

than the others. This test should be made with the set operating and with the volume as low as possible. The better the tube, the louder and clearer will be the reception. Many sets are marked for a detector voltage of 45 volts. It should be understood that this is not essentially a fixed requirement of the set but varies with each particular detector tube. The soft detector tubes, formerly used, usually gave best results with a plate voltage around 22½ volts. A good many of the standard tubes, when used as detectors, operate best at 45 volts on the plate. Many tubes, however, show a decided improvement when a plate voltage either higher or in some cases lower, than 45 is used. This is a condition that can only be determined by test, while broadcasting is being received on the set.

If for any reason, a tube must be replaced, do not assume that any tube

obtaining tubes which are not available to most of us. However, a selection from half a dozen tubes will often greatly improve results. Matching of tubes is especially necessary in sets which use automatic filament control.

The loud speaker should be given the same care as any other part of the set. If it is dropped, it will probably be thrown out of adjustment and it may be permanently ruined. Where an adjustment is provided for bringing the diaphragm and the magnets closer together, great care should be taken not to tighten this adjustment too much as this may result in bending the diaphragm and thereafter reproduction will be very poor. In such a case, the only remedy is to obtain a new diaphragm. Many cone speakers are provided with a thumb screw at the point where the rod connects to the parchment. This is not an adjustment of the ordinary type, but is for use only in case atmospheric conditions alter the tension of the diaphragm. If the tension of the diaphragm is too great, due to a change in the temperature or to other causes, it is simply necessary to loosen the thumb screw, thus allowing the diaphragm to assume a normal tension, and then to tighten the screw again. The terminals of the loud speaker should be reversed at the plug and the speaker tested and the reproduction should be compared with the terminals in the original position. Many loud speakers give greatly improved results by thus reversing the terminals. Very annoying trouble will sometimes result from unexpected causes. In a case where a phonograph unit was used in connection with a Victrola, the set suddenly stopped working, even though the tubes were properly lit and all the batteries were in perfect condition. A thorough test revealed the fact that the cover of the phonograph had cut through the connecting cord due to the fact that each time the cover was closed the cord was under pressure. After a while the insulation was removed from both wires leading to the unit and a short circuit resulted, thus rendering the set inoperative.

This article would not be complete without a few words about the various squeals and noises which are heard from time to time but which have nothing to do with the set itself. First of all, there is static to contend with. This is a crackling noise which often comes in, in a series of crashes. While various static eliminators have appeared on the market, this problem seems to be one which is still to be solved. However, static does not interfere with the local broadcasting of powerful stations and moreover it is not of frequent occurrence except in the summer months. Another ex-

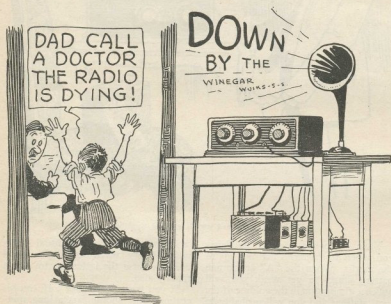

Your set has a way of notifying you when its batteries are not up to the mark.

In putting tubes back into their sockets, be sure that the prongs are making contact. Sometimes the socket prongs become bent. It is then necessary to remove the tube and pull the prongs upward with the finger. Tubes may be of exactly the same type and apparently identical in every way and still will vary considerably in their characteristics. This especially applies to the tube used as the detector tube. Most sets are now constructed to use the same type of tube for a detector as that used for amplifying. By changing the tubes around and trying each one in the detector socket, you will usually be able to find one tube which will give much better results

of the same type can be substituted. In many sets, the tubes are carefully matched so as to have the same operating characteristics and unless the new tube is matched to the others, poor results are likely to follow. It may be necessary to try out a number of tubes before the right one is found. The writer recalls an acquaintance in St. Louis who tested out 100 tubes in order to properly match eight tubes for his super-heterodyne. This man claimed that the remarkable results which he obtained from his set were largely due to the perfect matching of the tubes. Inasmuch as he was the manager of a large radio and electrical jobbing concern, he had facilities for

traneous noise which you will soon learn to distinguish is that of the code transmitter. Inasmuch as both ship and land stations are now confined to higher wave-lengths than those used in broadcasting, this cause of interference is rapidly disappearing. Sometimes in tuning in a station, a steady whistle, similar to the whistle on the itinerant peanut stand, is heard. This does not change in pitch and cannot be tuned out. It is probably caused by the action of another broadcasting station operating upon a wave-length close enough to the first station to cause this trouble. The technical name for this type of interference is called "heterodyning." What actually happens in this case is that the frequencies of the waves being sent out by the two stations overlap, differing by just enough to produce a new wave or note, called a "beat" note, which has an audible frequency.

This trouble is seldom serious and is noticed more frequently on the lower wave-lengths, which are more crowded. Many receiving sets will set up a steady singing hum if the loud speaker is placed on top of the set. To stop this trouble it is simply necessary to move the speaker away from the set until a position is reached where the hum ceases. In certain instances a bell-like tone may be due to a detector tube which vibrates at an audible frequency whenever the set is jarred and which then continues to vibrate for some time, producing this particular note. Such a tube is said to have a "microphonic" action. The remedy is to use one of the other tubes as the detector.

Some of the most annoying noises are due to the improper tuning of a regenerative set in the neighborhood of a receiver. "Dial twisting"

on the part of your inconsiderate neighbor who owns a regenerative set, may cause most objectionable squeals to come out of your set. The operation of elevators may cause clicks in a nearby set and some sensitive sets are affected by being located near a telephone. The operation of an X-ray machine or even a vacuum cleaner will often cause a steady hum in the receiving set. An aerial running parallel to a nearby trolley wire or to a wire carrying high-tension current will usually cause serious interference.

From the foregoing, it would appear that the perfect operation of your radio set is not as simple a matter as many people believe. Nevertheless, if you give your set a reasonable amount of care and attention, even a great deal less than you give your car, it will repay you with long continued and satisfactory service.

The How and Why of Radio Code

(Continued from page 90)

sengers off Delaware Breakwater, he made a prayer of thanks for the great invention that safeguarded the lives of those who travel the sea and then *CODE* interference assumed a far different aspect in his eyes.

The writer has seen "intelligent" men and women in a broadcasting station studio red with anger because an SOS call compelled the discontinuing of broadcasting, leaving the air free for messages relating to the call. International law provides for the secession of all radio activity other than that relating directly to the distress call and that is why sometimes you tune in on your receiver and hear nothing on the broadcast bands. At such times, if you should tune to the highest point on your dials you would hear plenty of code signals and if anyone is around who knows the code an interesting—far more interesting than music—program await you with its true-life drama.

The interfering waves noticed mostly from ships on regular broadcast receivers come from the 600-meter band used for calling and general brief communication and occasionally, when the sending station is too near, from 700 meters, where messages are exchanged. Sometimes, although it is rare, the interference will be noticed on 800 meters, with forced oscillations on the lower waves and harmonics. Here the wave is used by ships to get their position. This is a radio compass wave and it is a very important wave to the navigator, nowadays, as statistics have shown that the radio compass stations of the world are daily

saving millions of dollars to marine traffic interests as time savers and serve to avoid many marine accidents.

Another bugbear is the radio amateur on 200 meters. The government has advised all amateurs to discontinue the use of spark transmitters. However, slight interference is sometimes noticed from amateurs who use alternating current on the plates of sending tubes or use modulated buzzers which occasionally interfere with the listener, if he is too close to the amateur and is listening on the lower wave bands from 300 meters down. However, in the past year 90% of the interference from amateurs on broadcast bands has been eliminated and the primary source of annoyance centers on foreign ships who still use the 450-meter ship band for communication although in this country that wave band is forbidden and our government is fighting the use of 300 and 450 meters which, up to recent years, were used by ships and shore stations to avoid the 600-meter jam. The government, however, have substituted 700 meters to take the place of these two, so in the final analysis the world is better off as this eliminates interference with broadcast listeners on the broadcast bands.

There are many of our readers who have expressed a desire to know more of the ship radios and the men who operate them. These operators make an opening for a story that is wonderful and filled with romance and adventure and in a later issue we will tell you the story of their lives and duties.

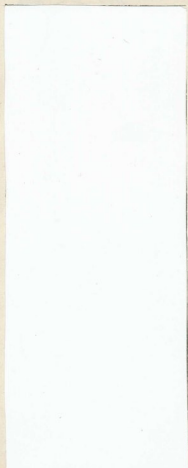

The telegraphic codes used in radio.

Experiments with Transmitter Buttons

By JOSEPH H. KRAUS*

ONE of the most interesting little pieces of electrical apparatus is what is known as a transmitter button. This particular device lends itself admirably for use in radio and electrical circuits, and in view of the fact that many do not realize to what

either horizontal or vertical. It is so small that it can be readily concealed in any of a dozen or more places, and thus serves as an admirable detectophone. For instance, it can be placed in a watch case; an old watch case is used and a tiny hole drilled in the

transmission is possible. If a tiny hole is drilled into the side of a glass and a person should talk towards the glass, as indicated at Fig. 5, it will be found that speech can easily be transmitted in this manner. This makes a very nice little experiment for electrical clubs.

Music from a phonograph can be transmitted the hook-up illustrated in Fig. 6 wherein a small hole is drilled in the side of the tone arm of the phonograph, and the screw of the transmitter button is inserted in that hole. There are several other means for doing this perhaps a little more efficiently than indicated here, and these will be described elsewhere in this article.

These transmitter buttons can be used as detectophones for conveying speech to detectives or operatives stationed elsewhere in a hotel or in the house by using the methods illustrated in Figs. 7 and 8. In the former case a microphone button is mounted in the back of the picture. The tiny screw on the surface of the picture is not noticeable to the casual observer and any plot could easily be detected. It is advisable, however, in placing mi-

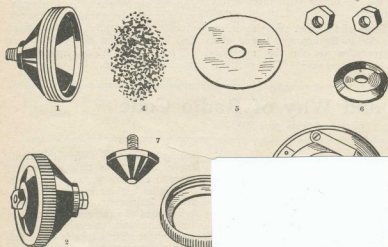

FIG. 1

important uses such a button can be put, it is advisable to cover the use of this little-transmitter in its various fields so that one will easily see how each and every one of the systems are applicable to radio uses. In Fig. 1 a transmitter button has been taken apart so as to show its internal construction. Here the numeral 1 indicates a small brass cup approximately three-quarters of an inch in diameter. This cup is very nearly filled with carbon grains shown at 4. After the grains are placed into the cup, the small mica diaphragm 5 fitted with the wedge-shaped electrode 7 at the bottom, and the locking screw 6 on top, is placed into the cup and then the diaphragm is locked in place with screw 3. The assembled view of the transmitter button is also shown in the photo, and its method of attachment to an ordinary telephone transmitter is likewise indicated. In Fig. 2 we see a cross section view taken through the transmitter button showing the location of the various parts.

The remarkable thing about this transmitter button is that it can be made to transmit in any position,

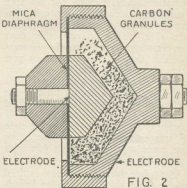

FIG. 2

crophones in suspected positions, to locate several of them in the same room and use different sets of wires for each, running each pair out of the room through different exits. In event then that one of these detectophones is discovered, there are still two or three of them in the room which remain to be discovered. Most criminals will assume that when they have once destroyed one detectophone that they are free from further interference on the part of this silent watchman. If

several detectophones are placed in the room a complete transcription can readily be taken by the reporting stenographer.

PHONOGRAPH MUSIC AT A DISTANCE

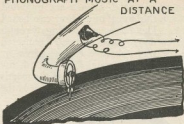

FIG. 6

For those hard of hearing such a device would be of particular benefit, as the church could be fitted with several sets of ear phones and the speech, greatly amplified, would be impressed upon the diaphragm of the ear, and

AS A DETECTOPHONE ON PICTURE



FIG 7

thus transmitted to the inner ear and brain in a much stronger manner than if the voice were merely heard in the usual manner. For transmitting the sound of a violin to persons hard of hearing and also for the production of various stage effects, the microphone

MATCH BOX DETECTOPHONE



FIG. 8

button can be screwed fast to the body of the violin, or preferably to the bridge, as this latter position in no way damages a valuable instrument. In this manner all the tones of the

TALKING THROUGH CHEST



FIG 9

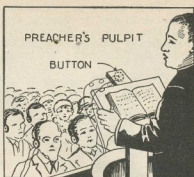

FIG. 10

violin are faithfully reproduced in the distant receiver, or they may be amplified by means of a regular vacuum tube amplifier, such as you have in your radio set, and then transmitted to the crowds in the dance hall. Several of these microphone buttons attached to the various instruments in the band and all connected to a good amplifier,

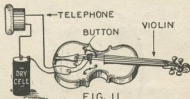

FIG. 11

could be made to fill the largest hall with music. The band itself need not necessarily be very large. This particular hook-up is illustrated in Fig. 11.

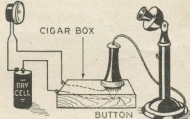

FIG. 12

Fig. 12 shows how the sounds from a telephone receiver can be made to travel to a distant receiver. Here the microphone button is mounted inside

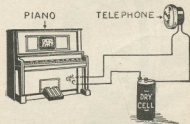

FIG. 13

of a cigar box and the receiver is then placed right on top of the position of the button.

WATCHCASE

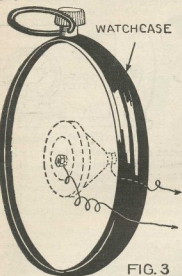

FIG. 3

In event that a minister should have several sick members belonging to his parish who are unable to attend Sun-

DIAPHRAGM WITH BUTTON HELD TO THROAT

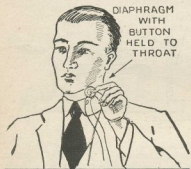

FIG. 4

day services, it is possible for him to place one of these small microphone buttons in front of him in the pulpit. In this way he would be able to trans-

FIG 5

mit the complete text of his sermon to any of those who care to listen and who are interested enough in going to the expense of stringing a few wires from the point at which the talk takes place to their homes.

Fig. 13 shows how the microphone button can be used to transmit the sound of a piano to a distant room. The button is preferably fastened to the sounding board in a piano, but it

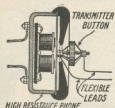

FIG. 14

may be fastened to any convenient place on the piano to accomplish this work. This is of value where there may be a sick patient in a home on the second or third floor far remote from the piano, and who would like to listen to any music played on the piano by some of his friends.

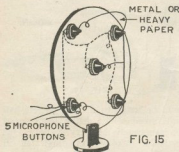

FIG. 15

In Fig. 14 we show how radio music can be transmitted to distant points and incidentally amplified at the same time. Here the microphone button is soldered to the diaphragm of the receiver as indicated, and then the leads connected in series with several dry cells and a low resistance phone.

For experimenters desiring to get greater sensitivity and volume for either radiophone transmitting stations or for ordinary phone transmission, the particular system illustrated in Fig.



FIG. 16

15 will be found highly suitable. Here five or six microphones are mounted upon a thin metal or a heavy cardboard disk. The screws projecting through the cardboard are then all connected by means of flexible copper wires, or in event that a metal disk is used, the metal disk itself will serve as the means for making connections between the

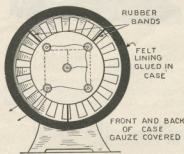

FIG. 17

screws and one thin lead soldered to the disk will suffice. In order to make a more classy job of the device, an old molded variometer makes a fine microphone case. The wire is removed from the variometer and then the case is packed with felt lining

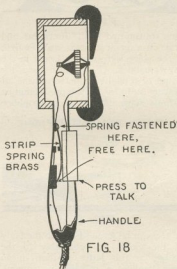

FIG. 18

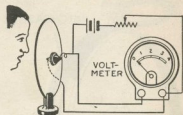

FIG. 19

means of three rubber bands, as indicated. The front and back of the case are then covered with fine silk gauze. This makes a very presentable instrument which looks very much like those microphones used in our broadcasting stations.

In Fig. 18 we show the construction of a hand microphone for transmitting sets or for inter-departmental telephone circuits. A very simple circuit closer is mounted in the handle of the microphone which in this particular case is an ordinary piece of wood hollowed out to receive the switch and the wires. This wooden handle is then

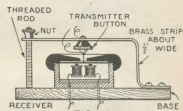

FIG. 21

fastened to the rubber case of a telephone receiver. The coils and magnets in the telephone receiver are removed, a small hole is drilled or punched into the diaphragm, and the transmitter button is fastened as indicated in the diagram.

In making transmitters using multiple transmitter buttons, as illustrated in Fig. 15, 16 and 17, it is frequently desirable to use buttons which have a resistance almost identical. For this purpose the method outlined in Fig.

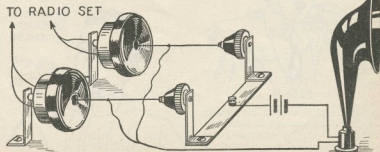

FIG. 20

19 will be found quite satisfactory. An ordinary voltmeter is placed across the terminals of the microphone and then the batteries and rheostat are connected in parallel with the voltmeter. By measuring the voltage drop across the microphone when a certain sound is uttered, and making three tests to obtain an average, it is possible to de-

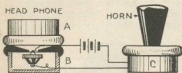

FIG. 22

termine exactly what the voltage drop across the microphone will be. One transmitter button is then substituted for another and the same procedure followed. When five transmitter but-

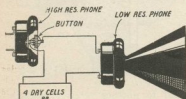

FIG. 23

toms have been tested, and they all give the same voltage drop, they may be used in a sensitive transmitter without fear that one of the buttons will heat

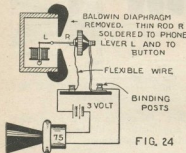

FIG. 24

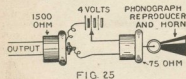

FIG. 25

more than the other and produce a possible frying noise.

Amplifying Radio Music

Any of the microphones described in the first part of this article may be used for amplifying radio music when the telephone receivers are placed in close proximity to the transmitter buttons and when the batteries and one or more low resistance receivers are put in series with the transmitter buttons, but there are several ways of improving even these results, and they will be described now.

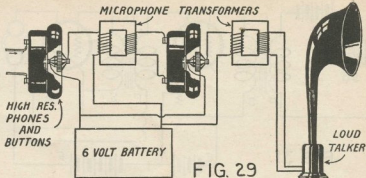

FIG. 29

In Fig. 20 we show how two radio receivers are fastened to a piece of wood. These receivers are naturally connected to the receiving set which

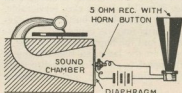

FIG. 26

in this case we may assume to be an ordinary one-tube receiver not giving very much power. A thin steel wire is soldered to the center of the diaphragm of both the receivers, care being taken that the wires are not bent during the soldering process. These wires then lead to the transmitter buttons and are fastened to them as illustrated. The other side of the buttons are secured to a brass plate, or a couple of small brass angles which

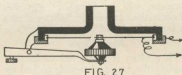

FIG. 27

should be adjustable so that proper regulation may be made. Two flexible leads then connect with the steel wires, as indicated, and a wire is fastened to the two brackets. The wires are connected in series with the battery and a low resistance phone, which is

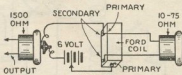

FIG. 28

mounted in the base of the horn, as the illustration clearly shows.

Another method of fastening a transmitter button to a receiver is illustrated in the diagram in Fig. 21.

Here the transmitter button is mounted on a brass strip which is bent so that the center of the button will rest upon the diaphragm of a telephone receiver fixed to the base. A threaded rod and nut regulate the pressure of the button against the diaphragm. In event that it is not desired to make any changes to a pair of receivers, the transmitter button can be fastened in the shell of an old receiver, B in Fig. 22, and the head phone may be rested

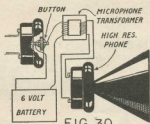

FIG. 30

upon the shell. As indicated, or as previously shown, the hook-up in Fig. 23 may be employed.

In event that the owner of the receiving set has a Baldwin receiver, a microphone transmitter button is fastened to it in the following manner: The diaphragm of the Baldwin receiver is first removed and a thin rod is soldered to the lever, as indicated in

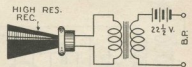

FIG. 30-A

Fig. 24. The transmitter button is then soldered to the rod as shown.

Another way of making a loud speaker from an ordinary one-tube receiving set is illustrated in Fig. 25. In event that you have a phonograph at home, you merely employ the hook-up there illustrated and then place the reproducer of your phonograph on the receiver which should be placed in a suitable position on the turntable. Inasmuch as the movement of the diaphragm of the seventy-five-ohm re-

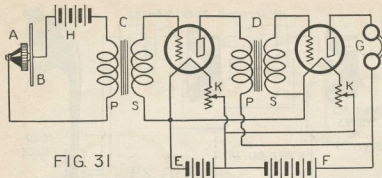

FIG. 31

ceiver is an up and down one, the reproducer of the phonograph should be turned as it would be for "hill and dale" records. A tiny drop of solder

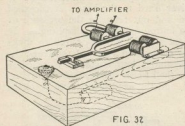

FIG. 32

could be dropped upon the diaphragm of the seventy-five-ohm receiver, and a small nick should be placed into the center of the solder for receiving the needle of the phonograph reproducer.

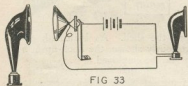

FIG. 33

In Fig. 26 we show how the music from a phonograph can be picked up and amplified by means of the trans-

mitter button. In event that an outdoor fete is to take place, it will frequently be found that the sound of a phonograph is too weak to carry. For this reason the hook-up illustrated in Fig. 26 will be found very serviceable. Several microphone buttons and several horns may be connected as illustrated, and the horns should be placed about on the lawn, so that the music will appear to come from all directions at one time. Even one transmitter

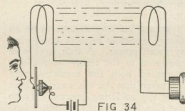

FIG. 34

button would serve the purpose if the music were amplified by means of a standard amplifier. The best method of transmitting phonographic music, however, will be found in Fig. 27, wherein the transmitter button forms an integral part of the reproducer.

Amplifiers

Very often it is desired to further amplify the music or sounds picked up

by a transmitter button. For this reason microphonic transformers or as they are better known, modulation transformers, are employed. In Fig. 29 this instrument and the circuit for its use, is illustrated. Here the incoming radio signals are made to operate the microphone fastened to the receiver. The current which the microphone passes then goes through the primary of the microphone transformer, the secondary of which is con-

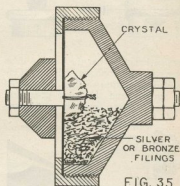

FIG. 35

nected to another receiver similarly fitted with another transmitter button. The output of the second microphone transformer is then connected to a loud

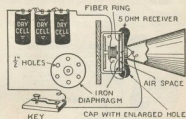

FIG. 36

talker. Of course several more stages of amplification could be connected together in this manner. It is obvious

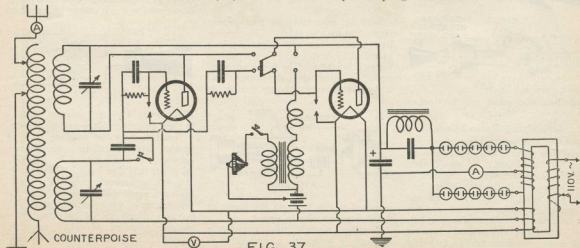

FIG. 37

TRANSMITTER BUTTONS

"Amplifier Units"

BUTTON
One-half
Actual Size



Here's a marvel of Engineering design—a practical miniature transmitter, used by thousands of radio fans and experimenters for amplification purposes.

SPECIALLY PRICED

85¢ PER UNIT
WHILE THEY LAST
OR TWO FOR \$1.50

THIS is a most novel unit, having hundreds of uses. Every amateur should have two or three of these amplifiers in his laboratory.

With each unit is mailed a four-page instruction pamphlet. It shows how to use these units.

Our supply is limited, avoid disappointment by ordering today. The coupon below is for your special convenience—just fill in your name and address, mark in the number of units you desire, enclose the necessary amount and we will ship them to you at once postpaid.

COUPON

THE PRESS GUILD
66 West Broadway, New York, N. Y.

Enclosed find ^{85¢}\$1.50 for which send me postpaid ^{one}two amplifier units as advertised.

Name

Address

City, State

Among the many hundreds of interesting uses are the following everyday applications —

LOUD SPEAKERS
SPEECH AMPLIFIERS
TELEPHONE TRANSMITTERS
DETECTOPHONES
Etc., Etc.

that the installation should be placed in a box of a sound-proof nature, so that extraneous noises will not effect the microphones. If the box is sound-proof no howl will be experienced. If a howl is noted, it is plain to see that the output of the loud speaker is effecting the microphones, and thus the characteristic audio frequency sound will constantly be heard.

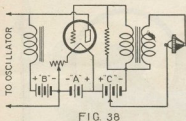

FIG. 38

The use of a Ford coil as a transformer is illustrated in Fig. 28. A Ford coil, if you have an old one, which is of no practical use, but is not burned out, will serve the same purpose as a modulation transformer, possibly not as efficiently as the aforementioned device, but will certainly give the results and is worth experimenting with. The schematic hook-up for either of the two systems is illustrated in Figs. 29 and 30A.

A diagram for using but one stage of amplification through transformers is illustrated in Fig. 30. For the better class of work, however, it is desirable to use a standard vacuum tube amplifier, as illustrated in Fig. 31. Here the microphone button is placed in series with the primary of a modulation transformer, and in series with several dry cells or flashlight batteries. The secondary of the modulation transformer then connects to the grid and filament the same as it would in a standard vacuum tube amplifying circuit. The music from the output is, of course, very loud.

A very splendid oscillator is illustrated in Fig. 32. Here a tuning fork of standard frequency is mounted on a suitable holder in a cigar box. Two low resistance coils about five to seventy-five ohms, are then placed under one prong of the tuning fork. These are connected in series with a transmitter button fastened in the cigar box which serves as a base for mounting the tuning fork. The batteries may be concealed in the cigar box. Thus when the tuning fork is struck, it will continue to vibrate as long as the current is applied to the microphone. To use this as an oscillator, a pair of magnets from a receiver and the permanent magnets are mounted near the other vibrating prong. The current constantly being changed by means of the vibrating bar of steel produces a standard frequency, which when amplified can be used for making radio

measurements of different kinds. Fig. 33 shows how a transmitter button may be fastened to a cone placed in front of a loud speaker, so as to transmit the sounds of the loud speaker to a distant loud speaker.

In Fig. 34 we show how experiments with an induction telephone may be made. Here a microphone button is connected in series with a coil of wire and the batteries. Several feet away another coil of wire is mounted parallel to the first coil and this is connected to a low resistance receiver.

It may be interesting to note that the writer used this same principle in a magical act some years ago. A coil

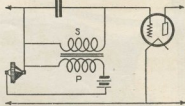

FIG. 39

of wire was wound into a carpet and a transmitter placed in series with this coil of wire. Another coil of wire was wrapped around the waist of a supposed medium who walked into the room and sat down. A tiny receiver fitted into the ear of the medium and was concealed by a Hindu head-dress. The assistant in back of the stage then

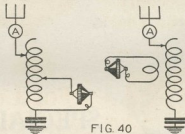

FIG. 40

telephoned the questions written on slips of paper, which were heard in the telephone receiver and answered by the medium. The medium naturally could move about and hear the questions as she was walking. She must not get too far away from the coil of wire concealed beneath the carpet. For better results the voice transmitted to the coils was amplified by means of a vacuum tube amplifier in a circuit similar to that illustrated in Fig. 31, except that the coil of wire was placed in the position now occupied by the phones in that diagram.

Fig. 35 shows how the transmitter button can be used for making a "crystallo" detector. This is a crystal detector which is constantly adjustable. A regular galena or silicon crystal is mounted at the diaphragm end of the shell and the same is half filled with silver filings. Rotating the

shell picks out sensitive spots in the receiver. Copper filings also make very good contact points as do phosphor bronze filings.

Fig. 36 shows a method of making a code practice device. An audio frequency howl is produced which will enable the instructor to teach an entire classroom the radio code. Sometimes the key, instead of interrupting the circuit, merely shunts a small portion of the current passing through the transmitter button, and for this purpose the key would have to be placed directly across the transmitter button and in series with a small resistance.

Fig. 37 shows how the transmitter button may be adapted to the Meissner circuit. Fig. 38 shows how it may be used in Heising modulation. Fig. 39 indicates its adaptation to the variation of grid voltage of the oscillator tube, and Fig. 40 how the transmitter button may be hooked up to modulate the output current. These last four figures indicate the use of transmitter buttons in vacuum tube transmitters. Fig. 41 shows a transmitter button used as a grid leak in a regenerative circuit.

Very often the experimenter would like to build his own modulation or input transformer. Considerable experimenting may be done along this line. Cover a straight iron core about 5 in. long and composed of a bundle of No. 20 iron wire about 1/2 in. thick, with a thin layer of tape or paper. Upon this wind approximately four layers of No. 22 wire along a space of 4 1/2 in. This is the primary of the transformer. The secondary should be composed of about twenty-five layers of No. 30 enamel covered wire. Each layer may be insulated from its preceding layer

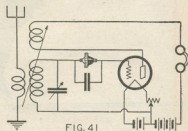

FIG. 41

by thin wax paper, or the wire may be wound upon the iron core without insulating the individual layers. The beginning and end of the wiring should be soldered to small flexible leads, because the No. 30 wire breaks quite easily.

Modulation transformers are the amplifying transformers for circuits using the microphone buttons for the various stages. These particular transformers should not be used wherever a vacuum tube is employed as the amplifying means, but regular audio-frequency transformers, such as used in any radio set, should be here inserted.

No matter what circuit— Far, Far Better Results with

KARAS

Orthometric Condensers and Harmonik Transformers

KARAS instruments have been tested and recommended by leading technical editors for use in all types of sets from the most elaborate supers to the simplest low loss 3-tube receivers. The most exacting home set builders, the country over, demand Karas Transformers and Condensers—and will use nothing else. Nothing can take the place of these scientifically designed, precision instruments. Use them in your next set—or improve your present set by installing them. It's easy to do—the results will be worth many times the cost.

**Spreads Stations Evenly
Over the Dial**
—No Crowding
Whatever!

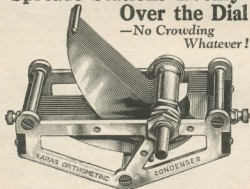

The Karas Orthometric Condenser positively separates all adjoining wavelengths by EQUAL distances on the dial—giving you full benefit of the 10 Kilocycle frequency separation fixed by the government. Ordinary condensers jam 70 of the 100 Government allotted wavelengths into the first 30 points on the dial—even straight-line-wavelength condensers crowd 57 of them below 30. But with Karas Orthometrics, each point on the dial corresponds to one of the 100 allotted wavelengths. The result is marvelous simplicity in tuning—and better, clearer reception—all side bands without interference.

Brings in KDKA at 53

Not at 17—or 25, but at 53 where it belongs, leaving lots of room for the 52 wavelengths that must come in below it. The Karas Orthometric is a "precision job"—entirely of brass. Every joint soldered. Plates patent-levelled and securely bridged.

If your dealer is out of Karas Instruments

Order Direct on This Coupon

Most good dealers everywhere sell Karas parts. If your dealer happens to be one who doesn't, we will supply you direct at no trouble on your part—on our 30-day money back guarantee. Just fill in and mail this coupon at once. Send no money. You can pay the postman on delivery.

KARAS ELECTRIC CO., 4061 North Rockwell Street
CHICAGO, ILLINOIS

For more than 30 years makers of PRECISION Electrical Apparatus



For Long Distance with Big Volume and Keen Musical Quality

Karas Harmoniks deliver perfect music with loads of volume from stations one to two thousand miles distant. DX broadcasting becomes really enjoyable. "Fishing" for distant stations is only a matter of finding programs you want to hear—not straining to catch only the bare announcement and making up a list of call letters.

Even from far away points, Karas Harmoniks bring out full, round musical tones. All the vital harmonics and rich overtones are fully retained. Low bass notes pour forth, rich, sweet, sonorous. If you want music like this, you must have Karas Harmoniks in your set. Get a pair TODAY!

Karas Electric Co.,
4061 N. Rockwell St., Chicago

Please ship me the instruments checked below. I will pay the postman prices listed, plus postage upon delivery. It is understood that I have the privilege of returning these goods, for full refund, within 30 days, if they do not prove entirely satisfactory.

..... Karas Harmonik Audio Transformers. (\$7.00 each)

..... Karas Orthometric Condensers: 512.....
[23 plate \$7 ea.; 17 plate \$6.75 ea.; 11 plate \$6.50]

Name

Address

If you send cash with order, we'll send package postpaid

How Many Radio Circuits Are There?

By SYLVAN HARRIS

In spite of the fact that there have been published here, there and everywhere, a multitude of radio circuits, under as many different high-sounding names, the fact remains that there are very few fundamentally different circuits. In this article I will endeavor

ment. No sources of voltage have been shown on this fundamental diagram for they may be applied in various ways, as shall be explained. The only battery shown is that which is used for lighting the filament, which is always applied in the same manner, and to tell the truth, this application is not subject to much variation.

Fundamentally, the action of the electron tube is much the same, no matter whence or how the various electromotive forces which operate it are derived. For instance, in figure 2 we have shown several methods of

a high frequency electromotive force to apply to the input. Where or how we obtain it is a secondary consideration, as far as the operation of the tube is concerned; this does not affect the operation of the tube fundamentally, although it may affect the method of tuning the circuits considerably.

In A of figure 2 we have the most generally used method, viz., the input voltage to the tube is obtained from the potential difference established across the terminals of the variable condenser by the high frequency current flowing in the tuned circuit. This tuned circuit has an electromotive force induced in it by being coupled to another circuit carrying a high frequency current, as for instance the antenna circuit of a radio receiver. In B of figure 2, we have what is commonly known as impedance coupling, that is, the potential difference to be applied to the input of the tube is that which is set up across the terminals of an inductance or impedance coil, which may or may not have an iron core, depending upon whether it is to be used for amplifying high or low frequency voltages. The ends of this impedance coil are connected to another circuit carrying a high frequency current, just as in the preceding case; this other circuit may be the output of a preceding amplifier tube, or, again, the antenna circuit.

In C of figure 2 we have shown what is called resistance coupling; here the input voltage is obtained as the difference of potential between the terminals of the resistance indicated, in just the same manner as the potential difference is obtained in the case of the impedance coupled tube.

There is one remaining system,

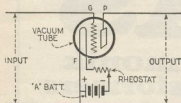

FIG. 1
Elementary circuit of a vacuum tube.

to outline these fundamental circuits for my readers, and will show how these are combined in various ways to produce the many "dynes," "plexes" and what not.

The fundamental circuit of the three-electrode vacuum tube is shown in figure 1. No matter what kind of circuit is used in the radio receiver,

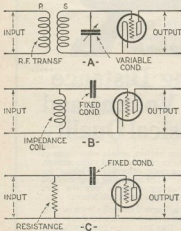

FIG. 2
Three different methods of applying input voltage to the vacuum tube.

and no matter what name may happen to be given it, this fundamental circuit still forms the basis of the receiver.

In this circuit the input of the tube is, as marked on the illustration, between the grid and filament, and the output is between the plate and fila-

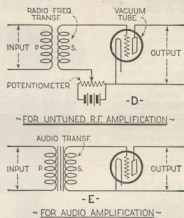

FIG. 3
Additional methods of applying input voltage.

applying the input voltage to the electron tube, which is to act in the capacity of an amplifier or a detector of the high frequency oscillations which constitute the radio signals. Three methods of obtaining the high frequency voltage to apply to the input of the tube are shown. Even

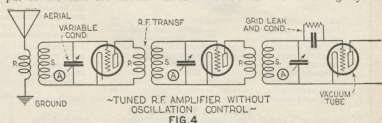

FIG. 4
The above circuit must be made inefficient in order to insure stability.

these three do not constitute all the methods that are in use, but are only the most generally used methods. The main thing to remember is that we must obtain somehow, somewhere,

shown in figure 3, which is practically the same in effect as that of A, figure 2. This is the untuned transformer system. The tuned transformer system (A of figure 2) is tuned by the

condenser indicated. In the untuned system this transformer may or may not have an iron core, depending upon whether it is required to amplify high or low frequency voltages. It is generally used with an iron core for amplifying audio frequency voltages, but the untuned transformer, without an iron core, has often been used for amplifying radio frequency voltages, in which case a potentiometer is used to control the tendency toward self-oscillation. In figures 4, 5 and 6 we have the complete circuit diagrams of high frequency amplifiers using these various systems. In each of the stages in each of the diagrams a capital letter indicates the fundamental upon which the circuit is based, corresponding to the letters used to identify the systems of figures 2 and 3.

In figure 4 we have the tuned r. f. amplifier, without any provision made for controlling the tendency toward self-oscillation. Generally stability is secured in this system by making it so inefficient that it cannot oscillate.

stage which is required to be tuned, so as to be able to tune stations in or out. The tendency to oscillate is likewise controlled by means of a potentiometer.

These are the three main systems for amplifying high frequency volt-

We will not discuss this principle here as it is rather complicated. The circuit diagrams are presented so that my reader will be able to identify them.

In figures 9, 10 and 11 we have three systems of amplifying audio fre-

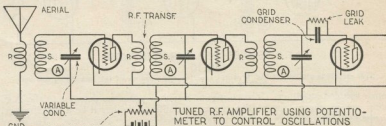

This circuit is more efficient than one shown in Fig. 4.

FIG. 5

quency voltages. In figure 9 we have the ordinary transformer coupled amplifier, which, of course, is untuned. The detector tube is shown connected to the amplifier in all three illustrations, as this is generally found to be the case in the usual radio receiver. In figure 10 is shown an impedance coupled amplifier connected to the detector. It will be seen that this does not differ essentially from the case of the transformer coupled amplifier, for in this case, the one winding of the transformer acts as both primary and secondary winding. The condenser shown connected to the grids of the two last tubes is for the purpose of blocking off from the grids the high "B" battery voltage which would find its way around through the winding

ages, but there are often added to these various other things which may or may not facilitate the operation and control of the receiver. Often these adjuncts to the receiver are useless, and are merely added to it so as

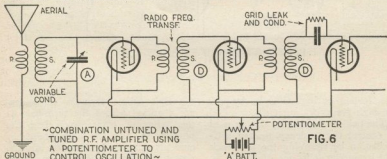
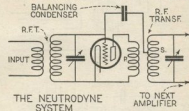

FIG. 6

The first stage must be tuned to allow stations to be tuned in or out.

In figure 5 we have the same tuned system, but this time we have added a potentiometer, by means of which the system can be made to oscillate or not, at the will of the operator. The

to make it appear new to the uninitiated, and provide sales talk for the manufacturer or salesman. One of the most valuable of these additions is a system for automatically controlling the tendency toward self-oscillation. The most prominent of these systems are Neutrodyne and the Isofarad. The diagrams of these two systems are shown in figures 7 and 8. Ob-



THE NEUTRODYNE SYSTEM

FIG. 7

Here self-oscillation is automatically controlled by the balancing condenser.

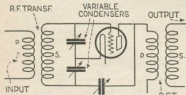

THE ISOFARAD SYSTEM

FIG. 8

Tendency towards self-oscillation is here automatically controlled.

advantage of being able to make the system oscillate is very great, as the greatest amplification is obtained when the circuits are operated just at the point before self-oscillation starts. This condition is easily found in operation, since the instant self-oscillation starts a whistle is heard in the phones when tuned to any station it is desired to receive.

In figure 6 we have the untuned system, with the exception of the first

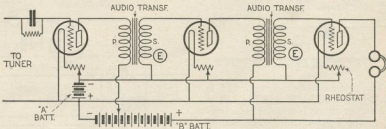

A.F. TRANSFORMER AMPLIFIER & DETECTOR

FIG. 9

The ordinary transformer coupled amplifier is, of course, untuned.

viously these may be extended to several stages of amplification.

Both of these systems work on what is known as the "bridge" principle.

of the coupling impedance and on to the grid. If this should go all the way to the grid the tube would not act properly.

Figure 11 shows the resistance amplifier, which also is seen to not differ much in essentials from the impedance coupled amplifier.

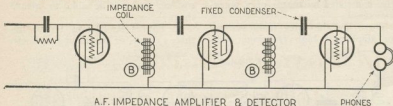

This circuit is similar to Fig. 9 except that the one winding of the impedance coil acts both as primary and as secondary.

andance coupled amplifier. The connections are in every respect the same.

The next important part of the radio receiver to consider is the circuit of the detector tube, which is perhaps more susceptible to variations than the amplifiers. The tube circuit as we have shown it in figure 1 is the nonregenerative circuit. There are several methods of obtaining regeneration in this circuit, of which the three most usual methods are indicated in figure 12.

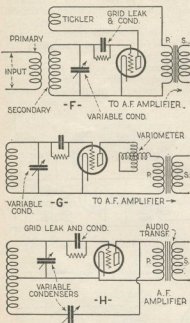

FIG. 12

Three methods of obtaining regeneration with detectors.

The first method, F of figure 12, is the tickler method, in which a coil in the output circuit is coupled inductively to the input circuit. The second method, G of figure 12, is called the tuned plate circuit method, in which there is included in the output circuit of the tube a variable inductance of some kind, as, for instance, a variometer. The third method, H of figure 12, is an adaptation of the Hartley oscillator, sometimes called the Reinartz system, which is essentially

the same as the tickler method. In all cases a by-pass capacity is required across the terminals of the device

which couples the detector to the A.F. amplifier, whether it be a transformer, impedance or resistance. In many cases it is not necessary to add a special condenser to furnish this capacity, as there may be already sufficient capacity in the windings of the

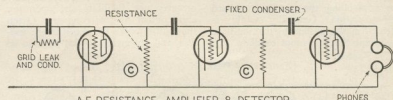

FIG. 11

Resistances are substituted here for the impedance coils.

transformer or impedance to by-pass the high frequency currents.

The tickler method may also be used to control the tendency toward self-oscillation by reversing the feed-back and extending it to one of the R. F. stages in advance of the detector. This is the system employed in the Superduty circuit, which was greatly in favor during the past few years.

There are many other variations of these systems possible, but study and the knowledge of the fundamental systems which the reader will gain from this article, he should have no difficulty in identifying them.

writers to draw the circuits properly. In figure 13 we have the principle of the reflex system, in which the output of one of the stages is made to pass into the input of a previous stage, so that the latter tube is made to perform two operations simultaneously, viz., first that of amplifying the high frequency voltages, and second, that of amplifying the audio or low frequency stages. The high frequency signal currents enter the R. F. amplifier at the input, as indicated, and the passage of the signal is as indicated by the broken line and arrows. The high frequency voltages are amplified in the first tube and rectified in the detector. They then pass on from the output of the detector to the input of the first tube again, which now acts as an A.F. amplifier. The phones or loud speaker are included in the output circuit of

the first tube. By-pass condensers are required across the terminals of the reflexing transformer and the phones, so that the high frequency currents can pass by them on into the detector. These by-pass capacities are too small to affect the low frequency or audio frequency currents being reflexed, and the tuning of the radio frequency amplifier input circuit does not in any way affect the low frequency currents. The first tube is thus made to act in two capacities and the two-tube system acts like a three-tube circuit. All reflex circuits act upon these fundamental principles, and

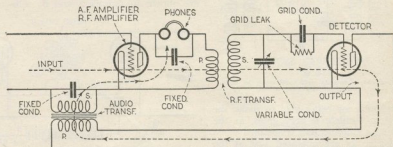

REFLEX CIRCUIT
FIG. 13

In the reflex system the tube is called upon to perform two functions simultaneously.

The reflex systems are often difficult to trace out because of the maze of wiring required in them, and also because of the failure of most radio

the whole system is easily seen to consist of nothing more than a combination of the elementary systems shown at the beginning of this article.

RADIO REVIEW READERS' BUREAU

Time and Postage Saver

IN every issue of RADIO REVIEW AND RADIO LISTENERS' GUIDE AND CALL BOOK you undoubtedly see numerous articles advertised about which you would like to have further information.

To sit down and write an individual letter to each of these respective concerns, regarding the article on which you desire information, would be quite a task.

As a special service to our readers, we will write the letters for you, thus saving your time and money.

Just write the names of the products about which you want information, and to avoid error, the addresses of the manufacturers, on the coupon below and mail it to us.

If the advertiser requires any money

or stamps to be sent to pay the mailing charges on his catalogue or descriptive literature, please be sure to enclose the correct amount with the coupon.

We will transmit to the various advertisers your request for information on their products.

This service will appear regularly every month on this same page in RADIO REVIEW AND RADIO LISTENERS' GUIDE AND CALL BOOK.

If there is any Manufacturer not advertising in this month's issue of RADIO REVIEW AND RADIO LISTENERS' GUIDE AND CALL BOOK, from whom you would like to receive literature, write his name, address and the product in the special section of the coupon below.

TEAR ALONG THIS LINE

READERS' SERVICE BUREAU,
The Conrad Co., Inc., 64 Church Street, New York, N. Y.

RR-3-26

Please advise the firms listed below that I would like to receive detailed information on their product as advertised in the issue of RADIO REVIEW AND RADIO LISTENERS' GUIDE AND CALL BOOK.

DO NOT USE THIS COUPON FOR TECHNICAL QUESTIONS

NAME	ADDRESS (Street—City—State)	List here specific article on which you wish literature.	If Catalogue of complete line is wanted check in this column.
.....
.....
.....
.....

Use this space if you desire information from a manufacturer whose advertisement does not appear in this month's issue.

NAME	ADDRESS (Street—City—State)
.....
.....

Your name..... Dealer's name.....

Your address..... His address.....

If you are a dealer, check here. City..... State..... City..... State.....

How To Get the Most Out of Your Storage "A" Battery

By RAYMOND A. KLOCK, Associate I.R.E.*

MUCH of the information generally current on the care of the radio storage battery is perfectly applicable to the auto starting battery but is misleading when applied to the Radio Storage "A" battery. It is the purpose of this article to tell, in a simple way, how to get the most out of the lead acid type of radio storage "A" battery as used for broadcasting reception in the home of the radio set owner.

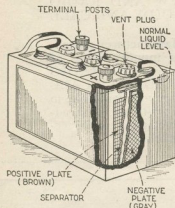

Fig. 1. A six-volt storage battery showing arrangement of its plates.

It is assumed that the reader has selected a storage "A" battery of sufficient capacity to properly operate his radio set. Except for Gould Unipower or other equipments involving the newly developed continuous or trickle charge, a standard five-tube radio set in use in the ordinary home should be equipped with a storage battery of at least 80 ampere hours' capacity. If the nameplate on the storage battery indicates a capacity of 80 ampere hours or more and bears the name of a responsible manufacturer, a five-tube radio set is correctly equipped.

The storage "A" battery is usually accompanied by a nameplate or instructions indicating its charge rate and its specific gravity when fully charged. The charge rate is not of vital importance as the rate marked on the nameplate is usually the maximum normal charging rate employed by service stations. There is no objection to a lower charge rate than the rate indicated on the nameplate, but the battery should not be charged at a higher rate except under the supervision of an expert batteryman.

Addition of Water

Fig. 1 shows the interior of a storage battery cell of the type generally used in radio. It will be observed that the liquid level is normally well above the plates and separators of which the battery cell is made up. *The plates and separators must be kept covered by the addition of distilled water from time to time.* The liquid level should never be permitted to fall to a point that will expose the separators, which are the topmost parts visible through the vent opening. However, in filling, the liquid level must not be permitted to rise into the vent opening itself. If a cell is filled so full that the electrolyte enters the vent opening, in the course of charging it may seep up through the opening and actually exude over the top of the battery to the floor.

With a properly designed storage "A" battery, filled to the correct water level a few minutes after charging, it should not be necessary to add water again until it is charged a second time. Very little evaporation occurs in a radio storage battery except while

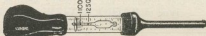

Fig. 2. Hydrometer set.

charging but considerable evaporation occurs in the last stages of charging. *When first connecting the battery or when reconnecting the battery after charging always make sure that the water level is correct.* Assuming that the battery is installed in your set, fully charged and with electrolyte at the correct level, we will now consider how to keep it in best condition.

Testing with the Hydrometer

The testing instrument most commonly employed in storage battery work is the hydrometer, shown in Fig. 2. The purpose of the hydrometer is to determine the state of charge of the battery as indicated by the *relative* specific gravity of the electrolyte. The specific gravity of a fully charged battery is not a fixed value but depends entirely on the standard specific gravity employed by its manufacturer which may be anywhere from 1.250 to 1.300. The user should always as-

certain the correct specific gravity for the make of battery he is using before attempting to test it with a hydrometer.

Fig. 3 shows how the hydrometer float checks specific gravity and, it should be noted, that the *hydrometer employed for testing the specific gravity of the radio "A" battery should be clearly marked in figures.* No dependence can be placed on a hydrometer marked "charged," "half-charged" and "empty."

When water is first added to the battery cell the upper layer of electrolyte remains mostly water for several hours so that a hydrometer reading taken on a fully charged battery to which water has recently been added may appear to indicate a discharged battery. The hydrometer reading is, accurate only after sufficient time has elapsed for the water to mix with the electrolyte, then giving a true reading.

Assuming that the solution of the battery cell has had time to fully mix, a hydrometer reading under 1.200 indicates a half-charged condition of the battery and, in general, a hydrometer reading below 1.150 indicates a fully

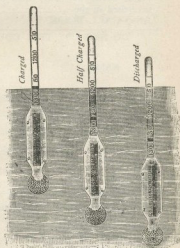

Fig. 3. How the hydrometer float checks the specific gravity of the battery solution.

discharged battery. If you employ a device for charging the storage battery at home *the battery should be put on charge sufficiently often to keep it above the half-charged state.*

* Gould Storage Battery Co., Inc.

Testing with a Voltmeter

A voltmeter may be employed as a means of testing a storage "A" battery if a voltmeter of the proper type is selected and is used in the manner described following.

The voltmeter must be accurate with a sufficient length of scale to read tenths of a volt clearly. Voltmeters are obtainable which may be used for both the "A" and "B" batteries, whether dry or storage, making an invaluable instrument to the radio user. It is not possible to test the storage "A" battery with cheap types of so-called pocket voltmeters.

Bear in mind that a voltmeter reading on a storage "A" battery is of value only when the battery is either charging or discharging, except when the battery is practically dead. A voltmeter reading taken when the battery is not connected to the circuit, either charging or discharging, may be misleading. Fig. 4 shows voltmeter scale readings which are taken at the *battery terminals*. With the radio set filament switch turned on and the tubes lighted, so long as the voltmeter indicates a full six volts the battery is charged, but, under the same conditions, if the voltmeter lags appreciably below six volts the battery should be charged in order to keep it in the best condition. When it falls to 5.4 volts the battery is discharged and cannot possibly operate the set with any degree of satisfaction more than an hour or two. When the battery is connected to the charger and the voltmeter shows from 7.5 to 7.8 volts the battery is fully charged.

Testing without Instruments

If one has neither a hydrometer nor a voltmeter it is possible to recognize the necessity for charging by the fact that the amplifying rheostats have to be moved forward of the normal working position, indicating low voltage, and the battery should be charged whenever this becomes necessary. When on the charging line, at the ordinary charge rate of the usual commercial charger, and all of the cells of the battery are bubbling, it is charged.

Charging Equipment

For reasons of both economy and convenience a device for charging the storage battery in the home is quite as essential as the storage battery itself. An additional reason, however, of equal importance is the necessity for keeping the battery in a charged condition in order to insure a satisfactory battery life. If a storage battery is kept normally less than half charged it deteriorates approximately three times as fast as a storage battery that is kept normally well above the half-charged condition. Furthermore, if a storage battery is permitted to stand for any length of time in a fully dis-

charged condition it is permanently damaged and cannot be brought back to normal capacity.

If the home of the user is located in an area supplied by direct current a direct current type of battery charger is necessary. This charger consists of a resistance unit and a meter with plug and cord for attaching it to the lamp socket. In charging from direct current it is always necessary to completely disconnect the storage "A" battery from the radio set when charging, to avoid trouble from the grounded direct current power line. The instructions of the maker of the charger should be followed closely.

If the home of the user is located in an alternating current area, usually 60 cycles, 115 volts, but sometimes 25 cycles, 115 volts, several types of commercial charging devices are available to him. It is always necessary to select a device designed by its maker to operate on the exact type of alternating current employed.

In order of simplicity of maintenance the electrolytic rectifier using the Balkite principle, the bulb rectifier using the vacuum tube principle, and the mechanical or vibrator type, are generally available.

The electrolytic rectifier requires the occasional addition of water in the same way that water is added to the

pendent on the accuracy of its adjustment.

The bulb type of rectifier is usually audible at a short distance from the rectifier. The electrolytic type of rectifier is silent.

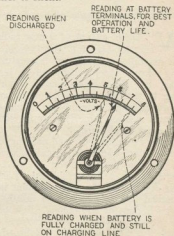

Fig. 4. Showing voltmeter scale readings taken at battery terminals.

Whatever type of rectifier you employ, follow closely the instructions accompanying it in its installation and care.

Bear in mind that for longest battery life and best radio reception the battery should not be permitted to become more than half discharged. It is desirable, therefore, to simplify the operations necessary to charging as much as possible. A convenient arrangement is shown in Fig. 5. This installation should be made with the same care that is employed in house wiring and is preferably located in the basement. It will be found that the switch can be thrown over at regular intervals between periods of use of the radio set, usually from one evening to the next, keeping the battery up with a minimum of testing and manipulation.

How to Tell When Battery Is Charged

When the battery is fully charged, as noted under "Testing" a hydrometer shows its full rated specific gravity (which may be any value between 1.250 to 1.300), it registers 7.5 to 7.8 volts on the voltmeter and all its cells are bubbling (gassing) freely.

Caution in Handling

Whether you install the switch or whether you attach the charger to the storage battery, each time you desire to charge, particular attention should be paid to the storage battery terminals. These terminals oxidize rapidly and should be scraped bright, all contacts thoroughly cleaned and binding posts screwed tight. A coating of pure vaseline should be placed over the terminals after the connection has been

(Continued on page 158)

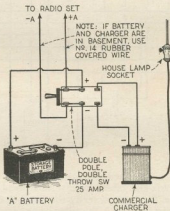

Fig. 5. A switching arrangement for charging the "A" battery of a radio set.

battery but, in the lead acid-tantalum type it has no adjustments or wearing parts. The bulb rectifier requires the replacement of the bulb, from time to time. These two types of rectifier are of approximately the same efficiency, that is to say, cost about the same in current consumed.

The mechanical rectifier requires routine adjustment of the vibrating element and occasional replacement of the contact point and is inclined to be more or less noisy. The mechanical rectifier, when at correct adjustment draws somewhat less current from the house lighting line than the other types, but it requires much more routine attention and its efficiency is de-

An Improved Super-Heterodyne

A New Super-Heterodyne Which Incorporates Plug-In Inductances

WITH the advent of a new radio season, bringing with it receiving conditions differing immeasurably from those encountered last year, the time seems most opportune to present a description of an improved super-heterodyne, designed to meet existing American or foreign broadcast conditions.

Aside from the increased number of broadcasters, and their increased power, there is the extension of wavelength ranges to be considered. Last year 250 meters was the low limit in practical use. Today it is 300,000 cycles higher, or 200 meters. Few of last year's receivers will efficiently reach this new low limit. Rebroadcasting brings in an even lower limit, so that our really practical receiver

coils are merely plugged in or out, exactly as a tube would be. The oscillator coupling coil is connected in the filament return of the first detector rather than in the grid lead, which gives somewhat greater selectivity and permits of greater efficiency at short wave-lengths.

Straight-line frequency condensers are recommended, in order that maximum ease of tuning may be experienced upon the short waves.

Vernier dials may or may not be used, as desired, but it will be found somewhat difficult to tune the receiver without them. Some friction type should be used if it is desired to take advantage of the single-control feature, which will be considered further on.

frequency band passed is so narrow that little or nothing but the low notes of a station come through.

The audio amplifier suggested employs $3\frac{1}{2}:1$ transformers. The size of the baseboard is great enough to permit the addition of an extra tube, so that a three-stage resistance coupled amplifier might be used, or a three-stage choke coupled amplifier, to be selected by the individual builder.

The circuit is not at all new, except for the use of a grid bias upon both detector tubes rather than the grid condenser and leak generally used. The reason for this is primarily one of convenience, since practically the sensitivity for either system appears substantially equal. However, a grid condenser and leak suited to broadcast

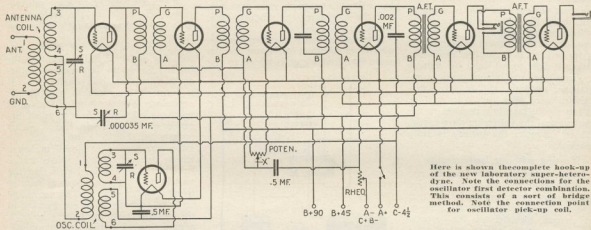

Here is shown the complete hook-up of the new laboratory super-heterodyne. Note the connections for the oscillator first detector combination. This consists of a sort of bridge method. Note the connection point for oscillator pick-up coil.

must go down to 50 meters and up to 550. If it is desired to listen to the high-powered European stations, then this range must be extended to 2700 meters.

Specifications

Possibly the first features to strike the eye are the interchange oscillator and antenna coil systems. Plug-in coils are used in each circuit, arranged to cover the desired wavelength range. Three coils are used in either oscillator or antenna circuit to tune from 50 to 550 meters. They are wound upon moulded bakelite forms.

If a loop is to be used, it is merely necessary to remove the antenna coil from its six-contact socket and connect the loop to three binding posts on the socket. For different wave-length ranges, both oscillator and antenna

transformers and filters are carefully tuned at the factory to exactly the same operating frequency, the filter being provided with a measured tuning condenser of exactly the correct value. The iron-core type is recommended. With controlled regeneration these will give as great amplification as it is possible to obtain. The over-all amplification curve of the two-stage amplifier is very similar to that of an extremely good band-pass filter as used in carrier telephone work. This means that a band only wide enough to pass the desired signal receives amplification. In this particular amplifier, the width of the band may be varied by the volume control from a width so great that selectivity and amplification are poor up through a good operating condition, and on to a point where the

reception with the first detector would be too large for good results on low waves. Further, regeneration control and selectivity improved slightly through the use of a grid bias.

The positioning of the oscillator coupling coil is evident from a reference to the circuit. It will also be noticed that only the oscillator grid circuit is tuned, thus bringing one side of the oscillator tuning condenser at ground potential, and eliminating any tendency toward hard capacity effect.

The mechanical features of the set are quite simple. Photos are shown of the shielded model. An aluminum sub-base, together with an aluminum panel shield is used. If the back, ends, and top of the cabinet in which the set is placed are also shielded, the

selectivity obtainable will be remarkable. The choice between the shielded and unshielded methods of construction is quite simple. If the receiver is less than a mile from a broadcaster, then the shielded model should be selected, by all means. Though its assembly may appear a task for a tinsmith, it is really quite simple, since the aluminum works as easily as bake-

sockets listed very nicely and are completely provided with hardware. They may be procured wound or unwound, as desired. The winding specifications are given below.

For the antenna coil, the stator tube should be wound with two equal sections, and the rotor tube with one section split for the rotor bearings as listed:

the grid circuit, the smaller in the plate circuit. For the rotor and pickup coil, the winding specifications are as follows:

190—550 meters:	
Large stator	84 turns
Small stator	25 turns
Rotor	40 turns
90—210 meters:	
Large stator	32 turns
Small stator	14 turns
Rotor	10 turns
50—110 meters:	
Large stator	14 turns
Small stator	10 turns
Rotor	6 turns

In all cases, the stators are wound as one continuous winding, the top end being No. 3, the bottom end of this winding being No. 4, the top end of the next winding being No. 5, and the bottom end of this winding being No. 6. The rotor numbers are 1 and 2. These coils may be clipped in at will and adjusted to any desired position. After being once set, they need never be disturbed.

Any standard type of tube may be employed. The writer prefers UX-199 tubes up to the second audio stage with UX-120 for the last stage. UX-201As, with the last stage UX-112, will give slightly greater handling capacity, higher "B" battery consumption and possibly, a little more volume.

Construction

Should the aluminum shield be used, holes must be drilled in it to correspond with those in the panel, but so over-sized that no instrument will short on it, except the oscillator condenser, the frame of which goes to the negative filament line, which is also the shield.

If the sub-base is of wood, wood-screws will serve to fasten all parts to it, and it, in turn, to the panel. If an aluminum sub-base is used, machine screws (6/32) and nuts will be required.

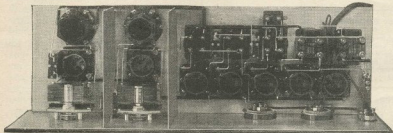

This view of the new super-heterodyne shows the parts with two of the inductances in place in the receptacles. It also shows the method of building.

lite, and may be obtained cut to size. The unshielded model is entirely satisfactory for use outside a one-mile radius of a powerful broadcaster.

Results

Generally, writers of constructional articles feel that their work is incomplete without a glowing tale of the wonderful results obtained from their particular circuit. The writer is no exception, nor is it assumed that the reader would wish to remain uninformed of what may be expected from the sets. During August a test was run in a building adjacent to a new steel frame hotel in the Chicago loop district. Some twenty out-of-town stations were logged between nine and twelve o'clock including coast stations. More were heard, but could not be logged, due to terrific static and elevated railway interference—located less than 75 feet away. However, the important fact is that within a radius of but a few miles, some ten local stations were operating—three of them not half a mile distant. Yet the selectivity was such that no trouble was experienced in working.

Parts for this set should be selected which will co-ordinate properly, and are of equal quality, since the results obtainable are dependent, in a large measure, upon the use of parts selected.

A list of material is given in the accompanying box.

If the completely shielded model is to be built, additional aluminum shielding will be required. The sub-base should be No. 8 gauge, while the balance may be No. 20 gauge, cut to fit the desired cabinet.

No specifications for the oscillator coils have been given. It is possible to use standard six-contact forms for these coils, which can be procured on the market, as these will plug into the

- | | |
|---|-----------------------------------------------------------|
| 2 | .00035 SLF condensers. |
| 2 | 4" moulded dials, vernier preferably. |
| 1 | 6-ohm rheostat. |
| 1 | 200- to 400-ohm potentiometer. |
| 1 | 2-Spring jack. |
| 1 | 11-Spring jack. |
| 2 | Charted intermediate transformers. |
| 1 | Tuned filter with condenser. |
| 7 | Spring sockets, UX or UV. |
| 2 | 3½:1 audio transformers. |
| 1 | On-off switch. |
| 3 | 3 mf. bypass condensers. |
| 1 | .002 bypass condenser. |
| 1 | .000225 mf. balancing condenser. |
| 1 | 7x24x¼" bakelite panel. |
| 1 | 7½x23 oak or aluminum sub-base. |
| 2 | Coil sockets, screws, lugs, nuts, solder, spaghetti, etc. |

190—550 meters:

Stator	43 turns per coil
Rotor	40 turns per coil

90—210 meters:

Stator	16 turns per coil
Rotor	10 turns per coil

50—110 meters:

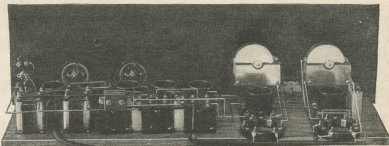

This view of the new super shows the arrangement of the parts with the two receptacles for taking the inductances. The model picture is the unshielded type.

Stator	7 turns per coil
Rotor	6 turns per coil

For the oscillator system, the top stator coil is much larger than the bottom one, the larger being used in

The wiring is quite simple, requiring only the usual bus-bar, spaghetti, well-tinned soldering iron, non-corrosive paste and rosin-core solder. No battery binding posts are provided, the short

BEEDE

SAVE THEIR COST—STOP MOST SET TROUBLES
Don't blame the set when the trouble is probably weak batteries. Don't blame the batteries when loose connections might be causing the noises. Use BEEDE METERS and KNOW the state of your batteries.

POCKET TYPE BEEDE METERS

Type 101 Ammeter
Measures current in any make dry cell by placing either terminal of meter on either pole of cell. Permits reading 2 or 3 cells at one time.
Price 90c

Type 206 Voltmeter
Especially designed for determining voltage of Radio B batteries. Shows instantly the condition of 22½ or 45 volt units.
Price \$1.25

Type 209 Voltammeter
Combined ammeter and voltmeter 0-50 volts; 0-50 amps. 2 scales for dry cells or storage batteries.
Price \$1.50

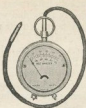

for
PANEL MOUNTING
High resistance instruments made in a wide variety of ranges. Made in two sizes. Price from \$2.50 to \$4.00.

ALL BEEDE METERS ARE GUARANTEED ACCURATE
Write For Catalog

BEEDE ELECTRICAL INSTRUMENT CO., Pennock, N. H.
New York Office, 136 Liberty Street

METERS

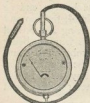

RADIO BARGAINS

FREE RADIO CATALOG & GUIDE of newest ideas, over 100 approved aerial book-ups with instructions. Tremendous savings on standard radio parts, sets, kits. Be sure to get this thrifty book before you buy. Write: **Wendell Unsicker**, You'll say so. Write letter or postal NOW. **BARAWIK CO.**, 102-122 S. Canal St., CHICAGO, U.S.A.

Ask your newsdealer
to save a copy of Radio Review for you
The Consrad Company, Inc.
64 Church St., New York, N. Y.

The "Radio News" Radio Wrinkles

Just issued—112 Pages of Radio
Wrinkles—in one great Book.
Fully Illustrated—Large Size 9x12 inches.
PRICE 50c.

The Experimenter Publishing Co., Inc. 53 Park Place, New York, N. Y.

ends of the color cable being terminated directly at instrument binding posts, while the long ends go directly to the batteries.

The preliminary testing of the set is quite simple. It should first have only the "A" battery connected to it, and the tubes inserted in their sockets. They should, of course, light, and have their brilliancy controlled by the rheostat. The negative "A" battery lead should be left connected and the plus lead removed and touched first to the "B" 45 and then to the "B" 90 leads. The tubes should not light with either of these connections. If they do, an error has been made in wiring and must be corrected before proceeding further.

The tubes being in their sockets, the rheostat should be turned about seven-eighths on for storage battery tubes. The proper adjustment for UX-199 tubes (dry cell) may be arrived at by the use of a filament voltmeter, which

is vitally important for use with this type of tube.

Two of the larger size oscillator coils and antenna coils should be put in their respective sockets, and the balancing condenser turned all out. Then, if the potentiometer is turned from its positive to its negative side, a "plunk" will be heard, followed by squeals if the oscillator dial is rotated. The potentiometer should be turned back far enough so that no squeals will be heard in which position it should be left unless it is desired to vary the signal volume with it.

If the oscillator and antenna dials are rotated slowly, varying the oscillator through a range of 10 degrees above to 10 degrees below the antenna setting for each 2-degree step with the antenna dial, signals will be heard if any local stations are operating. An antenna not over 40 to 60 feet long, indoor or outdoor, and a ground may be connected to terminals 1 and 2 of

the antenna coil socket, or one just behind the antenna condenser and first detector tube. Selectivity may be regulated by adjusting the position of the rotor coil with the fingers. Once set it need not be disturbed. This is true for all sizes of antenna coils, for the different wave-length bands.

The oscillator coupling is not generally critical and the oscillator rotor should have its axis coinciding with that of the stator tube to start with. Selectivity may be improved by turning it slowly out. It will be found, however, that turning it a full 180 degrees around may increase signal strength on weak stations. In some extreme cases it may even be necessary to connect it in the first detector grid lead rather than in the filament return. This should be tried at once, should the receiver fail to operate properly.

In first tuning the set a few signals will be heard, due to the extreme selectivity. Therefore, it may be well to do away with the regenerative first detector circuit temporarily by reconnecting the circuit as suggested in the circuit diagram. This will render the antenna tuning quite broad, with consequent ease of handling, but at the expense not only of selectivity, but of a considerable degree of sensitivity.

Single Control

Using the non-regenerative first detector connection, the antenna tuning will be broad enough so that if the two tuning condensers are geared together, one knob may be used for tuning, thus simplifying control. This is as practical an arrangement as can be used in any super. The antenna tuning being broad, it is impossible to vary both condensers at once, keeping them a uniform number of degrees apart, and yet still obtain the best setting for all waves on both condensers.

In view of the single-control feature, the use of a loop has not been seriously considered. However, it may be used with perfect satisfaction as on any super, by removing the antenna coil and connecting the loop with its inside end to post 6 of the coil socket, its center tap to post 4 or 5, and its outside end to post 3. This assumes a spiral loop, of 18 turns, about 20 inches mean diameter with turns spaced one-half inch between centers. Stranded loop wire should be used—not Litz. For shorter waves, fewer turns will be required—say about eight for the 100- to 200-meter band and about four for the 50- to 100-meter band.

In the case of some standard loops, wound with few turns, it may be necessary to add a turn or two to cover the desired maximum range up to 550 meters.

A Practical "B" Battery Eliminator

By C. E. JACOBS

How to Build a Smooth and Flexible "B" Eliminator Using Electrolytic Rectifiers

WITH present day receiving sets, using as high as 10 tubes the question of B batteries becomes an item of a good deal of bother and expense. In 90 per cent of all cases of poor signals, loss of selectivity and sensitivity, it is either the fault of the A or the B batteries, mostly the latter. Then, too, there is the expense. On the average five tube receiver a set of dry cell B batteries of a good make will last about three to four months, while on larger sets they will not work well after a month's use. No wonder, the average fan, after having operated his receiver for some time, turns to some substitute for B batteries, but it is equally surprising that not more B battery Eliminators are being built when it is comparatively easy to do so. The parts may be readily obtained and any fan that can assemble a crystal receiver can wire up a B Eliminator in a short time. It is not necessary to be very particular about the layout of the wiring, as we are not dealing with any tricky high frequency currents, and if a little care and caution is used in the choice of the material and parts, the builder will be amply rewarded for his efforts.

used on a variety of receiving sets. It is low in first cost as well as in upkeep. The current consumption of such a B Unit is, as a rule, not more

placed at nominal cost. In this respect the chemical rectifier has the advantage over rectifying tubes whose average efficient life is not more than

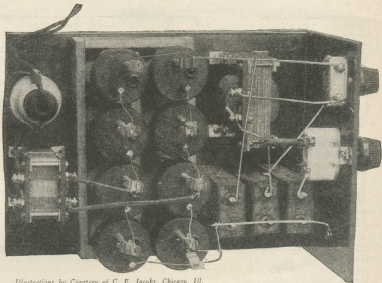

Illustrations by Courtesy of C. E. Jacobs, Chicago, Ill.

Photo showing a top view of the "B" battery eliminator.

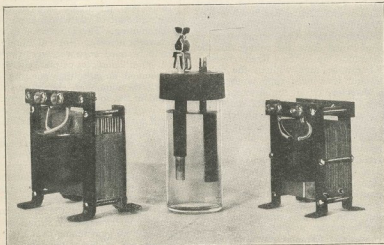

Here is shown one of the electrolytic cells and choke coils as used in the eliminator described herewith.

In the following article a B current Supply Unit is described which is not only very smooth in action, but also flexible enough so that it can be

than 7 or 8 watts, or far less than an ordinary light bulb would consume. The wearing part of this B Unit which is the chemical rectifier can be re-

600 hours. Every B Supply Unit that is to be used with alternating house current consists essentially of four sections. These are, the power transformer which steps up the house current to a higher voltage, the rectifier system and the output voltage regulation.

In the B Unit to be described herewith, a 25 watt transformer is used which steps up the 110 volts of the house current to 155 volts. This figure has been found to deliver about 40 milliamperes of current at 90 volts on the output side of the Eliminator. For the construction of the power transformer we can take any convenient toy transformer, that has a rating of around 25 watts. Unwind the primary winding which is next to the core and count the number of turns thus unwound. Divide this number by 110 which is the line voltage and we now have the number of turns per volt. Carefully rewind the primary on the core, taking care that no open or short-circuit creeps in. Wrap a layer of

Empire cloth around the primary and bring out the free ends to suitable binding posts. These will be connected to the house current. Now in order to find the right number of turns for the secondary we multiply the number of turns per volt with the secondary voltage desired. For instance, if we have 8 turns per volt on the primary winding and we want 160 volts on the secondary, we must wind on 1280 turns. The wire must be wound in even layers and each layer should be insulated with thin paraffined paper. The whole assembly should then be

choke coils is to be discouraged. They have neither the proper inductance, and as a rule where a high ratio instrument is used, the DC resistance as well as the distributed capacity of the windings are far too high to get good results. In connection with the choke coil we also require large capacity filter condensers. These should be high grade and must stand a high voltage test. For the B Unit in question condensers made by the larger Telephone Companies or filter condensers made for B Eliminators should be selected. In the diagram

and aluminum in a solution of ordinary borax. However, during the past few years when considerable research work has been done with this type of rectifier in connection with its use as a B battery charger, various defects have shown up and these have now been eliminated. For instance it has been found that borax would eat away the aluminum electrodes very quickly. This required frequent renewal of the electrodes and also of the solution. Various chemicals have been found which did not possess this disadvantage and if they are procured in the chemically pure state, the aluminum electrodes will show an unusually long life. A few of these chemicals are sodium phosphate, ammonium phosphate, to which has been added a slight amount of potassium phosphate, sodium acid tartrate, and ammonium borate. A good many of the battery charger manufacturers are putting out chemicals which can be used in the rectifier cells.

An improvement has also been made in the choice of the cathode material. While, this, as a rule, consisted of lead, a few manufacturers are now using specially made graphite electrodes which are similar in appearance to the carbons used in dry cells. Graphite does not undergo oxidation or electrolysis while used as a cathode in the rectifiers and, therefore, does not rob the solution of its active elements. At the same time it will always stay clean and makes good contact with the electrolyte, while lead, due to its corrosion sets up a high resistance with a consequent drop in the output of the rectifiers.

It is also important to have the proper amount of aluminum exposed to the solution. This is referred to as the current density. For a B Eliminator to be used on a receiver where about 40 milliamperes of plate current is consumed, no more than one square inch of the aluminum should be immersed in the solution. For the average five-tube receiver an immersion of half inch using a rod $\frac{1}{4}$ " in diameter works out very well. Too large a surface exposed, where only a small amount of current is consumed, means poor rectification with a resultant difficulty in filtering out the hum. In the photograph of the single rectifier cell, it will be noted, that the area of immersion of the aluminum electrode is regulated by shrinking a piece of pure gum tubing over the aluminum rod. This at the same time prevents the sparking at the surface of the solution, which, in time, corrodes the electrode to such an extent that it will be useless.

The aluminum used in the rectifiers should be of the highest purity obtainable. Chemically pure metal should be procured. Ordinary aluminum will

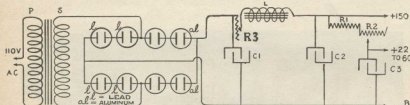

Wiring diagram of the electrolytic "B" battery eliminator as shown in the photos.

wrapped in Empire cloth and can be soaked in molten beeswax or left as it is.

In the accompanying schematic wiring diagram of the B Current Supply Unit, it will be noted that 8 rectifier cells are used. These are arranged in what is called a bridge circuit which provides full wave rectification with but a single secondary winding on the transformer. The number of rectifier cells is determined by the secondary voltage and it is a rule to have one jar for every 40 volts. With a full wave rectifier this means twice the number as each cell rectifies only one half of the AC wave.

The current in passing through the rectifiers is changed from alternating to direct but pulsating current. Now, this current would cause a strong buzzing sound in the receiver if it were used just as it is. It must, therefore, be smoothed out to a steady flow of pure direct current, so that there will be no fluctuation in its supply. Any fluctuation of the supply would have a tendency to modulate the received signal, and the result would be a choppy or "ragged" signal. The smoothing out of the pulsating current is effected by the filter system. This consists essentially of a large reactance coil, commonly called a choke coil, and large capacity filter condensers. It has generally been suggested to use a choke coil of 30 henries, but for real good results on a receiving set a much higher value should be used. Sixty henries is none too much and 100 to 125 henries will work better. In fact, the heavier the inductance, the better, providing, of course, that the DC resistance does not exceed a certain value. The use of audio transformers as

shown, C1 and C2 are 2MF each, while C3 is 1MF. These values are not critical, but should not be smaller. On the contrary, the larger the condensers, the better will be the filtering. In order to get the proper voltage taps, either fixed or variable resistances should be used. Fixed resistors are probably better, but the variable ones are more convenient. In selecting the latter, make sure that they are able to carry the currents which they are intended for without burning out or losing their operating characteristics. Referring to the diagram, R1 is a fixed resistance of 125000 ohms while R2 is a Bradleyohm, No. 10 which varies from 10,000 ohms to 100,000 ohms. This arrangement is used to cut down the voltage for the detector tap. The fixed resistor R1 can be used without the Bradleyohm if a hard tube is used for a detector, or if the detector voltage is not critical, but R2 should always be used in series with R1. The variable resistor R3 which is put in ahead of the choke coil is also a Bradleyohm No. 5 which has a range of from 1,000 to 10,000 ohms. This is used for regulating the amplifier voltage. On sets requiring more than two positive plate voltages, this may be arranged by tapping into the amplifier line with another variable resistance and by-passing its output with a fixed condenser. (This is not always necessary, as the by-pass condenser of the receiver will take care of this).

The heart of the B Supply Unit is the rectifier element. In the Unit described herewith, the electrolytic type in which aluminum serves as the rectifying element is made use of. Heretofore, the average experimenter has always used a combination of lead

not work at all, or only fair. Most of the larger chemical houses can supply C. P. rods, but for the best results this should be bought from manufacturers of B battery chargers or rectifiers for B Units.

It is also important to use nothing but distilled water for the solution and the latter should be saturated. Do not use a hydrometer for filling the rectifier cells, if it has ever been used for testing a storage A battery. There will be enough acid sticking to the glass wall of the hydrometer to spoil the solution and the electrodes.

same cabinet without experiencing any hum on the loud speaker. On loop operated receivers it is sometimes necessary to ground minus B.

The evaporation of the solution in the cells is very slow. As a rule adding a few drops of distilled water twice a year will take care of this. The life of the solution itself will vary considerably. In some cases it might be as short as 6 months, while in others it is good for two years or more. This is the great advantage of the chemical type of rectifier over any other system. The total costs, both

1 Bradleyohm No. 10 (10,000 to 100,000 ohms).

1 Bradleyohm No. 5 (1000 to 10,000 ohms).

The construction of the choke coil is rather tedious and is a job not recommended for the average experimenter. A good many fine points will have to be observed which space forbids to mention here, but for those fans who have sufficient knowledge of coil windings and transformer assembly, it is suggested to use a core of one inch square cross section with a winding of 9000 turns of No. 32

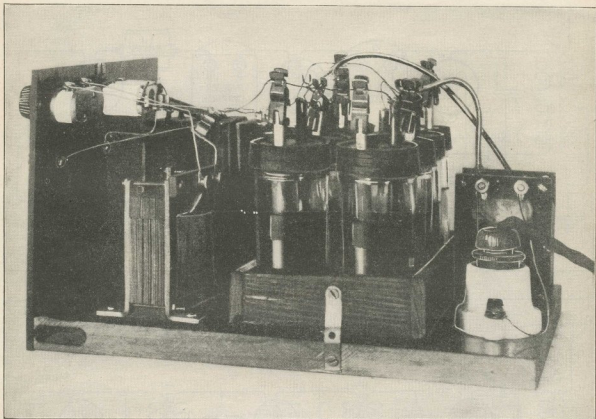

Another view of the "B" eliminator. Note the socket at the right for connecting the unit to the lighting supply line.

With the B Current Supply Unit assembled, we now turn on the house current and form the electrodes. With the bridge arrangement of the rectifier cells, this will be done in 5 or 10 minutes or sufficiently well to operate the receiver. The forming will get better after the B Unit has been operated a few days, but the Unit can be used on a receiver almost at once.

There should be no perceptible hum, even when the headset is used, but any residual hum can be eliminated by increasing the capacities of condensers C1 and C2, preferably the latter. The B Supply Unit itself should not be very near the receiver itself, but in some cases it can be set into the

operating and replacement of the chemical B Unit for 1000 hours operation should not be more than \$1.50 to \$2.00. In a good many cases it is even less than \$1.00 per year.

To summarize, the parts required for the building of the Electrolytic B Eliminator are:

1 power transformer with a secondary of 150 to 170 volts?

1 choke coil of 125 henries at 60 cycle no load.

8 rectifier cells.

2 filter condensers of 2 M F capacity.

1 filter condenser of 1 M F capacity.

1 fixed resistor R1 (125,000 ohms).

wire. The wire should be wound in even layers and the distributed capacity must be kept low. One leg of the core should be assembled with a butt joint while the others are interleaved as in regular core assembly.

The B Current Supply Unit constructed after above instructions is exceptionally smooth and very flexible. The detector voltage can be regulated to a point where a soft tube can be used with good success, while the amplifier voltage can be varied from 75 to as high as 135 volts with a current draw of 20 to 25 milliamperes. This will handle a Tuned Radio Frequency receiver with resistance coupled am-

(Continued on page 119)

Fixed Condensers

By M. KEVELSON*

Their Position and Function in a Receiving Set

IN every radio set, a fixed condenser is a practical necessity. The diversity of uses to which it is

portant for the manufacturer and builder of radio sets to know the why and wherefore of fixed condensers.

portance because in practically every instance, if the condenser is properly located in the circuit, the part that it

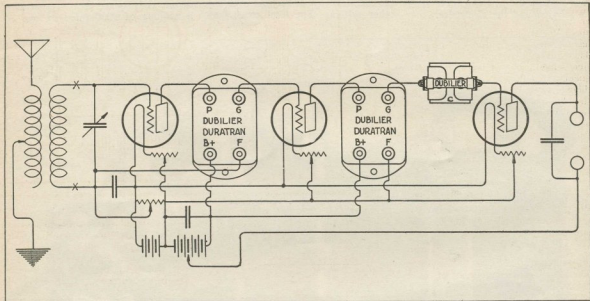

Illustrations by Courtesy of Dubilier Condenser and Radio Corp., New York.
Fig. 1.—Fixed condenser at C used as a grid condenser in the detector circuit.

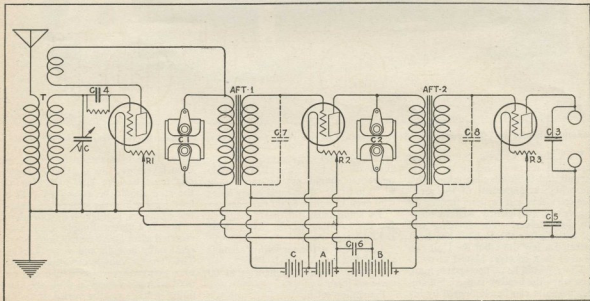

Fig. 2.—Fixed condenser at C₁ and C₂ used as a by-pass for radio frequency currents.

put, and the part played electrically in each of its positions, make it im-

portant to know the relative im-

portance of each of its positions, that it is almost indispensable. In fact, it

*Dubilier Condenser and Radio Corporation.

many cases it is an absolute necessity.

The most important use of fixed condensers is in the position of grid condenser (Fig. 1) in the detector circuit where it so modifies the action of the vacuum tube, which is normally an amplifier, as to make it a very superior form of rectifier; in fact, not only a rectifier, but a very efficient form of audio detector. Radio waves as sent out by a broadcasting station are continuous waves modulated according to the speech or music signal. These modulations consist of an aggregation of frequencies from about 25 to 5,000 cycles per second, having various amplitudes and phases. The continuous waves, known as carrier waves, are of such high frequency, that they are not directly audible. Even if it were possible for the human ear to respond to such rapid vibrations, we could find no mechanical contrivance, such as a telephone diaphragm capable of vibrating at this rate. It becomes necessary, therefore, to take these high frequency currents and convert them into currents of audible range, for which purpose it is necessary to rectify the incoming pulses, that is to say, make them uni-directional. Variations in these uni-directional pulses are of audible frequency and can, therefore, be heard in the head-set. There are several methods of recti-

sible. The effect of a grid condenser used with a vacuum tube is to allow the tube to rectify the incoming pulses and amplify them at the same time. This is really the chief advantage of the grid condenser rectification scheme. It permits of simultaneous rectification and amplification by one tube. The size of the condenser used for this purpose is either .00025

transformers when placed in the plate circuit of a vacuum tube, cannot pass currents of a very high frequency because of the choking effect they exert on such currents. This choking effect is caused primarily by the iron core in the transformer. Since it is necessary to pass radio frequency currents in this same circuit, the only means by which this can

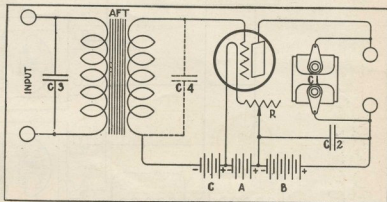

Fig. 3.—Another example of a fixed condenser, shown at C, used as a by-pass for radio frequency currents.

mfd., or .0005 mfd., depending on the characteristics of the vacuum tube used, and the range of frequencies being received.

Another use to which fixed condensers are put is as a by-pass for radio frequency currents (Fig. 2 &

be accomplished is by placing a small fixed condenser across the primary of an audio frequency transformer. This condenser will allow currents of radio frequency to pass through it, but will deny the passage of audio frequency currents. Conversely, the

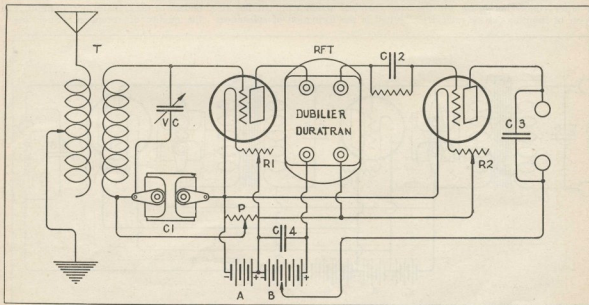

Fig. 4.—Fixed condenser at C, used as a by-pass across the potentiometer.

fying these radio frequency pulses, the most efficient of which is by means of the grid condenser. It must not be supposed that the grid condenser of its own accord acts as a rectifier, since from the electrical nature of a condenser this is impos-

3). In practically every circuit, such as the regenerative, neutrodyne, reflex, etc., it is absolutely necessary to pass currents of two different frequencies simultaneously from the output of one tube to the input of a succeeding tube. Audio frequency

primary of the audio frequency will pass audio frequency currents and prevent the passage of radio frequency currents. Thus, the necessity of a condenser across iron core inductances is apparent.

In addition to this use of fixed condensers across inductances, there are other uses, such as by-pass across resistances and batteries. An example

An important use of fixed condensers which is of economic value rather than electrical, is in the position of by-pass across a "B" battery.

electrodes. By the use of a 1 Mfd. condenser across the battery, (Fig. 5) are smoothed out, giving a steady these minute fluctuations in voltage

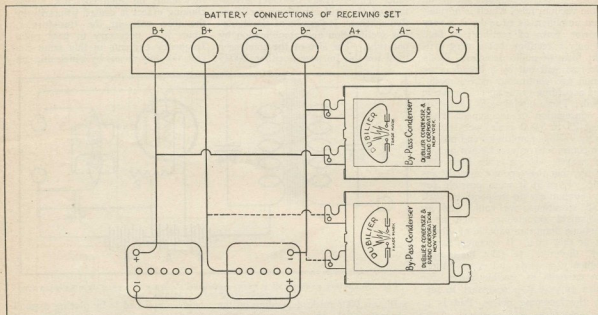

Fig. 5.—Diagram showing the use of 1 mfd. condensers across "B" battery.

of the former use would be as by-pass across a potentiometer, (Fig. 4) while an example of the latter would be as by-pass across the "A" battery; this latter connection being for the purpose of shunting out the radio fre-

When a "B" battery is new, its internal resistance is very low and it is devoid of all internal local action. After it has been in use for some time, the chemical action within it has resulted in the formation of substances

flow of current devoid of all noise.

In transformer coupled amplification it is possible by the judicious use of a fixed condenser across the secondary of the transformer, to improve the quality of reception. Such use

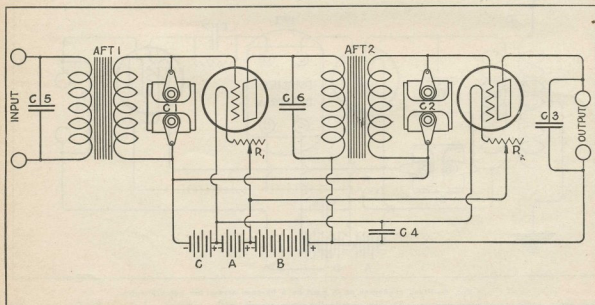

Fig. 6.—Condensers placed across the secondaries of the audio frequency transformers at C_1 and C_2 for the purpose of improving the quality of reception.

quency resistance of the battery leads when the batteries are situated at some distance from the set.

of very high resistance and there results continual minute fluctuations in voltage due to local action on the

would be advisable where a transformer is of very high ratio, and in consequence the voltage amplification

is very high at high frequencies giving a peaked amplification curve. It is then possible by placing a condenser across the secondary (Fig. 6) to flatten out this upward characteristic, and thereby reduce the distortion at the higher frequencies.

The proper use of fixed condensers

operating point of a tube is for a slightly negative or normal grid potential, the simplest remedy lies in the use of blocking condensers in the grid leads. This solution, however, introduces a difficulty, for regardless of the size of condenser used, its reactance will vary with the frequency. It is the

.006 Mfd may be used without any appreciable distortion. However, for best results, a capacity of .02 Mfd. is recommended. With a well constructed amplifier the grid resistance should not be less than 1-2 megohm, and the negative bias of the last tube should be considerable. The faithful-

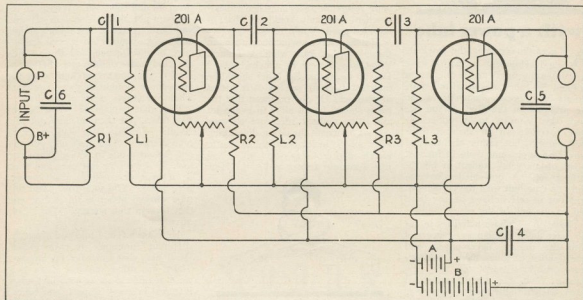

Fig. 7.—Diagram showing the correct use of fixed condensers in a resistance coupled amplifier.

in a resistance coupled amplifier (Fig. 7) makes this type of amplifier, without doubt, the most faithful of reproducers. This item is so important in the design of resistance coupled amplifiers that the use of an incorrect capacity will result in this form of amplifier distorting to even a greater extent than transformer coupled amplification. One of the most important problems in the design of resistance coupled amplifiers is the avoidance of communicating the "B" battery voltage drop across the external plate circuit resistance to the grid of the succeeding tube; for under these conditions, the grid will have a very large positive potential. Since the best

real cause of distortion in any resistance coupled amplifier. The larger it is made, the less the distortion. The reason for the distortion is that since the voltage drop through the condenser varies with the frequency, the voltage impressed on the succeeding grid is different with different frequencies from the voltage output across the plate resistance. It is entirely possible by the use of a very small condenser to cut off nearly all of the voltage at the lower frequencies, thus causing considerable distortion. The proper blocking condenser to use in a radio frequency amplifier is not necessarily as high as 1 or 2 Mfds. Condensers as small as

ness of reproduction of this type of amplifier is about as perfect as it is possible to obtain at the present time. It is quite apparent therefore, that the blocking condenser in this type of amplifier is of paramount importance.

In choke coil amplification the blocking condenser serves the same purpose as in resistance coupled amplification and it should be of approximately the same size.

There are many special circuits in which fixed condensers may be used as coupling condensers, such as the Browning-Drake, super-heterodyne, super-regenerative, reflex, and the like. In most of these circuits they serve as by-pass condensers.

A Practical "B" Battery Eliminator

(Continued from page 115)

plication very nicely. For a Super a voltage of 90 to 100 is available with a current draw of 40 mils. The whole assembly can be mounted on a baseboard 9x12 inches and the panel can be a strip of rubber or bakelite 2x9 inches. The various views show the assembly from different angles, while a separate view shows the transformer and choke coil, also one of

the rectifier cells. The jars used for the latter should be fairly large. The standard storage battery jars will do very well for this purpose, but all traces of acid must be removed from the jars and the rubber caps.

In conclusion the writer wishes to state that the construction of this B Unit will amply reward the builder for his efforts. Many a receiver that

performs only in a mediocre way when B batteries are used will deliver a much clearer tone and crisper signals when current is supplied with the B Unit. Local stations can be tuned down for fine tone shadings and distant stations will be loud and clear by adjusting the amplifier voltage to the best point for the particular receiver.



with a power tube

AS ever, in watching the fascinating developments in radio, I have been intensely interested in the recent demand for tubes of specialized characteristics for specific purposes. I use the pronoun in the first person because this is meant to be, not a solemn discourse on an abstract technical subject, but rather an informal conversation on some items of interest to the ordinary lay student of his receiving set. A one-sided conversation, 'tis true, but then the reader can tune out in self defense at any time, and no one will be the wiser.

Those of us whose activities in radio have been principally concerned with the design, development, and manufacture of tubes, have long foreseen, and long advocated this new point of view, this idea of specialized tubes, each designed for a particular purpose, and that is why we find it so gratifying that our ideals are beginning to bear fruit.

There are many things going on in your set while you sit there listening to your favorite orchestra, more things, Horatio, than you wot of. And nearly all of those things are being performed by your tubes. Not quite all. Because although the tubes are the heart of the set, yet neither can function without the other. The tubes are an integral part of the circuit. Their functions, and the manner in which they carry them out, are in part dependent upon their own characteristics and for the rest dependent upon the characteristics of the circuit. Your set with different tubes will behave differently. That is why when you change only one tube you will nearly always have to readjust your tuning, rheostats, and potentiometer. And your tubes in a different set will act differently, do different work, and do it differently. Nay, more, your tubes, if rearranged in your own set, will display these differences.

In a more or less vague way you have known this all along. And when somebody said to you, "Look here, see how differently these tubes behave when you change 'em around? You ought to get tubes that won't behave that way. You want tubes that are all alike so you can change 'em around carelessly, without spoiling

The Passing Fallacy of Matching Tubes

By JACOB HOLENSTEIN*

your reception. Get matched tubes,"—when somebody told you that, it sounded good, didn't it?

Matched tubes—what magic in those words! And what a fallacy. What do you mean by matched tubes? Do you mean that the tubes should be matched to your set, to each socket in your set? Or do you mean that the tubes should be all alike in every job and tittle, without reference to your set? You meant the latter, didn't you. Fess up. It never occurred to you to match any tubes to your set. You just went into a store and said, "How

them in, and that's all. Whatever result you get, that's what you get, and you can't change it. The thing's simple and easy, requires no special knowledge or intelligence, and thus avoids all kinds of trouble and difficulty. Really, you can't find fault with the people who thought this way, can you? Their intentions were of the best.

But what happened? You bought five tubes, put them in, and got fair results. Perhaps you had an extra tube around. You took one out and put the extra one in. Fine. Then you took the tube now left over and tried it in another socket. Here worse, here better. You soon found that this tube worked better in this socket and that tube in that socket. Why? Lots of reasons.

Here are a few. I told you about the different functions of each socket. We'll pass that over for the present. There are other reasons. Even if it were possible to make a million tubes, identical in every respect, and believe me, it isn't, if you take a few of them, and ship them from factory to distributor, from distributor to dealer, and then carry them home, you will shake them a bit and the internal spacing of the elements will be deranged a little. Just a little,—but enough to make your twin tubes quite unlike. Your tubes have been altered a little in spite of every precaution. This tube has been improved for this job, but it's been spoiled a bit for that one. And remember, I said that it isn't possible to make the tubes identical. Bear in mind that a tube is a highly technical scientific instrument, a laboratory instrument, indeed. It looks quite innocent, but what a world of intelligence and care went into it what a sophisticated body it really is! Well, if a little jar changes it, how about a thousandth of an inch longer or shorter filament, or a ten thousandth



the gentle art of switching tubes

about matched tubes?" And the man said to you, "Yes, sir, how many?" And you said "Five," or "Three," or "One" (don't laugh—I've seen it happen) as the case may be. And you took your tubes home and maybe you got a little better results, and maybe you got poorer. If you got better results you said "That's good dope; matched tubes are the cat's." And if you got worse results, you said the tubes weren't properly matched.

Now how did this idea of matching tubes originate? In a perfectly sensible and legitimate way. You know how our entire civilization is a constant struggle between two great principles, a constant effort to adjust two great opposing tendencies, namely: "Standardization" vs. "Specialization." Well, here's how it worked out. Leaders of the tube manufacturing industry decided to put out just a few types of tubes, let's say one type for dry cells and one for storage batteries. Take one of these, the three volt tubes for example. Those tubes were to be made with the utmost possible uniformity, so that you could go into a store and buy one like you would buy a bar of laundry soap, for instance. You go home, put it into your set, push your switch, and you're through. Or you buy five tubes, put



"gimme one matched tube"

*Sales Manager, Consensus Elec. Laboratories.

of an inch difference in the diameter of the grid wire. You ain't heard nothin' yet, as Jolson sings, but you know what I mean. No, indeed. The best we can do, and it's a lot, really, is to use a very rigid standards, and very narrow requirements, paying attention to two things,—first, that the average values shall be such and such, and second, that the tube must be within so much of the average. That's matching, properly done. Anything further than that is really not representative of sound knowledge of the manufacture of tubes.

So that's how this "Specialization" idea began to get the upper hand in radio. If this tube makes a better radio frequency amplifier than that one, how come? And if my pet audio amplifier tube burned out, how could I ever replace it? I was pretty lucky to catch this one.

The technical end of all this readjustment of ideas kept progressing in the laboratories. We worked out what a detector should be and do, what an r. f. tube should be and do, and what the audio tube should be. The oscillator, the rectifier, the various stages of amplification have all been carefully studied, and while we do not yet know all there is to know about tubes, we've certainly been making wonderful and rapid strides. After all, fond reader, who does know all there is to know? Take all the knowledge that every first class tube engineer has about tubes, today, and put into book form and you'll have a dozen volumes or so. But come back to that shelf in the library next year and count the volumes. And the year after and the next generation. Really, we've hardly scratched the surface. Yet I might mention, with justifiable pride you will agree, that it is incontrovertible that America's knowledge of tubes, and American tubes, excel greatly those of the rest of the world.

But let's get back to the plot. I promised not to get technical, and I won't. But we must look at tubes a little more closely for a moment. And then if you want to follow the technical side of this discussion a little further, perhaps in a subsequent article we can take that up.

What does a detector do? It takes minute alternating electrical impulses of extreme complexity and of great frequency and irons them out a bit and sifts them a bit, side-tracking part, and giving you the rest in agreeable audible form. It has to be extremely sensitive. What does that mean? Why, simply that an extremely faint impulse should be able to stir it, make it step. We'll not, at this time, go into the relative values of hard and soft detectors. That's on the table for future discussion. But, hard or soft, the detector should cer-

tainly have a low internal impedance, by which we mean that it should offer small resistance to the passage of plate current through itself. Its grid control should be great, but within such limits that it will not distort the signals it gets. Enough for that.

What does the radio frequency amplifier do? It takes this very faint and very complicated alternating impulse and magnifies its every convolution, so that it can be more easily handled by the detector. That's why r. f. gives you distant signals. Your detector might not be able to do its stuff, until the r. f. amplifier has enlarged the radio wave. So the r. f. tube must be sensitive, but low impedance isn't as important as a high voltage amplification, called the amplification constant. That should be great, very great. And the tube should be extremely hard so that no distortion can enter. The tube doesn't have to pass much current, but must pass along the impulses it gets with no change of any kind except to magnify them exactly, or pep them up as much as possible.

Now how about the audio frequency amplifier? That tube gets the rectified impulses that the detector is sending out. The frequency is low, and the current is comparatively heavy, but direct, not alternating. It has to magnify those impulses, but its job is a little easier in one way, though harder in another. It doesn't have to dance to such extremely complicated measures as its predecessors. But it has to handle much more power, and increase that power. So its impedance must be low to pass as much

cuits are in use, for one thing, and the appropriate tubes are not yet available, myhow.

"Well," you say, "suppose I agree with you that I ought to have specialized tubes for each socket in my set, what am I going to do about it? Can I get any?" Yes, indeed you can. Not, perhaps, everything you need. But you can make a start.

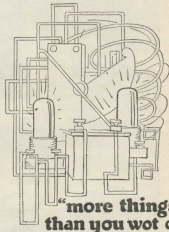

**"more things
than you wot of"**

Since it is pretty generally the fact that receiving sets now in use, yours too very likely, are capable of delivering more power than they do, some of the more enlightened and more progressive tube manufacturers have begun by tackling the neck of the bottle. And that is the last tube, the second audio tube, the tube that delivers the stuff to your loud speaker.

Take a three volt, or one ninety nine set, for example. Your r. f. tubes, and your detector, are functioning beautifully. You plug your head phones into your detector jack and you get splendid quality, and very gratifying DX. Then you plug your head phones into your first audio jack and you get all of that with very nice volume, sometimes too loud for your comfort. When, however, you plug your loud speaker into the last jack you find that there's too much noise. There's volume, but not of music,—of all sorts of racket. So you adjust your dials until you get more satisfactory results. Now, when you have done that, you have either cut down your volume below the point that satisfies you, or you still get distortion.

What's wrong? Simply this, that your last tube is overloaded. It can't handle the load it gets, smoothly. A special tube, built for the purpose, is necessary—a power tube.

The Magnatron DC-120 is one of a few tubes that is built for the last audio socket of that 199 set. It is a 3-volt tube. It has a low amplification constant, so that the swing of the grid

(Continued on page 175)



tune in on this

current as possible, while its amplification constant must be somewhat lower so as to avoid any possibility of distortion under its heavy load. And the second audio tube, handling a still heavier load, should have a still lower impedance and a still lower amplification constant. So many second audio tubes are overlooked in the sets now in use. Yours very likely is. And if you are using ordinary tubes, you either have distortion, or cannot use all the volume the set is capable of, or perhaps a little of each is present.

What other tubes do in specialized circuits we will leave for future discussion because not so many such cir-

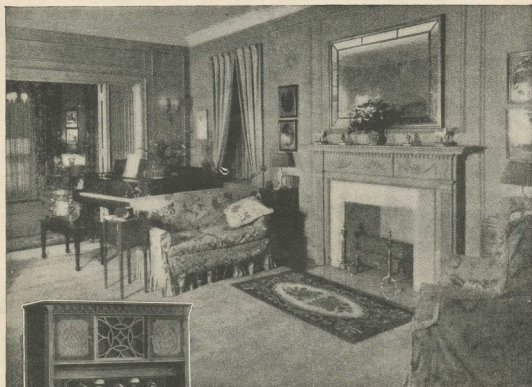

Excello

Radio Console Cabinets

Will add an article of beauty to the furnishings of your home as well as provide an adequate and complete housing for your radio set.

A Complete Line of Stands, Tables, Desks and Consoles

The quality of cabinet work and two-tone finish is of the highest. Excello Cabinets have ample battery space, built-in loud speaker and adjustable filling pieces to accommodate panels of various size.

ASK TO SEE THE EXCELLO AT YOUR DEALERS OR WRITE FOR CATALOG.

EXCELLO PRODUCTS CORPORATION

4821-29 West 16th Street,

Cicero, Illinois (Suburb of Chicago)

Distributors and Dealers: Some attractive territory still available. Write for interesting proposition.

The Counterphase Receiver

By J. T. CARLTON

An Exceptionally Efficient Broadcast Set Employing Toroid Type Coils

THE circuit described herewith is one that has attracted an unusual amount of attention during recent months, and at various radio shows through the country has been hailed as one of the most popular circuits of the season. It is noticeable also for the further reason that it is one of the comparatively few circuits being manufactured at this time that is covered by patents, the same having recently been issued to Harry A. Bremer and assigned to the Bremer-Tully Mfg. Company.

The Counterphase Circuit as designed is particularly adapted for the use of "toroidal" or so-called doughnut coils, the Torostyle transformers used therein also being an item on which the constructional and design features are likewise covered by patents granted to Mr. Bremer a short time ago. Particular mention is made of this toroidal coil for the reason that it differs from any other similar coil on the market, being designed particularly for the Counterphase circuit which makes use of an oscillation control method employing an additional winding.

Oscillation Necessary

As the principles explained herein become better understood the neces-

sity for such method of oscillation control becomes more and more apparent. The elementary principles

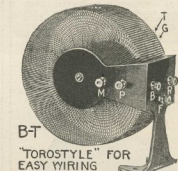

Illustration by Courtesy of Bremer-Tully Mfg. Co., Chicago, Ill.

This is the toroid type of coil used in the Counterphase Receiver. It is especially designed to simplify wiring and to eliminate inductive effects that generate noises in receivers.

two years but with further added refinement made possible thru the development of apparatus which permits greater simplicity of operation and more efficient results.

Selectivity is one of the greatest of present requirements and also the ability to shut out local disturbances. A great aid in accomplishing this ob-

efficiency which would result from the enclosing of the open type of coil.

Counterwise Theory

Theoretically the B-T Counterphase method employs a "bridge" between output and input circuit. Counter potential is derived from a coil inductively coupled to the plate circuit and sent thru an adjustable capacity to a coil inductively coupled to the grid circuit. The use of such coupled coils either as such or when

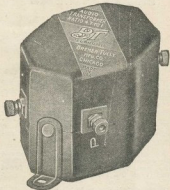

Audio frequency transformer used in the Counterphase Receiver.

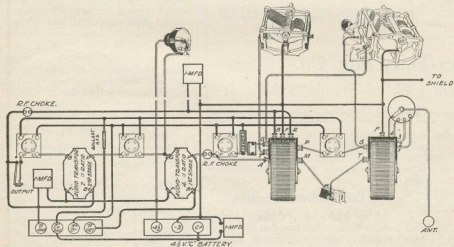

Picture wiring diagram of the Counterphase set.

ject is to be able to fully shield a receiver and the closed style of coil permits shielding without the loss in

used with inductance, resistance or capacity, in series, is covered by the Bremer patents. To secure the greatest results from the use of this method extremely careful design is necessary to avoid such an increase in grid-to-plate capacity as to prevent neutralization at the lower wave lengths. This has been worked out in the Torostyle transformers by the use of the main outside winding as a secondary with an interior supporting member on which is placed a primary winding and also the special or Counterphase winding.

Oscillation control method

The general methods in use for stopping oscillation at this time are

What Everybody Knows

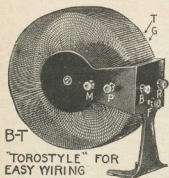

B-T
"TOROSTYLE" FOR
EASY WIRING

3 styles — Antenna Coupler, Intermediate, and 4-circuit ... \$4.00 ea.
5-tube Kits \$25.50
6-tube Kits 38.00

In every line of industry certain names stand for unquestioned reliability and unequalled quality.

Bremer-Tully occupy an unusual distinction — they have never been beaten either on radio parts or circuits in which to use them.

The Torostyle Transformer is a good example of a B-T patented unit designed for a B-T patented circuit — the unequalled COUNTERPHASE.

There is nothing left to chance. Each is designed for the other and turned out by an organization to whom beautiful workmanship is second nature.

The 9-color wiring diagrams leave no room for error. A color for every wire.

We firmly believe that for 4-, 5-, 6-tube sets the Counterphase principle excels any other known — and thousands agree.

:: ::

Instantly Successful

Back of the B-T EUPHONIC Audio Transformer is 20 years of Wire-less and Radio Design.

There's as much difference between the Euphonic and the ordinary machine-shop transformer as there is between a mail-order "fiddle" and a master violin of Stradivarius or Cremona.

No other B-T product ever secured the same immediate national distribution and approval. Unequalled total quality is the reason.

Every high grade dealer carries B-T products. When you buy, buy satisfaction.

:: ::

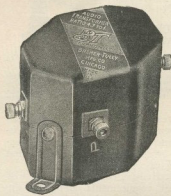

2.2 to 1 \$5.00
4.7 to 1 5.75

"Better Tuning" is a booklet of 64 to 80 pages brim full of Real Radio Information. Read it to get the other side, as well as hook-ups and technical advice.

Postpaid 10 Cents.

Circulars Free.

Bremer-Tully Mfg. Co.

532 S. Canal St.,

Chicago

fairly well known, one of the most simple and common being the addition of sufficient resistance to prevent the possibility of oscillation. The fallacy of such method is at once apparent when we consider the efforts that have been made to reduce losses in coils and condensers.

Among the other methods, those of direct resistances, absorption coils and eddy current losses secured by placing condensers within the field of a coil are more or less generally used in the circuits referred to as "self-neutralizing"; while still another

method is that of slightly detuning or de-resonating the plate circuit by reducing the plate load or number of turns in order to cut down the coupling.

Control Must Be Variable

The weaknesses of these various methods lie in the fact that the energy transfer between tubes is reduced where the coupling is cut down sufficiently to stop oscillation on the lower wave lengths and this same insufficient coupling results in very unsatisfactory response on the longer

waves. In other words, the method answers only for part of the range,— and this brings up immediately the question of a variable control.

It is pretty generally understood that in operating a regenerative set some method is necessary whereby the feed-back is brought just below the point of oscillation. In other words a variable tickler is necessary.

In the Counterphase there is likewise a variable control of oscillation in order to secure the same efficiency on both high and low wave lengths, an opposite method however being used, which prevents or eliminates regeneration instead of producing it.

Dual Resistance Control

The method employed to secure this control is quite ingenious. Consider a condenser with a variable resistance in series. If the resistance is changed the capacity of the circuit is changed without turning the condenser. Now picture two condensers using this common resistance. A variation in the latter will change the capacity of both circuits simultaneously. The condensers in question are the small neutralizing condensers which are first adjusted, after which they can be controlled by means of the resistance knob which at the same time is also used for the other part of the resistance in series with the B battery circuit.

Where it is desirable to cut down volume, sensitivity is not required. Where sensitivity is what we are after we also want as much volume as can be secured. The dual resistance has two separate arms, one of which is always at zero when the other is operating; tuning in one direction increases both sensitivity and volume; turning in the other direction decreases both of them.

There is still further fortunate factor operating to our advantage in the fact that this method does not introduce losses into the grid circuit or interfere with selectivity and in addition to that it does not effect dial readings by detuning the circuit.

External Circuit Great Improvement

It would seem that this solution of using an external circuit designed to feed back energy of opposite potential in such manner and amount as to overcome or break down the regenerative action of the tube is in itself of considerable importance, but when it also adds a surprising increase in the transfer of energy per stage there is a consequent great increase in amplification.

(Continued on page 175)

Notes on Wavetraps

Their Theory, Construction and Method of Operation

WAVE TRAPS aid considerably in the tuning of radio receiving sets that are not inherently selective and in *The Irish Radio Review* an article entitled, "All About Wavetraps" gives many details on the construction of these instruments that will be interesting to everyone. The article follows:

Every serious amateur needs a wave trap sooner or later; and it is for those radio workers who wish to increase the selectivity of their sets that this article has been written.

If it is necessary to write with the strictest degree of truth, it must be said outright that the title of this article is, perhaps, a little in the nature of a misnomer. It would be impossible to write down within the confines of these pages *everything* concerning the theory and working of interference eliminators or wave traps, as they are more commonly and happily called. For one thing, space in this journal, like life, is not exactly unlimited, and again, there are quite a number of things concerning the mathematical theory of wave traps which the radio amateur, and more especially the beginner in the science and pastime of radio, does not ordinarily require to study.

But, nevertheless, it is proposed in these columns to put into a concise form that which may well be called the applied theory of wave traps and rejector circuits, and also to give brief instructions for the making and operation of one of these almost indispensable instruments.

Wave traps are used at the present time simply because in all radio sets there exists a deficiency which has not yet been overcome by radio inventors and scientists. That deficiency is to be seen in the fact that very few practical wireless circuits are really selective in the strictest sense of the term. With an ideally selective receiver, it would be possible to operate the set under the nose, so to speak, of a broadcasting station, and to receive far distant transmissions at will without being "jammed" by the local station. A really selective receiver would pick out a station transmitting on, let us say, a wave length of 500 metres from stations transmitting wave lengths of 495 and 505 metres respectively. But with an ordinary radio set such a feat is impossible, or almost so at any rate, and it is only with the assistance of a care-

fully tuned and operated wave trap that such a feat is placed within the bounds of possibility.

The Fundamental Principle

A wave trap, or an interference eliminator—call it what you will—is

extra inductance and capacity in the aerial circuit of the set, but they all operate the same way, i.e., by absorbing the unwanted radio energy from the aerial and by allowing to pass that which is required by the operator.

The extra "rejector" circuit must be

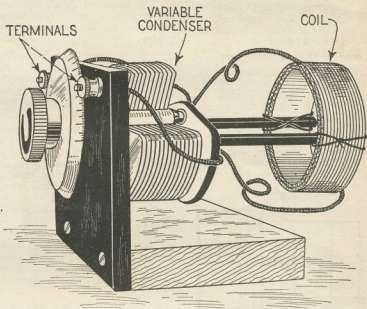

Illustrations by Courtesy of *The Irish Radio Review* (Ireland).

Fig. 3. A simple wave trap for ordinary use in connection with broadcast receivers.

merely a simple little instrument which is attached to a radio set, or else included bodily in its circuit, and by means of which any interfering station can be cut out at will. With an efficient instrument of this type it becomes possible to cut out completely the broadcast from a local station and to receive other and more distant stations. Without the use of a wave trap, it is generally impossible to attain this end, and this characteristic non-selectivity of any ordinary radio circuit is more greatly in evidence the closer the receiver is to the interfering transmitting station.

In theory, all a wave trap consists of is a device by which an extra amount of inductance and capacity in a controllable form can be introduced into the circuit of the receiving set, or, more strictly, into the aerial circuit of the receiving installation. There are many different ways of arranging the

placed in parallel or in series with the aerial circuit of the receiver. This rejector circuit, which comprises the wave trap, is separately tuned, either by altering the amount of its inductance or its capacity, to the wave length of the interfering station, and the interfering signals are absorbed by the trap and passed to earth, whilst the wanted signals are passed on to the set, very little weakened, if any, in strength and initial intensity.

There are two main types of wave trap circuits in use at the present time. The first contains two separate circuits arranged in parallel with the aerial and ground of the receiving set. One of these circuits is tuned slightly above the wave length of the station it is desired to receive; the other is tuned slightly below that wave length. Such a rejector circuit is illustrated in diagram at Fig. 1.

It is somewhat difficult to operate, however, and by far the most simple form of wave trap or rejector circuit is the one which is illustrated at Fig. 2.

This circuit, as will be seen from the diagrammatic illustration, consists of an inductance coil and a variable condenser arranged in parallel, and this arrangement of inductance and condenser is placed in series with the aerial of the receiving set. The amounts of inductance and capacity may be made variable by means of employing a tapped inductance and a variable condenser. Generally speaking, however, it is more practicable, and more efficient, for most purposes, to employ a variable condenser and a fixed coil, the necessary tuning being effected by means of the condenser.

How to Make a Wave Trap

A simple home-made wave trap, working on this principle, is shown in the photograph, Fig. 3. In this instance, it will be noticed that the instrument consists merely of a small panel mounted vertically on a wooden base. The size of the panel is approximately 5 by 3½ inches, while the base measures 5 by 4 inches, the latter being about 1½ inches thick.

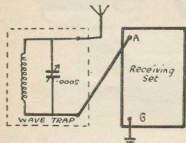

Fig. 2.—Diagram of simple one circuit wave trap showing method of connection to receiving set.

The condenser is mounted on the panel in the usual manner, and two binding posts are provided, one for the aerial lead and the other for the lead to the receiving set.

The matter of mounting the inductance coil in the wave trap is a process of individual preference. The instrument illustrated was constructed in a few moments, and therefore the necessary coil is merely tied on to two projecting strips of metal about two inches in length.

If a very neat wave trap, however, is required, a coil holder may be mounted on the wooden base of the instrument behind the condenser, and the coils will be rapidly and conveniently changeable.

The wiring of the wave trap will readily be followed from a glance at the diagram, Fig. 2, and the mode of attaching the wave trap to the receiving set will also follow from a study of that diagram.

How to Operate the Trap

The wave trap, made as above, is connected up in series with the aerial and the aerial binding post of the receiving set. Before connecting up the wave trap to the set, however, the latter should be tuned as far as possible to the wave length of the signals which it is desired to receive without interference from any local stations. After this end has been attained, attach the trap to the set, and tune the trap by means of the condenser knob to the wave length of the interfering transmission. Finally, de-tune the receiving set. The unwanted signals will now be found to be cut out, and the desired transmission may be tuned in on the receiver.

It is important to note, in passing, that the wave trap is tuned in to the unwanted signals. It thus "accepts" them and passes on the desired signals (to which it is not tuned) to the receiving set.

The operation of the wave trap is simplicity itself. One cannot fail to get good results from its use, and to any radio amateur who has never experienced the freedom from interference which such a simple little instrument affords, the realization of the fact will come as a pleasant surprise.

Points to Note

In order to obtain the best results with any type of wave trap, however, there are several important points which should be carefully borne in mind.

The first of these is that the coil, or coils, which are employed in the wave trap should be composed of thick wire, about No. 20 or, better still, No. 18 D.C.C. wire. This cuts down the resistance losses in the circuit which forms the wave trap, and therefore there is no noticeable decrease in strength of the signals obtained from the receiving set.

It should also be remembered that it is better to have a greater amount of inductance than capacity in the aerial circuit. Accordingly, therefore, it is advisable to make use of the largest coil possible in the wave trap in order that a minimum amount of capacity may be introduced by the condenser.

Generally speaking, for the purpose of eliminating interference from local broadcasting stations, a coil containing about 50 turns of wire gives satisfactory results, although, of course, it is not easy to generalize on this question. The best results will be obtained by employing a coil of such a size that it allows the wave trap to be tuned up to the wave length of the unwanted signals with the minimum amount of capacity from the condenser.

The condenser itself should have a capacity of about .0005 microfarads.

Every connection in the wave trap should be well soldered in position, for it should be remembered that the instrument is placed in series with the aerial of the set, and thus if any energy is absorbed by loose contacts in the trap, the signal strength obtained in the 'phones will be decreased in consequence.

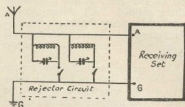

Fig. 1.—A two-circuit wave trap diagram.

Any form of wave trap can, of course, be included in the actual cabinet of a radio set, and in this form it can be put out of action by means of a switch, but, generally speaking, the amateur will generally prefer to construct his wave trap as a separate unit which can be readily attached and detached from the receiving set. By adopting this procedure, many different types of wave traps may be experimented with until the most satisfactory one is found.

But, in conclusion, however, it may be remarked that, for all general purposes, and especially for cutting out local transmissions, a wave trap built on the lines indicated in this article will always afford real satisfaction to the amateur from the threefold point of efficiency, portability and inexpensiveness. A neater and a more handsome instrument may easily be made, but not, for general purposes, a more efficient one.

Every Reader of Radio Review should have these new Radio News Publications

"100 RADIO QUESTIONS AND ANSWERS"

By the Staff of Radio News

"THE RADIO NEWS"

RADIO WRINKLES"

"THE RADIO NEWS"

SUPER-HETERODYNE BOOK"

Each book contains 112 pages, fully illustrated. Large magazine size

Price 50c Each

Sold at All Radio and News Dealers

or Sent Direct on Receipt of Full Price

Experimenter Pub. Co., Inc.

53 Park Place, New York, N. Y.

The Importance of the Loudspeaker for Radio

By S. B. TRAINER*

AS a result of the development of the radio industry which has brought into use radio sets that can receive long distance broadcasting with considerable volume, it has become possible now to use a loud speaker for almost all ordinary radio reception. Ordinary radio reception is now of such volume on a receiving set as to make headphones uncomfortable to use, so that the development of the use of the radio loud speaker has been very fast.

It has been necessary therefore to give greater consideration to the loud speaker as a part of a radio set than ever before and the manufacturers of loud speakers have been engaged in a mass of research work, in order to develop the loud speaker to the point of good radio reproduction where radio broadcasting can be reproduced from a receiving set of a quality to do justice to the excellent sets that are now on the market.

Many points have had to be investigated in connection with the manufacture of loud speakers in order to accomplish the desired results. In order to obtain better radio reproduction, it has been necessary to perfect, not only the reproducing Unit of the loud speaker, but the acoustic part of it, which is commonly called the horn.

The Unit of a loud speaker that will reproduce radio reception well must be so constructed as to meet certain requirements to get proper results. As a loud speaker is naturally bought by the user with a view to long and constant use, it is naturally important that the reproducing Unit, so far as the internal parts are concerned, should be ruggedly constructed and not subject to being put out of order by mishandling. Ruggedness of construction of the Unit therefore is important. As the diaphragm of a loud speaker is the part which activates the air column in the horn to produce sound, it is natural that the diaphragm must be made of a material to receive the impulses from the magnets so as to reproduce in all fineness the variations of the electrical impulses. The size of the diaphragm of a loud speaker Unit is also an important factor, as a diaphragm of the proper thickness and of the proper diameter will produce results superior to the results to

be obtained by the use of a diaphragm of improper thickness and diameter. As the diaphragm reproduces what is transmitted to it from the receiving set through the magnets and pole pieces, the method of fastening the diaphragm in the Unit is a most important factor. When a diaphragm is so held in the Unit as to be permitted to bend from edge to edge and to be allowed to flex freely, greater sensitivity and greater volume and greater clarity of reproduction are the results.

As sound from a loud speaker is produced by varying frequencies or air waves in the air column, it is desirable to have such air waves transmitted through the horn without being affected by cross vibrations of the horn itself.

As the reproducing Unit produces sound by vibrations of the diaphragm, naturally the Unit as a whole vibrates. In order to eliminate interfering vib-

or bell is made of a material which does not naturally vibrate. Either wood or hard rubber or fibre are materials commonly used to obtain this result. By the use of a rubber in-

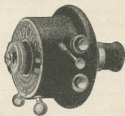

Illustration by courtesy of The Ampion Corporation of America.

A reproducer unit for use in connection with a phonograph.

ulator or bushing between the flare and the elbow of the loud speaker, further interfering vibration or resonance is avoided.

The acoustics of a loud speaker have come to be one of the most important factors that makes the difference between a good loud speaker or radio reproducer and one that is not so good.

Length of air column in relation to the taper of the horn from the small end to the outlet must be scientifically worked out. The relation of the size of the small opening to the size of the large opening of the loud speaker must also be in proportion to the taper of the horn.

From the above it can easily be seen therefore, that the manufacture of a satisfactory loud speaker or radio reproducer must be based upon certain scientific factors which are known to make the difference between a good loud speaker and one not so good. If a loud speaker is constructed so as to embody the various features above described, the user can depend upon getting satisfaction using the loud speaker in connection with his radio set.

Because of the importance of the loud speaker for present day radio reception, those who give attention to the points above described and who, while doing so, employ quality materials and quality workmanship can be expected to have their product popular with radio set users.

(Continued on page 130)

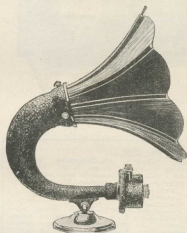

A modern type of loud speaker.

rations of the horn, the best results in sound reproduction can be obtained only by insulating the vibrating Unit or mechanism from the horn of the loud speaker. A common method of doing this is by having a rubber bushing or insulator between the Unit and the small end of the horn. Even this does not overcome the air waves in the horn, causing vibration in the horn and the flare or the bell of the loud speaker. To eliminate this interfering vibration or resonance, the flare

*President, The Ampion Corporation of America.

A Simple But Powerful Toroid Set

By H. K. RANDALL, M. E., in E. E. Assoc., Member I. R. E.

By far the best circuit developed this year are to be found embodied in receivers which are being turned out in complete set form by some of the larger manufacturers. Not all of these manufacturers look with favor on the publication of the circuits they are using, and in some cases these circuits are difficult for the home builder to follow exactly.

Radio Review is, however, enabled to present on this page a circuit which is exactly that used in one of the most interesting of the new sets, the All-American Model R, with the exception of a few changes which we have made, so that the set can be readily built from parts easily obtainable on the market. These slight changes are

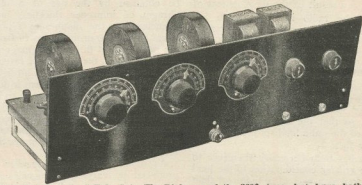

Panel view of the 5-Tube Set. The Dials are of the 300° type, but have both halves of the scale on upper part of dial, for visibility.

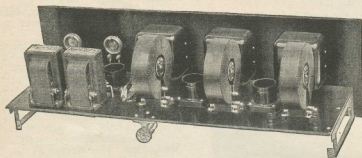

Illustrations by Courtesy of All-American Radio Corp., (Chicago, Ill.)

The rear view brings out the clean-cut appearance, due to the well-shielded condensers and audio transformers, and keeping wires below and close to the sub-panel.

Parts Required for the Set

- | | | | |
|---------------------------------------------------|-----------------------------------------|----------------------------|-------------------------------------------------------------------------------------------------------------------------------------------------------------|
| L1-All-American Toroid
Coil Type T 1. | C2-All-American
Condenser Type C 35. | S-L-F 5 | All-American Sockets,
Type R-25. (These
sockets take either the
regular 201-A or the
"UX" base.) |
| L2-All-American Toroid
Coil Type T 2. | C3-All-American
Condenser Type C 35. | S-L-F | |
| L3-All-American Toroid
Coil Type T 2. | C4-002 Fixed Condenser. | C5-002 Fixed Condenser. | |
| AFT1-Hauland-Lyric
Audio Transformer
R 500. | C6-00025 Fixed Condenser. | C7-1 Mfd. Fixed Condenser. | |
| AFT2-Hauland-Lyric
Audio Transformer
R 500. | C8-002 Fixed Condenser. | R1-6 Ohm Rheostat. | NOTE—When using new
U X Power Tubes break
grid return at points
marked + and insert
"C" battery of voltage
recommended by manufac-
turer. |
| C1-All-American S-L-F
Condenser Type C 35. | R2-6 Ohm Rheostat. | R3-1 Meg. Grid Leak. | |
| | Panel Size 7 x 24" | 5 tubes, 201-A type. | |

not such as to affect the performance of the receiver in any way, and if the set is laid out as indicated on the photographs, and is carefully wired in accordance with the diagram, its performance should equal in every way that of the manufactured set.

There is nothing very unusual in the diagram itself, except the way in which three fixed condensers, shown in the diagram as C4, C5, and C7, are used to by-pass the B battery and attendant wiring. As seen in the diagram, these three condensers are all in parallel with each other. In fact, however, the 1 mfd. condenser C7 is connected across the B battery at a point near the battery terminals, while the .002 condensers are placed so as to run directly from the post on the Toroid Coil marked -F to the -F post on the tube socket. Together with the natural tendency of good Toroid Coils to exclude extraneous signals, these fixed condensers have a remarkable effect in making for quiet and clear reception.

The unusually clean-cut appearance of this set in the photographs is due to the effective use of the sub-panel

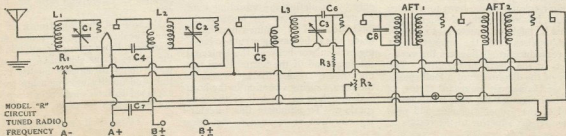

Circuit Used in the new All-American Receiver (Model R)

Straight-Line-Frequency Tuning Without the Brakes!



ALL-AMERICAN Condensers, with their smooth-sliding plates, (see sketch at left) require no tensioning. There is no sensation of raising a weight or letting it fall. Compactness, also, far exceeds that of rotor types. (See dimensions on sketch.) Efficient shielding prevents the touch of the fingers from affecting the tuning, and protects the plates permanently from dust or damage.

Taking full advantage of the 360° rotation, there is an ALL-AMERICAN Dial with two scales, both on the upper half, where they are always visible.

Used with the ALL-AMERICAN Toroid Coils, these Condensers space out equidistant on the dial all wave-frequency channels from 550 meters down even to 175 meters. Power and selectivity are greatly improved through the absence of stray magnetism

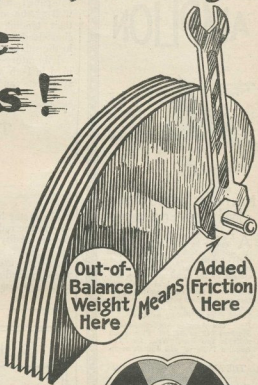

Out-of-Balance Weight Here

Added Friction Here

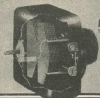
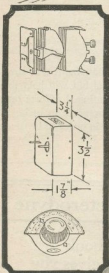

ALL-AMERICAN Straight-Line-Frequency CONDENSERS

Type C-35 Max. 350 micro-microfarads (Min. 10.5 mmf. at 400 meters) ... \$4.50
Type C-50 Max. 500 micro-microfarads (Min. 11.8 mmf. at 400 meters) ... \$5.00
Type C-40, 360° Dial ... 1.00

ALL-AMERICAN
STRAIGHT-LINE-FREQUENCY
TUNING



ALL-AMERICAN TOROID COILS

Type T-1 Antenna Coupler, \$3.50
Type T-2 R.F. Transformer, 3.50
Set of 3 coils complete, ... 10.50
The R. F. Transformer has a small primary, closely coupled to the secondary, entirely air-insulated. The coupler has taps for long and short antenna. All bases are of bakelite.

ALL-AMERICAN
TRADE MARK
Famous Audio
Transformers



Standard Audio
Transformers
3 to 1, R-12, ... \$4.50
5 to 1, R-21, ... 4.75
10 to 1, R-13, ... 4.75

Power Amplifying Transformers
(Push-Pull)
Input Type R-30, ... \$6.00
Output Type R-31, ... 6.00

Rauland-Lyric
A laboratory-grade audio
transformer for music
lovers. R-500, ... \$9.00



ALL-AMERICAN RADIO CORPORATION, 4227 Belmont Avenue, Chicago, Illinois
E. N. Rauland, President

RMA

OWNING AND OPERATING STATION WENR-256 METERS

ALL-AMERICAN

Pioneers in the Radio Industry

AMPLION

Alfred Graham & Co.,
London, England,
Patentees

Its clear tone comes from 38 years of loud speaker experience

ALL who hear The Amplion are won by its clear, life-like tone—the quality which has made it the world's largest selling loud speaker. The explanation is that The Amplion was evolved by the actual originators and oldest producers of loud speakers—nearly forty years experience! Long before radio became popular, their radio speaking devices were in use on over 12,000 ships of leading nations.

Hear The Amplion—in comparison! Speakers \$12 to \$42.50. Phonograph units in two sizes. Write for "The Amplion Pedigree" and dealer's name.

THE AMPLION CORPORATION OF AMERICA
Suite J, 280 Madison Ave., New York City
Burnside of Canada, Ltd., Toronto

construction, with parts of a type suited to it. The sockets have their binding posts inverted so that filament wiring is all brought underneath the sub-panel, and the Toroid Coils as well as the audio transformers have their binding posts so placed that short leads can be run through holes in the sub-panel.

Laboratory-grade transformers are used in both audio stages. These instruments can be relied on to give tone

quality not exceeded by any other type of coupling, and five tubes in this kind of a set may therefore be said to do the work of six in sets where a smaller amplification per audio stage is obtained. The condensers used give a strictly straight-line-frequency characteristic with 360° rotation, rendering entirely unnecessary the use of any vernier mechanism, and thus simplifying the set still further.

The Importance of the Loudspeaker for Radio

(Continued from page 127)

No factor is quite so important today in the radio field as the need for better quality and better workmanship.

If radio users will insist upon buying only loud speakers of known merit and high quality, they will not only

obtain greater satisfaction in the use of loud speakers but will help to encourage the continued efforts on the part of manufacturers to make their products better in order to be successful in business.

Build Your Own Super-Heterodyne

Here's a book that gives you all information

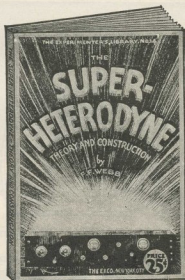

This is the big book of instruction and information on the various standard "supers" in common use today; a complete, up-to-the-minute, impartial 64-page book covering all the builder or user of this type of set might want to know. The Super-Heterodyne is written by a radio authority who not only has years of trade and practical experience but is constantly designing modern radio apparatus. It is a handy, useful size, 5½ x 7½ inches, printed clearly, profusely illustrated, easy to read and bound with a handsome two-color cover. This is the very latest of the complete library of Experimenters' Handbooks on radio. These books are complete practical guides to almost every important phase of radio transmission and reception.

Price 25c

SOLD BY ALL RADIO AND NEWS DEALERS

Published and Distributed by
The Conrad Co., Inc.

Sole distributors for the E. I. COMPANY
64 Church St., New York, N. Y.

Are You the Man ?

to be first in your town to sell and demonstrate **POWEROLA**, the famous 3-tube, **NO-BATTERY**, **ELECTRIC LIGHT SOCKET RADIO RECEIVER** (not an attachment, universal for D.C. or A.C., 110-115 v., 40-60 cycles), now sold and demonstrated thru **THE NEW YORK EDISON CO.**, public utility companies and radio, electric and music stores everywhere. Absolutely dependable, fully guaranteed, powerful, practical, perfect in performance.

Trusted and endorsed by Popular Radio, Radio Broadcast, Radio News, and all leading authorities and engineers of your local electric light company.

Are You the Man Who Sees Opportunities Ahead for Real Money Making?

You Too Can Make Powerola

Send \$1.00 for wiring diagrams showing how to re-wire any old or new party, battery sets or radio circuits (one to eight tubes) and power connections used, to operate satisfactorily from A.C. or D.C. Get in at once on wonderful and exclusive business. Thousands of homes are waiting for you now.

Write for literature, terms and prices at once.

POWEROLA RADIO CORP.
Dept. R.R. 1845 Broadway, N. Y. City

RADIO BARGAINS

FREE RADIO CATALOG & GUIDE of newest ideas, over 100 approved special loud-speakers with illustrations. Tremendous savings on standard radio-parts, sets, kits. Be sure to get this charity book before you buy. Wonderful! Tomorrow! You'll see us. Write letter or postal NOW. **BARAWIK CO.**, 152-152 S. Canal St., CHICAGO, U.S.A.

How to Solder Properly

By P. C. RIPLEY*

IN the construction of a practical and efficient radio receiver, solder is indispensable. It is that substance which binds the mechanical joints of your set, making them impervious to oxidation. Oxides, we know, are the very poorest sort of conductors for electrical energy, and mechanical joint, no matter how secure, cannot prevent the encroachment of our ever present friend oxygen.

That solder is indispensable will, no doubt, be assailed by some; yet, if you will take the trouble to examine sets made by the leading manufacturers and radio engineers of the day, you will find more than 95 per cent rely on solder to protect their joints. Be assured, that if there existed a better method, it would be adopted, and the ratio would be reversed. In a compact radio receiver there exists only a limited amount of space in which to manipulate pliers or other tools to tighten terminals or binding posts, giving rise to the chance for insecure electrical connections. Couple this with the fact that these will in a short time oxidize, you can readily see why a soldered joint is imperative. Regardless of whether you use a flexible, insulated, wire or the more common tinned bus bar, to properly protect your joint or connection



Solid Wire Solder Spool

solder must be used. You, who want distance and the strongest and purest tonal qualities, can readily appreciate the obstacles a few insecure or oxidized connections present to the travel of those feeble radio currents. Do not confuse oxidation with common corrosion or rust—such as you have noted on articles of iron, for the metals of which your radio will be constructed, will not present any such startling evidence of oxidation. Yet, it will be present just the same, offering its resistance to the radio currents.

The mere fact that a radio joint has some solder melted on it, will not be a guarantee that it is a perfect joint for radio conductivity. To be effective,

it must be properly applied and suitable materials must be used in forming it. For the novice to successfully solder, it is essential that he know something of the composition and characteristics of solders and fluxes. Also, as an aid in their application, he should be acquainted with the correct tools and their uses. Soldering, in the minds of many, constitutes an accomplishment akin to the black arts of mediaevalism, but if they will take the pains to secure the correct materials, with a minimum of practice, they will find such is not the case.



Rosin Core Solder Spool

So, for you, who wish to build an efficient radio receiver, it will be advisable to follow the accepted and proven methods of our leading radio authorities by using solder bonded joints.

Solder

Solder is an alloy, composed usually of the two metals, tin and lead. These two metals are combined in variable proportions, which reflect certain well defined characteristics in the alloy, and are a controlling factor in the selection of the solder for specific purposes.

One of the vagaries of nature is manifested in solder, for it possesses a lower melting point than either of its component metals. Other metals may be added which will bring about a further lowering of the melting point; but, in doing this, we effectually destroy some of the desirable attributes ordinary tin and lead mixtures manifest. So, we may at once dismiss from our consideration solders of a lower melting point than are obtainable with tin and lead combinations.

In your purchase of solder, it will be wise to select a product that the manufacturer endorses for radio use, as he has conducted exhaustive experiments to determine the correct proportions of tin and lead which will give you good results. Beware of cheap solders, for, oftentimes, they are made from reclaimed metals, and may con-

tain metals other than tin and lead. These may raise the melting point, render the alloy brittle, detract from its flowing quality, or give an increased resistance to the flow of your delicate electrical currents.

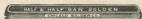

Illustrations by Courtesy of Chicago Solder Co., Chicago, Ill.

Bar Solder

The more common forms in which this commodity is offered for sale are: bars, wire and ribbon. The bars usually weigh from a pound to a pound and a half per bar, and present a form that is not readily adaptable to the uses of the radio set builder. We would not recommend the purchase of solder in this form for the average radio construction. Next, we have solder in the form of a wire, and this type will be found much more convenient to handle than the bar. The ribbon type will probably meet with the approval of every enthusiast, and is a most adaptable form of solder for radio construction. One advantage in the purchase of the wire or ribbon type is, that, it may be secured in smaller amounts when purchasing solder. Both wire and ribbon solder may be purchased which contain their own flux (rosin), and offer a most convenient solution in the procurement of these two essentials for your soldering.

So, the wise procedure for you, who know nothing of solders, is to demand a trade-marked article, made of virgin metals, carrying the manufacturer's endorsement as being suitable for radio use. Then, you will be assured of securing a correctly made article.

Fluxes

Under the heading of fluxes comes one of the most important factors of success or failure in soldering. Flux is that substance, whose duty it is to dissolve the oxides which occur on the surface of the parts to be joined with solder. When these oxides are dissolved, it enables the solder to enter the minute pores of the metal surface, effectually sealing it against the penetration of oxygen.

Fluxes range in character from very strong acids to very mild acid bearing substances. For radio use, we must have a flux which is non-corrosive, and which in its use will leave a residual matter that will have

*Retrask Engineer, Chicago Solder Co.

no tendency to collect moisture, dust or other foreign material. This is imperative. There have been some ineffectual efforts to neutralize the stronger acids and use them, but to do this is to court disaster. Simply because you incorporate alcohol or ammonia in these stronger acids to the point where they appear neutral, does not assure that the residual matter will be neutral after the heat of the soldering operation has driven off the alcohol or ammonia. So, let us, at once, forget the stronger acids as



Rosin Core Solder in roll form.

being entirely unsuited to radio use. Next, we come to the pastes or semi-viscous fluxes, which are another form of compromise in an effort to use the sharp acids. These contain a more or less limited amount of the strong fluxing materials, suspended in some organic grease or wax. The popular idea is, that the presence of these greases, will prevent corrosion on the work. Unfortunately, this is not true, as the acid content of these compounds will corrode even if enveloped in grease, as the heat of the soldering operation does not change their chemical structure. Some manufacturers of these acid bearing pastes, have been so bold as to advertise their wares as being absolutely non-corrosive and adaptable to radio use. This is misleading, and the radio enthusiast should view all pastes with suspicion when purchasing a flux for radio work. Should he care to test the manufacturers' claims regarding the corrosive action, simply heat a small amount of the paste and some solder on a piece of German silver and set aside for thirty days. The result will be startling.

Still another bad feature in the use of paste, is the fact that the organic greases or wax that are universally employed in its manufacture, over-run when heated onto the insulating material of parts and wires. This breaks down or rots these insulations, and will manifest itself in no uncertain manner at a later time. The active acids in these pastes usually have an affinity for moisture; and, as they are deposited in a thin film over your parts in the soldering operation, they will induce dielectric losses. To attempt to remove them with alcohol, simply tends to spread them over a

greater area, often into the parts themselves. Grease also forms a very efficient collecting agency for dust and foreign matter, which may bring about still further losses through leakage of these radio currents.

The leading manufacturers and radio engineers have spent large sums in experimental work, and have conducted exhaustive tests to determine the best flux for radio use; and, they are almost unanimous in acclaiming rosin the safe and sure radio flux. Contrary to popular belief, rosin is acid—or rather contains acid in its natural structure; yet, its physical characteristics are such, that, it is non-corrosive in action. Rosin is a rather complex mixture of a number of different substances, and these undergo certain changes when subjected to heat, light, age and atmospheric contact. The action of these forces will materially alter, or destroy entirely, the good fluxing qualities of a rosin. The United States Department of Agriculture recognize some twelve standard grades of rosin. Of these, there are only a few which have the necessary qualities to make them efficient fluxes. This of course, presents a problem to the novice in the selection of a rosin which will serve as a flux.

Here is where a rosin-cored solder will lead the way out of the difficulty. The manufacturer of this solder, in



Phantom View, and Description

either the ribbon or wire type, carefully tests all rosins which enter into his solder, and uses every precaution to maintain and insure the retention of its highest fluxing qualities. Should the radio enthusiast purchase bulk rosin, he must remember that age is detrimental and should demand fresh rosin. Also, that the darker grades are the least active as fluxes.

Now, to enumerate the distinct advantages of rosin as a flux, they are briefly these: Non-corrosive and the residual matter exhibiting no tendency to gather moisture, dust, or foreign substances; and, if proper grade is used, and while not quite as rapid in action as the stronger acids, it will prove to be a very efficient fluxing material.

Selection of Tools

In the selection of tools with which to transmit heat to the work to be soldered, we have three, more or less, distinct types as follows: A torch

throwing an open flame, the conventional type of soldering iron which absorbs heat from some source and acts as a conveying agent to the object to be soldered and the electrically heated iron.

The torch is more or less impractical, as it is too hard to confine the flame to the area to be soldered without damage to the surrounding parts. Also, it produces excessive oxidation and is apt to carbonize the work as well, unless it is operated by an experienced operator.

The ordinary iron, with which we are all more or less familiar, offers the most inexpensive and efficient means of heating our work. For the set builder, who has only an occasional use for a soldering tool, we will recommend this type of iron.

An electrically heated iron has the advantage of holding a more or less constant heat, but its initial cost is considerably higher than the ordinary type of iron. Those of you who care to invest in one of these, will find that you possess a very handy tool. There are electrically heated irons on the market today that fail to generate enough heat for the heavier soldering, and we want to caution you to be sure that in purchasing you secure one of ample capacity. This, too, will apply in the purchase of an iron of the ordinary type.

A long or slender point on an iron must be avoided, as it will not transmit the heat with enough rapidity to give good soldering results. Failures in soldering where a good solder and flux are used, are often traced to the lack of heat in the object to be soldered, thereby, failing to allow the solder to flow properly.

So regardless of what type tool you employ, the prime factor in securing a properly soldered radio joint is to bring the work to a temperature where it will melt solder itself.

Application of Solder, Flux and Tools

Now, we come to the application of our solder and flux with the aid of our soldering tools and skill. If we will bear in mind this one very important fact, we cannot fail to accomplish a perfectly solder bonded joint; and, that is, *our work must be hot enough to flow solder.*

First, let us give some serious attention to our iron shape as this has a very important bearing, also, it seldom is given much consideration by one not experienced in the use of solders. In the following illustrations Fig. 1 shows a correctly shaped iron point, while the one in Fig. 2 should be avoided.

The iron in Fig. 1 having a more or less blunt point, will present a maxi-

KESTER *Radio* SOLDER

(Rosin Core)

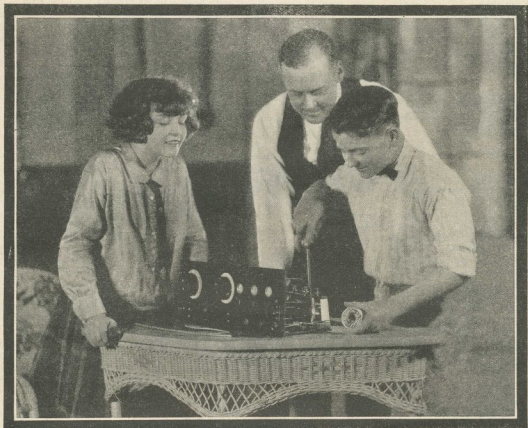

Oh boy!

It Sure is Safe and Simple

"Requires Only Heat"



*Approved by
Radio Engineers*

IF YOUR DEALER CANNOT SUPPLY YOU

Chicago Solder Company

4252 Weighwood Ave., Chicago, Ill.

Gentlemen: Send me one can Kester Radio Solder, for which I enclose 25c in stamps.
(Postpaid anywhere in U. S. A.)

Name.....

Address.....

City..... State.....

Dealer.....

imum of surface to the work through which it can deliver its heat and bring about a suitable temperature in the object to be soldered, before radiation has come to carry the heat away. The iron in Fig. 2 with its longer and slenderer point, will only make a limited contact with the work, and radiation may be so rapid as to defeat our object of heating the work to a solder melting temperature. The result will be an insecurely soldered joint, and what is commonly termed, a rosin joint.



Fig. 1.

After we have secured a properly shaped point, we must next see that it is solder coated to prevent the formation of oxide on its working faces. Oxides not only being bad electrical conductors, are also poor conductors of heat, and their presence on the working faces of our iron may defeat our efforts to heat our work properly. When solder is coated or tinned, the solder has a tendency to web between the iron face and the work, and will take care of the irregular surface of either. This assures us of a maximum contact for the flow of our heat. To secure this solder coating, heat the iron; and, with a file, smooth the faces. When you have removed all of the oxides, and the metal shows that it is clean and bright, apply your rosin-core solder to the faces until they are coated. Should your iron later become overheated and this film of solder destroyed or oxidized you will observe, that it loses its efficiency in heat transmission. Before attempting to use it further, it will be necessary to renew this film of solder, following the method outlined above.

Next, let us consider the proper handling of our iron. We must bring it in contact with the work in such a manner that a maximum of surface is presented for heat transmission. Fig. 3 illustrates a correct contact, while Fig. 4 shows a poor one.

In Fig. 3 the iron face lies flat on the work, giving a maximum contact for the flow of its heat. In Fig. 4 only the extreme point of the iron is in contact. This limited contact cannot allow for a great enough flow of heat to overcome the radiation in the work. So, remember, we must give the iron a chance to transmit the heat that is stored up in it, to the work, by bringing in contact all of the face surface our work will permit.

When applying solder and flux to the article to be soldered, the flux must come in actual contact with the

joint or object to be soldered. The sole reason for the flux is to dissolve the oxide film that is on the surface of the work, and if we destroy our flux before we have accomplished the soldering operation, we are certain to fail in securing a well soldered joint. Now, rosin is disintegrated with heat, so you see there is a time limit which must not be overlooked in applying our flux and solder. Do not apply solder and flux to the iron; apply it directly to the work after it has attained a temperature where it will melt the solder. We are not interested in melting solder and flux on the iron; what we want is a securely soldered piece of work, and the easiest way to secure this is to apply the solder and flux directly to the heated joint. If the work is of a nature that demands we carry our flux and solder to the work on our iron, let us so arrange it, that a minimum of time elapses between the picking up of these and their application to the work. When melting these onto the iron, be sure that



Fig. 2.

the iron point is directed more or less downward, so that, they will have no tendency to run up the body of the iron. Both flux and solder must be concentrated at the point in order to

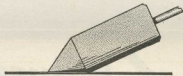

Fig. 3.

secure the best results. Also, instead of picking the solder off the coil with an upward stroke, do this with a downward stroke; and, then, your rosin will not have to run around the entire point to get to the bottom face where we must have it. As a suggestion to the set builder, we would discourage this as being more or less impractical. However, if he wishes to use this method, let him first do a little practicing and carefully note the action in this method. Take a scrap of tin or copper, and with a hot iron try carrying the flux and solder from your spool of rosin-core solder. You will note that the instant the solder and flux have melted onto your iron, a film of white smoke is produced. Your rosin has started to disintegrate, and when this stops, you will find that the residual matter on the iron possesses no fluxing power at all. So, if you wish to use this method, you must

get your solder and flux to the work before disintegration is complete.

Next, try heating the scrap of metal with the iron, and as soon as it reaches a temperature where it will melt solder, apply your rosin-core solder directly to the work at the point of its contact with the iron. Do not remove the iron from the work until the solder has spread out evenly and smoothly. After a little practice with this method, make a comparison of the two methods outlined and you can readily see the merit of applying the solder and flux directly to the joint.

Still another method, which we would suggest as a substitute for the first one mentioned, would be to tin or solder coat the two parts to be joined at their point of contact. Then, bring the two solder coated surfaces in contact with each other, and apply the iron until enough heat is transmitted to knit, or flow, the two together. There is usually enough rosin clinging to the surfaces to successfully flux the operation.

Parts presenting nickel-plated or brass soldering contacts, should be avoided as much as possible, as the oxides of these metals do not respond to rosin flux readily. In the case of nickel-plating, this may be removed with a file, and then, you will find that the base metal will solder much easier. Should it be necessary to solder on these metals, remember, that it will require a great deal of patience to make a good joint. Often, you will be presented with the problem of soldering enameled, lacquered or rubber insulated wires. Before making any attempt at soldering these, we must first clean them thoroughly. In the case of the enameled or lacquered wires, all that is necessary is to scrape or sandpaper until all the covering material is removed, and the surface is bright and clean. For rubber insulation, simply cut this away and treat as you did the enameled wires.

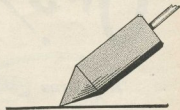

Fig. 4.

Another point which might be well to bear in mind is the activity of copper as a conductor for heat. This metal is one of the best heat conductors we have; and, as the wiring of our radio receivers is always of this metal, we must take into consideration the greater, proportionate amount of heat we must apply to overcome radiation.

Variable Resistance in Radio Circuits

By ARNOLD E. PFEIFFER

SO common is the knowledge that resistance in radio circuits makes for inefficiency that even the rankest layman has learned to scrape the end of his aerial lead-in before connecting it to the set, but the rankest layman has yet to learn that resistance, properly applied, will also increase the efficiency of a receiver. Resistance in radio circuits is altogether undesirable, in certain parts of circuits, in other parts it is indispensable.

Take, for example, the condition known as distortion, the condition that manifests itself in slurred words and ragged music and which is characteristic of almost every commercial receiver on the market today. Resistance will remedy that!

Radio set manufacturers—excepting those that make extremely expensive sets—do not, for some unaccountable reason, incorporate in their sets certain refinements that would add greatly to the fidelity of reproduction, and which would enable you to hear the broadcast offering in all the beauty of its original delivery—not the way you hear it now, often distorted to frightfulness. And as the set manufacturers do not take the trouble to add these refinements, it is our purpose in this article to tell you how to do it yourself, so that you, too, may enjoy to the fullest extent the art that stands alone in its possibilities for pleasure and entertainment.

see two devices called "audio frequency transformers." They are easily distinguishable from the other apparatus in the set because of the large iron cores which are a part of them. These audio frequency transformers function in the circuit to step up the signal strength after the signal is detected or rectified by the detector, and therein lies the trouble. Set manufacturers use this system of amplifying the signal to loud speaker proportions for no other reason than that it is the cheapest and because every other set manufacturer uses it! The system is all wrong.

Transformer coupled audio frequency amplification, when carried

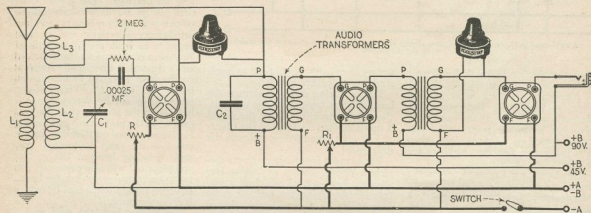

Wiring diagram showing Chlostrats shunted across the tickler and the secondary of the last audio frequency transformer.

Take the condition known as "squealing" in tuned R.F. circuits, a condition caused by the tubes becoming saturated as frequency resonance is approached, and which drives the listener-in frantic because he can't clear the signal. Resistance will remedy that!

How often have you felt that you could get a louder and clearer signal from your three-circuit tuner if only it would not "plop" in self-oscillation so suddenly, if only it were possible to approach the "spilling-over" point more gradually. Resistance will remedy that!

One could fill pages with the ills of radio that can be remedied by the proper application of resistance, but the three subjects mentioned are those most common and most likely to be encountered. Let us, to begin, consider the subject of distortion.

The First Requisite

Does any one take issue to the statement that the first and prime requisite of a radio set should be the fidelity with which it reproduces broadcast song, speech and music? I think not. Hunting for distant stations is fascinating, hair splitting selectivity is desirable, but after all a set's ability to reproduce music clearly and without distortion is the greater achievement. Kings and emperors of a generation ago had not at their command the singers, the orators, the musicians and the entertainment that the average American has today at the flip of a dial. These singers, orators, musicians and all the host who serve you, serve you to the best of their ability—why should you not hear them from a set that does justice to their efforts?

If you look into your set you will

through to two stages, cannot give distortionless reproduction, because transformers amplify some frequencies to a greater degree than others. One stage of transformer coupled amplification, however, will not distort, or rather its distortion will not be audible to the average unpracticed ear, but where amplification is carried through to two stages, the distortion produced by the first transformer, little as it is, will be built up to greater proportions by the second, owing to the increased distorting qualities of successive stages of transformer amplification.

Suggesting a Remedy

How are we going to remedy the matter? We can, of course, rip out the last transformer and substitute two stages of resistance or one of impedance

coupling—two stages would be necessary for sufficient volume—but not only would this entail considerable expenditure of time and effort and a knowledge of wiring not possessed by the average person, there is also the possibility that lack of space in your set precludes incorporating another tube. Also, if you substitute resistance coupling, it would be necessary for you to employ just double the "B" battery voltage you are now using.

These radical changes, however, are not at all necessary. It will surprise you how simply and effectively your set can be changed from one that gives

a hundredfold for the small expenditure necessary.

Obtain a Clarostat, and either a phone cord or a few feet of double conductor lamp cord. Attach one set of terminals of the cord to the spring clips of the Clarostat. Slip the other end of the cord through one of the holes in the back of the cabinet. Raise the cover of the set and determine which transformer is nearest the hole admitting the cord. Connect one terminal of the cord to the post marked "G" and the other terminal to the post marked "F," or if one side of the transformer is simply marked "sec-

will function properly on all broadcast wave-lengths, favoring none, without the aid of a supplementary tuning device. All in all, the transformer method is generally considered inefficient, principally for reasons which will be given later in the part of this article devoted to the control of oscillations by the grid bias or potentiometer method.

In the conventional and popular tuned radio frequency receiver the successive stages are tuned and amplified by either a variable inductance or a fixed inductance tuned by a varying capacity or variable condenser. Of the two the latter system is most widely in favor, and it is upon this that we shall concentrate our attention.

Radio frequency amplification is effected, in tuned radio frequency circuits by tuning the antenna circuit to the desired frequency and succeeding circuits to the same frequency, making a narrow path for the desired frequency to reach the detector, to the exclusion of other frequencies, and at the same time amplifying it considerably on the way. The system is efficient, in so far as we have attained efficiency in radio receivers, admits of satisfactory selectivity and is highly sensitive to weak and distant signals. But there never was an ointment without a fly, and in tuned radio frequency receivers we have the fly of self-oscillation, or "squeals." This self-oscillation is caused by energy being fed back from the plate of the tube to the grid when the grid circuit and the plate circuit are tuned so that they are resonant to the same frequency. Magnetic coupling between the grid coil and plate coil will also cause self-oscillation on certain wave-lengths, but this has been largely minimized by mechanical development.

By tuning both the grid and the plate circuit to the frequency of the incoming signal we would get maximum amplification were it not for the fact that self-oscillation takes place considerably before frequency resonance and maximum amplification are effected. Therefore it is necessary for us to sacrifice a considerable degree of amplification which we would otherwise obtain in order to prevent self-oscillation, which causes the tonal quality of the signal to suffer.

There are several ways of overcoming this tendency to self-oscillation, though no matter what method is used it has the effect of limiting amplification, some methods to a greater degree than others. The oldest scheme is that which employs a potentiometer in the grid circuits of the tubes, where it functions by introducing losses. The system is inefficient, however, because the applied potential on the grids of the tubes changes with the frequency or wave-length, whereas the applied potential should always be constant in

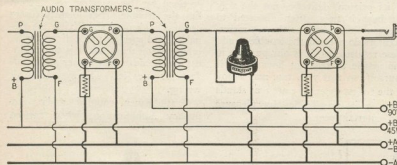

A two-stage audio frequency amplifier circuit showing how the transformers are matched with the Clarostat.

poor reproduction to one that will rank with the best. The simple addition of a Clarostat, together with a few minutes' time, will end your distortion troubles, and at the same time give you a volume control that will stand in good stead late at night, when it is imperative that the neighbors are not disturbed.

By shunting a Clarostat across the secondary of either audio frequency transformer, we obtain, in effect, a stage of impedance coupling, but with this difference. It would be extremely difficult for the average layman to adjust a stage of conventional impedance coupling, *i.e.*, a choke coil and grid leak, to the point of maximum amplification, and even were it so adjusted, volume from the combination of transformer and coupler would not give sufficient volume for our purpose. This is true because impedance coupling, like resistance coupling, is equal only to the amplification factor of the tube used, there being no step-up action as in transformer coupling.

However, we may, through the agency of a Clarostat, obtain not only distortionless reproduction of all voice frequencies, but sufficient volume as well, because by adjusting the Clarostat to the proper point we are able to strike a balance where all distortion is eliminated and at the same time preserve some of the step-up value of the transformer. The Clarostat can be added to your set without disturbing or disconnecting a single wire, and the benefits to be derived will repay you

ondary," connect from post to post. And that's all there is to it!

Before tuning in a signal turn the knob of the Clarostat all the way out, that is, to the left. After the signal is tuned in, turn the knob of the Clarostat slowly to the reverse, and note the difference!

Tuned radio frequency receivers employ a circuit known as "radio frequency amplification," which is a system of amplifying the high or radio frequencies to a considerable degree before they are changed to the lower or audio (audible) frequencies. The radio frequencies can be amplified in two ways, by the untuned interstage method and by the tuned interstage method. The only untuned methods are those employing interstage resistance coupling or interstage impedance and resistance coupling, both of which are inefficient and unsatisfactory on broadcast wave-lengths because of the internal capacity existing in vacuum tubes, especially those of American make, between grid and filament and plate and filament.

It is the contention of some that radio frequency amplification by the interstage transformer method is also in the category of untuned systems, but this contention can hardly merit credence in light of the facts involved. A potentiometer is absolutely necessary to the proper functioning of this system of amplification, and this potentiometer is the tuning device in the system. A radio frequency transformer has not yet been designed that

amplifier circuits. Also its adjustment is critical and in some forms it broadens the tuning considerably.

Another method, and one in popular favor, is that which neutralizes the capacity existing between the grid and plate of the tube, thus preventing the feed-back which produces self-oscillation. There are several ways of doing this—the Hazeltine method, the Rice method and the superdyne method. The last employs a reversed tickler arrangement that feeds back counted E. M. F. to the grid circuit, offsetting the E. M. F. fed back through the internal capacity of the tube. This system, however, is very unstable and difficult to tune.

The Hazeltine system is basically the same as the superdyne, differing only in application, in that counter E. M. F. is generated to balance and neutralize the E. M. F. that feeds back through the capacity of the tube when tuning approaches resonance. In the neutrodyne or Hazeltine system the means for feeding back this counted E. M. F. is fixed, and therein lies its disadvantage. The tendency to self-oscillation is more pronounced on the lower wave-lengths than on the high, and it therefore becomes evident that a circuit adjusted down to favor the low wave-lengths in the matter of self-oscillation will certainly not do justice to the reception of high wave-lengths.

And so we must find an efficient means that can be used to limit the radio frequency voltage that builds up in the plate circuit and avoid the feed-back through the capacity of the tube, which causes oscillation. A most effective way of doing this, and a way that is rapidly coming into favor, is by controlling the tendency to oscillation by a variable resistance in the plate circuits of the radio frequency tubes,

CLAROSTAT

The Greatest Variable Resistor In the World!!!!

A RANGE OF FROM PRACTICALLY ZERO TO 5,000,000 OHMS.

(Ten times greater than that of any other variable resistor.)

A CARRYING CAPACITY OF 200 MILLIAMPERES.

(Ten times more than that guaranteed by any other manufacturer.)

WILL ELIMINATE NOISE AND DISTORTION IN YOUR SET and enable you to receive voice and music reproduced so beautifully that you will marvel.

WILL ELIMINATE SQUEALING, HOWLS, AND INSTABILITY and enable you to pull in distant stations with your 3 tube set that you never knew existed.

WILL GIVE YOU THE GREATEST POSSIBLE RANGE OF REGENERATION when connected across the tickler of your three tube set.



CLAROTUNER

A new three circuit tuner built around the Clarostat and making use of the principle of having the tickler fixed and resistance controlled. Greatly superior to the old style of rotating tickler three circuit tuners because the tickler is always in maximum inductive relation to the secondary, and because the resistance control affords a more even approach to the "spilling over" point. Louder, clearer, and more distant signals can be pulled in with Clarotuner because it is capable of a HIGHER DEGREE OF AMPLIFICATION.

Model TCH is for straight three circuit hook-ups while Model 2 RK, which is a set of two units comprising an antenna coupler and a regenerative tuner is for circuits employing one stage of tuned R. F. and a regenerative detector such as the Radio Broadcast "Knock-out" and similar receivers.

All of the above is covered in detail in a little booklet which will be sent you upon receipt of 4 cents in stamps.

American Mechanical Laboratories, Inc.
285 North Sixth Street, Brooklyn, N. Y.

the resistance is not in the radio frequency circuit and therefore will not broaden tuning.

It is well at this time to mention a type of tuned radio frequency receiver which sold in such large numbers that it is safe to assume that a very considerable number are in use. That is the type that employs no method of controlling oscillations, depending for stable operation on so-called self-neutralizing coils and upon the radio frequency and detector rheostats. As all who possess one of these receivers will bear witness, they oscillate, and oscillate violently, on the lower wave-lengths. The self-neutralizing coils, although they tend to minimize self-

operation and bringing in those stations that are now obscured by squeals and whistles. If you are the possessor of such a set or any other type of tuned radio frequency receiver that is not giving satisfactory operation use this system for stabilizing operation and you will find a new joy in the greatest of indoor sports. Secure a good variable resistance, one that has a working range of from zero to five million ohms, is mechanically sturdy and one which, once set, will not change its resistance. Get a good one or get none at all. The writer uses a Clarostat, and after months of dependable service it still responds nicely to the will of the operator.

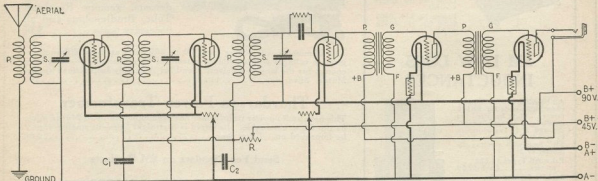

Complete wiring diagram of a five-tube tuned radio frequency receiver employing Clarostat resistance controls.

where it serves to vary the voltage applied to those tubes. When the direct plate voltage is reduced the instantaneous voltage differences between the plate and the grid are reduced, curbing oscillation. As two large by-pass condensers lead the radio frequency current from the primary of the coil back to the negative filament of each tube,

oscillation, do by no means overcome it, and turning down the rheostats to overcome the trouble not only does not help but would be an inefficient way if it did.

It is particularly in sets of this kind that a variable resistance in the plate leads of the radio frequency circuit would aid materially in stabilizing op-

eration and bringing in those stations that are now obscured by squeals and whistles. If you are the possessor of such a set or any other type of tuned radio frequency receiver that is not giving satisfactory operation use this system for stabilizing operation and you will find a new joy in the greatest of indoor sports. Secure a good variable resistance, one that has a working range of from zero to five million ohms, is mechanically sturdy and one which, once set, will not change its resistance. Get a good one or get none at all. The writer uses a Clarostat, and after months of dependable service it still responds nicely to the will of the operator.

(Continued on page 142)

SM SILVER SIX

McMURDO SILVER'S NEWEST RECEIVER

This amazing receiver described in this issue has everything that makes for perfect reception. Thousands of builders report its startling performance—enthusiasm over its marvelous selectivity and sensitivity—marvel at its extraordinary volume. You will find Mr. Silver's description of the "SIX" most interesting. Send for it today.



SM TRANSFORMERS

These are the famous 210 and 211 Silver-Marshall transformers, used in the receivers developed by McMurdo Silver and in several other well known designs. They are contained in the new, attractive bakelite housings, increasing efficiency by 30%! Each transformer supplied with its own curve. Supplied in sets of two 210's and one 211. Each\$8.00

SM SLF CONDENSERS

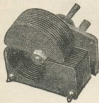

These new condensers are particularly adapted for short-wave reception because of their extremely low dielectric and eddy current losses. They are the smallest S L F Condensers made. Supplied with special attachment for single control.

Prices: No. 310, .0005 \$6.00, No. 311 .0003 \$5.75.

SM LOW LOSS INDUCTANCES

All-bakelite, low loss, interchangeable coils for 50-500 meters. May be used as oscillators, antenna adapters and R F Transformers in standard circuits. Each 3 1/4" long with winding diameter of 2".

Price All Types 50-600 meters Each \$2.50
Sockets for any size coils Each 1.00



SM VERNIER DIALS

The SM Type 801 Vernier Dials are of all bakelite construction. Zero to 100—clockwise—counter-clockwise or 360 degrees (for Remler Condensers) in a single type. In appearance and operation the SM is the finest vernier dial on the market. Price each\$2.50

Anyone Can Build the "Six"

Type 600 KIT Includes all parts necessary\$53.00
Type 610 KIT Essentials only, including 3 condensers, 3 inductances and 3 inductance sockets.\$27.75

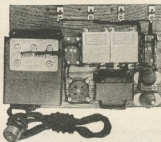

THE IMPROVED RAYTHEON-THORDARSON B-ELIMINATOR

The SM Type 650 Kit includes Thordarson Transformer, choke, Tobe Condensers, genuine Raytheon Tube, Bradleymoans and all necessary parts\$34

This Eliminator will deliver from 20 to 200 volts at three different adjustable voltages with maximum current of 50 milliamperes—more than enough for the largest receiver. Send for Assembly Instructions by McMurdo Silver10c

Thordarson Power Transformer

This new, audio power transformer has been endorsed by McMurdo Silver as the finest obtainable. Its curve is a straight line—its quality cannot be improved on. Price each\$8.00

Send For Circulars on SM Products

SEE THEM AT YOUR DEALERS

SILVER-MARSHALL,
(Incorporated)
105C South Wabash Avenue,
CHICAGO

How to Build the Silver Six

By McMURDO SILVER, A.I.R.E.

FOR some time past, the writer has felt that it should be possible to design a radio receiver possessing all of the valuable features of the best super-heterodynes, yet going a step beyond by dealing with the present season's radio problems in a manner not possible with any previous systems, since none of the present aggravated reception conditions were even imagined during the past year.

Last year about this time, the entire range of available broadcasting channels may have been occupied by transmitting stations, but any listener of a

running up to several thousand meters. Of what value, then, is last year's receiver, with its satisfactory operating range generally from 1330 to 520 kc. (225 to 575 meters)? This year's, and future years' sets must be capable of covering a wide wavelength range—far wider than any existing sets will cover.

The receiver to be described made its initial bow to the radio public thru the columns of *Radio Broadcast* magazine during the fall of 1925 under the title of "A 1926 Receiver." Of it, Arthur H. Lynch, Editor said: "It has

inductances for different wavelength bands. This made necessary the designing of interchangeable coil forms possessing a form factor suitable for all frequencies to be handled. For the higher frequency bands, the turns are spaced, while on coils for waves longer than the present broadcast band, the turns may be bank wound. Six contacts are provided on a reinforced ring at the bottom of each coil upon which are mounted six studs in which the ends of the windings terminate, and which in turn make contact with springs in a special six-con-

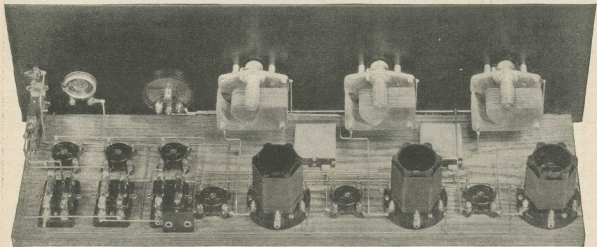

A back panel view of the Silver Six showing how the parts are mounted on the panel baseboard.

year's standing knows that in actual operation this was not so. Channels could often be found where stations were not transmitting and it was seldom indeed that a fan could pick up the full quota of approximately 95 stations that would be required to fill properly the broadcast wavelength range of 200 to 546 meters, a range of some 950 kilocycles. Obviously, there are far more stations operating simultaneously than there were last year. Equally obviously, we require far more selective receivers this year than last.

Today the range of the broadcast frequencies is from 1500 to 551 kc. (200-546 meters). Rebroadcasting goes down to 5996 kc. in some cases, and it is quite possible that the regular broadcasting range may be extended below 1500 kc. (200 meters). Foreign super power broadcasting takes place in many instances on long waves,

well nigh perfect selectivity." This comment is most gratifying, as in designing the receiver but two aims were in view—super-heterodyne sensitivity and selectivity, and the finest quality obtainable from any receiver.

At first glance, the set does not seem at all original, since it consists merely of two stages of tuned radio frequency amplification, followed by a detector tube and two audio amplifiers. The circuit is a combination of the best points of all receivers, carefully executed with regard for the most recent discoveries, and the fund of information gained by the writer and his assistants through contact with many thousands of experimentors—men whose judgment of receiving equipment was based solely upon one thing, performance.

Since one of the first requirements was wavelength flexibility, it was necessary to devise a method of shifting

tact socket, so keyed that a coil cannot be inserted incorrectly. It is order to change a wavelength band, it is necessary only to remove the coils from their sockets and insert ones of different inductance values—an operation consuming about 10 seconds.

The condensers used with these inductances are of the type giving an approximately straight line frequency variation, or a uniform kilocycle variation for each dial division.

Neutralization and Loss of Sensitivity

Neutralization, which is nothing more than fixed oscillation or regeneration control, could not be used. This is because the r. f. amplifier, for a given frequency band, would have to be neutralized at the shortest wave to be received in that band so that the amplifier would not oscillate. Sensitivity would be obtained then only

at the lower end of the wavelength band, while the receiver would be as inefficient and as little sensitive as the average neutrodyne at the longer waves. In this connection, the now popular circuits employing a stage of tuned neutralized r. f. amplification and a regenerative detector were considered. In them, due to reaction, regeneration in the detector circuit tends

distance is so far in excess of this that selectivity is not affected. Due to careful design of the circuit, it is only necessary to decrease the value of shunt resistance to not less than 300,000 ohms to get excellent oscillation control. Obviously, this method will not affect selectivity to the detrimental extent that any other method would.

Single, Double, or Triple Control

The receiver may be tuned either as a single, double or triple control outfit at will. Each condenser is provided with a policy collar, on its shaft, which may be connected with all the others by means of fish-line. This season this method of control will be found on the Bosch, Grebe and Zenith

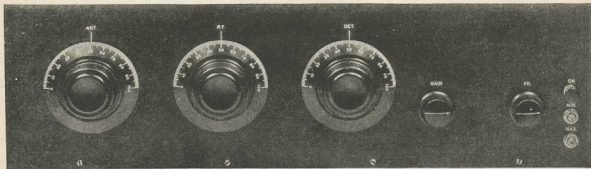

How the front of panel appears. The three large dials are used for tuning while the two knobs at the right are the rheostat and potentiometer.

to assist the neutralized r. f. amplifier. This being at best an indirect solution of the problem, the r. f. amplifier in this design was made highly regenerative, with an increase in sensitivity, since a much stronger signal could then be delivered to the detector tube, the efficiency of which varies with the square of the applied voltage. This means that, with a given signal applied to the detector, doubling the strength of the signal will increase the detector response four times. In the new receiver, due to reaction, the detector circuit is rendered practically as sensitive as if direct regeneration were employed, through the reactive effect of regeneration in the r. f. amplifier.

New Regenerating Control

The actual method of regeneration control employed is now, practically, and consists of a variable high resistance in shunt with the grid circuit of the second r. f. tube. Customarily, a grid biasing potentiometer is employed which is extremely inefficient at short waves although satisfactory at long waves as in a super-heterodyne; or a series B battery resistance. The latter, the most popular method, is extremely unsatisfactory, as it merely controls oscillation by reducing the effective amplifier plate voltage. This process is bound to detune the set in a measure, as well as throw the amplifier tubes entirely off their proper operating characteristic if a C battery is employed, as should be done. In the system used, a variable resistance of 500,000 ohms is shunted across the tuned circuit feeding into the second tube's grid circuit. The probable average operating resistance of the tube is about 150,000 ohms, so that the re-

ceivers, not to mention others. It is, to the writer's mind, the most practical single-control scheme yet devised, because of its flexibility. Thus, the builder of a set may test it out carefully, determine just how it logs, then put the fish-line in place and realize a true uni-control set without the fear that all the circuits may not be properly adjusted, as in the case of gang condensers. The use of external compensating capacities, often suggested with gang condensers, is not particularly to be recommended.

The Audio Amplifier

Three stages or resistance coupled audio amplification are responsible for a fidelity of reproduction which cannot be improved upon. Not only is this method of amplification economical in initial as well as upkeep cost, but the volume obtained is greater than that resulting from the use of a standard two stage transformer amplifier, with loss B battery consumption.

The current consumption of the receiver is astonishingly low. With six tubes, three in the resistance amplifier operating on 135 volts, it was but seven milliamperes as against the general 15 to 25 for neutrodyne and 15 to 40 for supers. Despite the fact that storage battery tubes were used throughout, this was made possible by biasing the grids $4\frac{1}{2}$ volts negative. Thus, the r. f. amplifiers all have the correct bias for 90 volts; the A. F. tubes for 135 volts while the detector is correct for 90 volts. This practice, unusual in the case of the detector, results in an increase in overall efficiency due to the lower detector input losses, plus the greater handling power for strong signals, unobtainable with the customary grid-condenser-leak method of rectification.

Further, a multiple range, uni-control receiver cannot be built practically. It might be possible to build it for one frequency range, but if coils must be interchanged, the circuits must be compensated for errors that cannot be overcome. This is where the beauty of the fish-line control comes in—it is merely necessary in logging at first to determine how many degrees apart the three dials may run for one set of coils, then when they are used, adjust the dials to this relation and go ahead tuning with but one or two controls as desired, since holding one or two dials with the fingers and turning the other merely causes the fish-line to slip, only to grip tightly again when but one dial is turned alone.

Flexibility

One feature of the set is its flexibility. It may be used on antenna or loop with either only a detector, one r. f. or two r. f. amplifiers. Suppose an antenna is to be used, the antenna coil with its adjustable rotor for maximum selectivity is inserted in the socket at the left end of the set. Then the r. f. coils are put in their sockets

and the antenna and ground connected to posts 1 and 2 of the left or antenna socket. Thus, we have a detector and two r. f. stages. If only one r. f. stage is desired, the first tube is removed together with the antenna coil, with antenna and ground connected to 5 and 6 of the middle socket, and the set tuned with the two right-hand dials. To use only the detector, the antenna and ground leads are moved to the socket nearest the detector, and all tuning is done with the right-hand condenser. If a loop is to be used, the antenna coil is removed, and the loop leads connected to 3 and 6 of the socket from which the coil is removed, depending upon the number of r. f. stages desired. The a. f. amplifier is controlled by jacks, one for the first and one for the second stage. Thus the set may be changed from a three to a six tube set at will. The volume resistance serves as a smooth, even control of loud-speaker volume, by means of which any desired intensity of sound may be obtained at will.

Tubes

But one rheostat is used, which will be correct for either dry cell or storage battery tubes. UX201A tubes with a UX112 are recommended for storage battery use. If the builder wishes to use the best tubes available

a completely shielded seven-tube super capable of cutting side-bands, a neutrodyne and several other types of commercial tuned r. f. sets. The "Super" gave, using a loop, slightly greater sensitivity. This could be made up by attaching a 20-foot wire to the grid side of the loop on the r. f.

set and the r. f. Shielding the r. f. set evened things up. This would never be necessary, however, except where the set was but a few yards from a transmitter.

Then a sample receiver was tested in the Radio Broadcast laboratory at Garden City, Philadelphia was brought

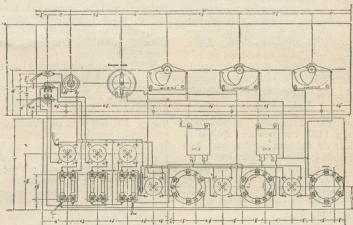

Picture layout and wiring diagram of the Silver Six set.

set. This was seven tubes against five of similar types. The other receivers were practically worthless on a loop. On a 40-foot antenna, the r. f. set and "super" were even—the

in in daylight with plenty of volume to be heard all over the house.

Construction of the Set

To build the receiver, the following material is required. It is suggested that substitution be not indulged in, since many of the items have been designed for the set—to substitute without proper knowledge of the electrical details would be to court disaster with the finished receiver.

Assembly

The assembly of the receiver is quite simple, it merely being necessary to mount the parts on the base-board and panel as shown in the photos. The wiring diagram and layout is to scale for the base-board, and the sockets, coils and resisto-couplers may be screwed down in accordance with the diagram.

The dials should be put on the SLF condensers so that they read zero against their indicating marks when the plates are entirely interleaved. This is just the opposite of the manner of attaching dials on SLW condensers. In assembling the set, the panel should not be screwed to the baseboard until all possible wiring has been put on each separately.

Wiring

The wiring of the set is the simplest of assembly operations. The soldering iron should be heated, the point filed bright, rubbed in paste, and then in solder so that it will acquire a coat of tin, without which it would be impossible to solder. Each lug to be soldered should have the point of a pin carrying a little paste rubbed on

PARTS REQUIRED

3 S-M 311.00035 S. L. F. Condensers.	1 7x24" Drilled, Sanded and Engraved Panel.
3 4" Naald Molded Dials.	1 7x23 Oak Base Board.
3 S-M 515 Coil Sockets.	1 Belden 5-Lead Color Cable.
2 S-M 112-A Inductances	15 Bus-Bar Lengths.
1 S-M 1110-A Inductance.	12 ¼-inch No. 6 R.H.N.P. brass wood screws.
6 S-M 510 Sockets.	10 ½-inch No. 6 R.H.N.P. brass wood screws.
1 Carter 6-ohm Imp. Rheostat.	6 ¼-inch No. 6 R.H.N.P. brass wood screws.
1 Central Laboratory 500,000-ohm Modulator.	1 Rosin Core Solder.
3 Daven Resisto-Couplers.	1 Spaggetti.
3 1/10 meg. Leaks.	27 Tinned Lugs.
1 ¼ meg. Daven Leak.	Tools required: Screw-driver, side-cutting pliers, soldering iron and non-corrosive soldering paste and hand drill with drills and countersinks.
1 ½ meg. Daven Leak.	
1 ½ meg. Daven Leak.	
1 Carter 101 Jack.	
1 Carter 102-A Jack.	
1 Benjamin On-off Switch.	
1 .002 M. F. Condenser.	
2 S-M .5 M. F. By-pass Condensers.	

then Musselman charted tubes, type 5VA with type 5VC in the last audio stage, will be found excellent. For dry cell operation, UX199 tubes with a UX120 in the last stage are OK. For maximum power using dry cells, Musselman 3VA tubes should be used, as they are more powerful than UX199s. Dry cell tubes will give about 10% less volume than storage battery types, but the sensitivity and selectivity of the set will be the same with either type.

Results Obtained During August

During the latter part of August, the receiver was tested in the center of the Chicago loop district, among steel buildings, and in comparison with

point had been reached where the additional sensitivity of the "Super" was useless. The other sets tested failed signally to equal the "Super" or r. f. set—even to the point of the number of stations heard. Frequently DX stations would operate a speaker on the super or r. f. set, yet could not be heard on the other factory-built sets. The results in selectivity were similar. Either the "Super" or r. f. set would eliminate some ten local broadcasters, a few less than 500 yards distant, which completely blanketed the other sets. Side-bands could be cut on any station at will with either "Super" or r. f. set, but not with the others. On local broadcasters within one mile, the "Super," shielded, was more selec-

the lug itself not the iron. Resin on a joint does not hurt it, providing there is solid solder underneath. Do not try to wire with anything but perfectly straight bus bar rolled flat between two boards. Then measure it carefully, cut and bend it to size, tin the ends, and finally solder it in place.

Many constructors prefer to use flexible wire in connecting up sets. In this particular receiver, this is permissible only for the filament battery, and audio amplifier sections. All r. f. amplifier wiring should be of stiff bus bar, as illustrated, in order not to interfere with the satisfactory operation of the simplified control feature.

Inductances

For the broadcast wave-length range, a 110A coil will be required in the left or antenna socket, and two 112A coils in the two right hand sockets. For the 90 to 210 meter band, one 110B and two 112B coils are needed, with one 110C and two 112C coils for the 50 to 110 meter wave-length band.

Testing

After the receiver has been completed, and the wiring checked against the circuit diagrams, it may be connected up, using one standard A battery as required, say a 6-volt, 90-ampere storage battery for UV201A's, one 4½-volt C battery and 135 volts of B battery consisting of large 22½ or 45 volt blocks. The ends of the color cord are terminated at the batteries, with the exception of the B45 and B90 leads. With those unconnected, a tube inserted in a socket should light, if

the switch is on, and the rheostat is turned on. If this happens, remove the A-plus lead from the A battery, and substitute for it the B135 and then the B90 leads.

The tube should not light—if it does, the circuit is incorrect and should be checked for errors. Assuming the tube not to light all batteries should be connected properly to the set. A Bakelite "B" eliminator will work out very nicely, and entirely eliminate troubles frequently due to poor "B" batteries.

With a water-pipe ground connected to either 1 or 2 of the left coil socket, and a 25- to 40-foot single wire indoor or outdoor antenna connected to whichever post (1 or 2) the ground has not been connected to, the set may be tuned, using the three dials. It should first be operated with headphones. The modulator or volume control should be turned all the way to the right, or at maximum. The antenna coil rotor should be so adjusted that its axis is parallel to that of the stator coils. All three dials will read practically alike—that is, they will all be set at within one or two degrees of each other for a given station. Since each dial division may be assumed to represent approximately 10 kc. with S.L.F. condensers, a station might be located approximately as follows:

Locating Stations

For simplicity, let us assume that zero on the dials equals 500 kc. and 100 degrees equals 1500 kc. Thus, we have 10 kc. per dial division. Suppose we want WHT. 750 kc. (400 meters).

(we get this information from the call book or daily paper). Then 500 kc., our lower limit, subtracted from 750 kc.—WHT's frequency—gives us 250 kc., which divided by 10 kc.—the frequency variation per dial degree—gives us 25. Thus, setting the dials at 25 degrees plus or minus one or two divisions will tune the set to 750 kc. (400 meters).

Suppose we were using straight line wave-length condensers. The process is different. Our wave-length range covered by 100 dial degrees may be assumed to be 200 to 550 meters, or a range of 350 meters. Thus, each dial division represents 3.5 meters. Suppose we want WHT again, at 400 meters. Then 200—our low wave-length limit—subtracted from 400—WHT's wave—gives 200, which, divided by 3.5—the number of meters per dial division—gives us approximately 57—the setting at which the set will be tuned to 400 meters.

It must be remembered that these figures are at best but approximate, due to unavoidable variation in individual receivers and tubes.

It is hardly necessary to say that the builder will be well repaid for this effort in building the set—he will be, since it is about impossible to build a practical receiver, equally simple, capable of delivering better results. A hundred stations will not be heard the first night of operation—the set is far too selective for that. It will require several nights of patient tuning before the builder will realize that he really has a better set than his friends.

Variable Resistance in Radio Circuits

(Continued from page 137)

of the variable resistance. Connect the other terminal of the variable resistance to the 90-volt binding post. The fixed condensers C1 and C2, which are .5 mfd. each, are connected as shown in the drawing, one each from the battery side of the primary to the negative filament of the tube.

The majority of manufacturers follow the practice of using two rheostats for a five-tube set, principally from the standpoint of either symmetry or economy, and this system, using one rheostat for the detector and one for both the radio and audio tubes, is detrimental to getting the best results out of any radio detector and audio combination and should be rectified. Another rheostat is not necessary; simply disconnect the audio frequency tubes from the rheostat that controls them and connect Amperites in the leads from the negative terminals of the sockets to the switch. It is surprising what a difference this will be

found to make in increased selectivity, in eliminating noises and in added sensitivity.

These two simple changes, a variable resistance in the plate circuits of the R.F. tubes and separate filament control for those same tubes, will make of any receiver now giving unsatisfactory, or not altogether satisfactory, results a thing of intense personal gratification to him who makes the changes when distant stations are pulled in smoothly and noiselessly.

The three-circuit tuner, which has been popularized under various commercial titles, has the instability common to regenerative circuits working at peak efficiency in that they oscillate whenever the circuit is disturbed.

It has been found that this deficiency can be overcome by controlling the feed-back with a Clarostat, which not only makes the circuit more stable, but also increases the volume because close coupling can be maintained be-

tween the tickler and secondary on all wave-lengths.

The function of the Clarostat across the tickler or plate coil is to strengthen or weaken the magnetic field produced by this coil without disturbing the constants of the rest of the circuit, which invariably accompanies a change in the position of a movable tickler coil. With the Clarostat, coupling between the secondary and tickler is always fixed and at maximum and therefore a signal of much greater volume can be obtained, together with a still more important advantage, one that appeals to everyone—a greater freedom from distortion in voice and music.

In the drawing L1, L2, and L3 are respectively the primary, secondary and tickler of the conventional three-circuit tuner. C1 is a .0005 mf. variable condenser, R is a 30-ohm rheostat, and R1 a 20-ohm rheostat. C2 is a .001 by-pass condenser.

Analyzing the "Diamond of the Air"

By JOHN F. RIDER, Member I.R.E.

MUCH is said and written about the various receivers that make their appearance before the constructively inclined radio fan and it must seem strange to the fan who is really interested in the art of radio that very few of these producers really supply any data to substantiate the claims made for the receivers. The reason for this is a matter of conjecture. Some no doubt do not care to publish this information, realizing that it would not be beneficial to their cause. Then again others do not care to go through all the trouble entailed. But be that as it may, those who do supply this information, and prove that their product does possess the merits claimed are compensated accordingly.

Now, would it not really be better for all concerned if some standard were developed whereby the prospective purchaser or constructor would be guided before making his investment in a receiver or a kit with which to construct a receiver? To assert that any one receiver will receive signals emanating from a station 2,000 or 3,000 miles distant is making a claim that will be very hard to fulfill. Would it not be more sagacious advertising to state that the receiver possesses certain amplifying powers, in the radio frequency side and in the audio frequency side? And with a set standard, a receiver with a certain value of amplification under normal conditions would be responsive to signals of a certain intensity, which values could again be interpreted into distance and power of the transmitter. With the values of amplification specified for each receiver it would be very easy for the non-technical man to decide upon the receiver he desired. And it is an admitted fact that with the receivers advertised as they are at present one well versed in the art must hedge before arriving at a decision.

The Diamond Under Test

With the above in mind and for the edification of the fan who may be interested, the writer conducted extensive experiments upon the 1926 Model Diamond of the Air to determine just what degree of amplification is being obtained in each of the stages; furthermore to ascertain the general degree of efficiency from the aerial binding posts through the various parts in the receiver to the loud speaker terminals. The findings will be described in the

following paragraphs. But before entering into the actual discussion it is necessary to consider for a short while some factors governing the design of radio receivers.

The complete constructional details of the "Diamond of the Air" appeared in the January issue of *Radio Review*.

In the first place the design of a good radio receiver is not what most fans imagine it to be. It is not the selecting of certain coils, condensers,

in the radio frequency tubes must be decided beforehand, since an overloaded detector tube is just as bad as some other defect in the design.

The Distortion Factor

The extent of regeneration in the radio frequency side, and its control, are of paramount importance, because they have a tremendous effect upon the distortion possible in the radio fre-

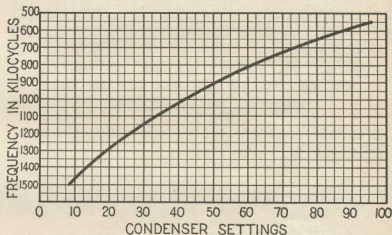

FIG. 1

The tuning curve of the Streamline straight line frequency condenser, used in conjunction with the Bruno R.F. coil in the 1926 Model Diamond. The slight drop in the lower part of the curve is due to the distributed capacity of the coil, since no coil can be made with zero distributed capacity. The curve shows how closely actual S.F. tuning is approximated.

sockets, rheostats, transformers and resistances, followed by certain wiring up of the parts until the receiver is completed, to be then vivisected and rejuvenated until the final product is produced. The cut and try method is an extremely expensive proposition, as many manufacturers have found to their disillusionment. To design a receiver one must know his requirements beforehand. The frequency spectrum or wave-length band to be covered, the most efficient inductance to capacity (L to C) ratio for that wave-length band and the type of coil used are factors of great importance, since they control the wave-length amplification curve, that is, the amount of amplification obtainable upon the various wave-lengths within the wave-length band. The design of the radio frequency amplifying side must be independent of the audio side. The amount of amplification to be obtained

frequency side. The same is true of the degree of selectivity. Excessive selectivity invariably results in distortion, hence that must be excluded. Proceeding deeper into the receiver the designer encounters another multitude of requirements in the detector and audio frequency amplifying circuits which must be conquered. The choice of transformer, resistance, or impedance coupling lies before him. Perhaps a combination would be best; but that is for him to decide. So we see that a job well done is a gratifying accomplishment.

Wave Range, 175 to 560 Meters

Turning back to the laboratory tests, the first determination is the wave-length range of the receiver. This result is independent of amplification, oscillation, distortion in any circuit, etc. The receiver must cover the present broadcast band, from 200 to 560

eters, and to accomplish this effectively, so as to permit satisfactory tuning on both ends of the scale it must reach below 200 meters and above 550 meters. A calibrated modulated radio frequency oscillator was used in the tests of the Diamond. The Precision

separate the station settings uniformly. The resultant curve, frequency against dial settings, is shown in Fig. 1. When making these determinations the tickler control setting is fixed at 0 as we are concerned solely with the action of the condensers as tuning

Furthermore, the physical construction of the circuit is of great importance. By this is meant the physical design of the inductance; its winding form, shape factor, the wire used, etc. It is therefore obvious that even a tuned circuit cannot afford maximum response over the entire band, but despite that inherent handicap, the designer of the receiver has it in his power to strive for the utmost amplification through the band. And the designer of a tuned radio frequency receiver will strive to effect a straight line for the wave-length vs. amplification curve, for by so doing he attains the much-desired objective—uniform efficiency over the entire band. To some this may seem a simple task; a few experiments will prove the reverse.

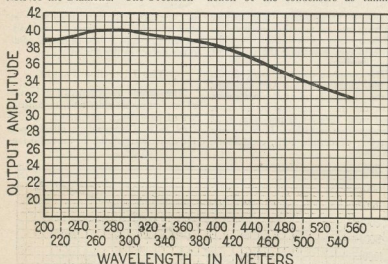

FIG. 2

The amplification of the unaided R.F. circuit in the Diamond is highest at 280 meters, as this curve shows. The curve was made in a test in which no regeneration was employed, except that inherent in the tube. The result with the tickler playing its important part will be disclosed in a later issue. The above curve compares favorably with that of other tuned R.F. receivers. At the higher capacity settings (higher waves) there is a decided drop in every tuned R.F. circuit.

Wave-meter with a wave-length band of from 75 to 24,000 meters was beside the oscillator. In substance the oscillator is a miniature broadcasting station. The energy from the oscillator is picked up by the coupling coil, acting as a portion of the phantom antenna (condenser and the resistance box) whose constants approximate an average receiving aerial. Passing through the "dummy" aerial the energy is fed into the receiver, amplified, detected and then amplified again and passed into a measuring circuit made up of a calibrated crystal detector and a special microammeter (200 microamps full scale). By means of a switch the output side of the receiver can be linked to either the measuring circuit or the loud speaker.

The wave-length range was found to be excellent, being from 175 to 560 meters, affording a wave-length ratio of 3.2.

The next move is to ascertain how close the variable condensers come to straight line frequency tuning. Being of this design, frequency settings of even steps should be distributed uniformly over the dial periphery. If this is the case station settings will be spread evenly over the dial, that is, with uniform separation between stations. This should not be construed as meaning that a straight line frequency condenser will eliminate any interfering stations. All it does is to

media, the operating characteristics of the tickler being considered in a separate paragraph, which will follow later in this text.

The Amplification Curve

The next item is the amplification vs. wave-length in the radio frequency system. The results obtained in this test are really of the greatest importance, since they indicate the actual efficiency of the design of the receiver. By this token we can observe the points of efficiency or deficiency. Fans may not be aware of it, but tuned radio frequency amplifiers, too, have points of greatest efficiency, that is, greatest amplification, although it is possible to tune each circuit to resonance with the incoming wave. The shortcomings of the old and now obsolete untuned transformer coupled radio frequency amplifiers were easily comprehended, insofar as amplification vs. wave-length was concerned, since every transformer has a peak, usually located on the mean wave-length of the band covered by the unit. And it was assumed that the inception of the tuned circuits would completely eliminate this fault. That, however, is impossible, as the operating characteristics of a tuned circuit are dependent to a large extent upon the applied frequency; therefore when the circuit is tuned to various wave-lengths the degree of response is altered each time.

Results Without Regeneration

The curve showing the amplification of the radio frequency signal on the various wave-lengths within the operating band of the Diamond of the Air is illustrated in Fig. 2. This curve was plotted without regeneration other than that due to the capacity within the tube. It shows clearly the degree of efficiency obtained on the various wave-lengths in the radio frequency circuits. When viewing this graph one must bear in mind that all artificial regeneration has been omitted. The effects of the regeneration control, as was mentioned previously, will be considered in detail subsequently.

As to the interpretation of the curve, it is apparent that the amplification "alls off" as the wave-length is increased beyond a certain point. This cannot be avoided and is an inherent defect in absolutely every tuned radio frequency receiver utilizing fixed primary circuits, and is attributable to the natural phenomena encountered in radio transmission. This peculiar action is the greater penetrating and carrying power of the signals on the lower bands. In addition, the number of turns in the primary circuit cause a greater reaction within the tube on the shorter wave-lengths, resulting in greater amplification. Furthermore, the greater inductive effect upon the lower wave band causes a greater voltage to be built up in the inductance and applied to the grid. And last, but not the least, the greater capacity used to tune the circuit to resonance on the higher wave-lengths also results in a slightly decreased grid voltage. Considering all the factors it is impossible to obtain as high a degree of amplification on the higher wave-length as is obtained on the lower band. So we observe that when the amplification on the higher wave-lengths is only slightly below that on the lower wave band the work of designing the circuits has been very effectively carried out.

Control Is Perfect

In the following we shall consider two items of paramount importance, in fact, the two most significant details in the 1926 Model Diamond of the Air. These are the voltage amplification factor of the stage of radio frequency amplification and of the regenerative detector. If these values are high and the associated circuits possess low values of effective resistance a high degree of amplification will be obtained in each tuning unit carrying radio frequency currents, resulting in good sensitivity and volume.

What the Amplification Factor Is

No doubt many fans are wondering about the voltage amplification factor of the tuned radio frequency stage and also of the detector. Just what is this voltage amplification factor? In

An Analysis of TRF

Tuned radio frequency amplification has during the past two years received so much exploitation and publicity that it is without a doubt the most widely known topic of the entire radio art among the vast host of radio fans. And correspondingly the majority of the fans, if not all, are thoroughly familiar with its function, it being to amplify the radio frequency currents before they reach the detector tube and are rectified and passed into the audio amplifiers. Now, as the stage of tuned radio frequency is intended as an amplifier of radio frequency currents, thereby augmenting the degree of sensitivity of the receiver, it is best to obtain the highest power of amplification, thereby obtaining the maximum efficiency. In technical

that there is a gain in signal intensity with each gain in the amplifying factor.

Varies for Number of Stages

The number of stages of tuned radio frequency amplification also governs the voltage amplification ratio factor of each stage. That is, each stage is designed to afford a certain value. This is unfortunate, but nevertheless true, it being necessary to reduce the amplifying power of each additional stage of radio frequency, or to use a uniform but decreased value throughout, when more than one stage are utilized. Hence the amplifying power of a well-designed single stage of radio frequency in a receiver employing only one, is invariably greater than that of any single stage in a multi-

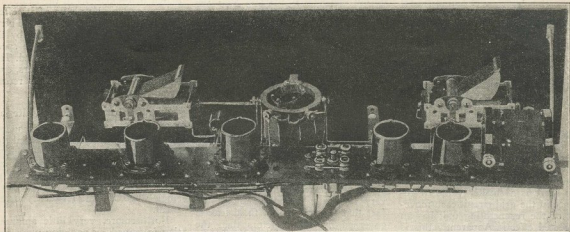

The rear view of the Diamond. Note the binding posts at right of the socket strip center. To the left two nuts and screws protrude. These are terminals of the audio-transformer. This method of mounting the transformer makes it fit snugly and serve as a support for the socket shelf.

simple language it is the amplifying power of the tube and coil combination. If a transformer is used in conjunction with the tube, it is the amplifying power of the tube and transformer combination. In other words it is the ratio between the voltage applied to the grid of the tube under test, and that applied to the grid of the subsequent tube. In a regenerative detector it is the increase in amplification, due to the regenerative effect, and is determined by measurement of the output of the detector tube alone, no other tube entering into this consideration, unless it be that of a vacuum tube voltmeter, utilized as the output indicating device.

Now, as the stage of tuned radio frequency amplification is for all measurement purposes entirely remote from the regenerative detector, each will be considered separately. Accordingly we will forget for a short while the regenerative detector and delve into the facts pertaining to the stage of tuned radio frequency amplification.

In language this would be the highest voltage amplification factor. Unfortunately, however, there are decided limits to this value, due to the amplifying characteristics of the tube itself, the tendency towards over-oscillation, which action would render the receiver unstable in operation, and the design of the various circuits comprising the tuned radio frequency stage.

This design factor includes the primaries, secondaries and inductances values of the two and also the capacity value between the two sets of inductances. Therefore when designing the radio frequency circuits to have a certain amplification factor it is necessary to strike a value consistent with the desired stability of operation and the general design of the receiver, that is, whether or not neutralization is to be employed, an independent oscillation control included, etc. These precautions are necessary because of the increased tendency toward over-oscillation as the voltage amplification factor is increased, although it is true

stage radio frequency amplifying unit. And the design of the Diamond of the Air has been well carried out, since the stage of tuned radio frequency amplification has an average voltage amplification factor of slightly more than 6 on wave-lengths within the broadcast band, from 200 to 560 meters. To some this value may appear small, in that the amplification constant of the tube is greater than that figure, but 6 is a very satisfactory value of voltage amplification for a stage of radio frequency, bearing in mind that the stage is perfectly stable.

The Regenerative Effect

Delving deeper we arrive at the other important item, the amplifying power of the regenerative detector. It is unnecessary to discuss the advantages accruing through the use of regeneration in every receiver, in so far as increased distance and receptivity are concerned, but the design of a unit that will provide a high value of amplification with perfect control warrants careful consideration. In the

first place, the attainment of regeneration is by no means difficult, but so that it be satisfactory it must be under perfect control from the minimum to the maximum wave-length covered by the tuning circuit. Furthermore, it must be a stable control with low loss circuits in the primary and secondary. This last mentioned factor has been neglected by many, but it is of importance, and many will be surprised to hear that regeneration control with a tickler or plate variometer is more difficult with a low loss secondary circuit than with a high loss system. This

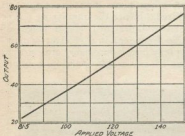

Curve showing the output as measured on the basis of various applied voltages (85 to 150) on the 100,000-ohm plate resistors in the Diamond. This curve holds good wherever such voltages and resistors are used. The 20-to-80 scale represents arbitrary figures that show accurately the proportional increase.

should not be construed to mean that it is more difficult to obtain, but more difficult to control. This is so because there is less positive resistance to be removed from the grid circuit. And when there is a smaller value of resistance in the grid circuit each movement of the regenerating unit has an augmented effect. Apparently this is a defect, but such is not the case, because a reduction in the necessity of regenerating minimizes distortion caused by excessive regeneration and there is no loss in volume, because the low-loss secondary permits a greater inductive voltage to be built up in the secondary winding and applied to the grid of the detector tube. In the Diamond of the Air the regeneration control is perfect from 0 to 100 on the control dial. Tests to determine the regenerative amplification showed an increase in output with regeneration to be 49 times that without regeneration, affording a voltage amplification ratio of 7. Again a very satisfactory value of amplification.

25% Above Two TRF Stages

Now we have two radio frequency amplifying circuits, one with an amplifying factor of 6 and the other of 7. If we assume for one moment a non-regenerative detector, it will possess a factor of unity (one) and with the single stage of radio frequency the combination will be 6 and 1. However, by virtue of the 7 for the regenerative detector, this is of greater amplifying power than the stage of radio

frequency amplification, and in reality we have the equal of two stages of tuned radio frequency amplification and non-regenerative detector, since the average tuned radio frequency receiver utilizing two stages of tuned radio frequency amplification has non-regenerative rectification. And in the Diamond of the Air the regenerative detector is more than equivalent to an extra stage of tuned radio frequency amplification and non-regenerative detector, in amplifying powers, not in the filtering effect. This must not be overlooked. The regenerative action of the detector, while increasing the degree of selectivity to a small extent, cannot increase that factor to equal the filtering effect of another stage of tuned radio frequency amplification. The increased amplification gained by the high voltage amplification factor of the regenerative detector over the non-regenerative detector and two stages of tuned radio frequency amplification approximated fully 25 to 30%, when measured against several popular 5-tube conventional type tuned radio frequency receivers.

Action of the Bretwood Leak

Another item of interest is the variable grid leak, and it is unfortunate in every respect that radio fans do not realize the importance of variable grid leaks in this day of many and various powered stations. Many discussions have been provoked by the grid leak, and many articles written about it, but very few have made mention of the fact that the value of a fixed leak is governed by other factors than the recommendation of one person. In substance, the value of the leak with a fixed condenser is dependent upon the intensity of the impressed signal, the kind of signal and last but not least the tube used. Now, if these three factors are encountered in every receiver at all times, it is quite apparent that the choice of a value of fixed leak recommended by one person is not always the correct one. The same value of leak will not permit the leakage from the grid of charges of various intensities, nor will it permit the complete discharge of the grid condenser within the required time. Hence the necessity of a variable leak. The advantages of a variable grid leak need not be described to one who has had occasion to use it at some certain time, but the fan who has never used a variable leak should by all means incorporate such a unit in his receiver.

Advice on "B" Battery Voltage

Many experimenters are prone to overlook entirely the importance of the plate voltage applied to the various tubes in a receiver, considering it as a necessary accessory, without any real

significance. But the plate voltage is a paramount item when the maximum efficiency and output are desired. Without the proper values of plate voltage, the trouble taken in the design of a receiver has gone for naught, and satisfactory results cannot be expected.

Take for instance the 1926 Model Diamond of the Air. One tube is utilized as a radio frequency amplifier, one as a detector and three as audio frequency amplifiers. This makes five tubes in all. Two plate leads are furnished. One supplies both the radio frequency tube and the detector and one the three audio tubes. Now, the design of the radio frequency stage took into consideration the value of plate potential that was to be normally applied to that tube, since the plate voltage is a controlling factor in the extent of oscillations in the radio frequency system, by virtue of its effect upon the tube characteristics. Therefore if operation, as intended by the designer, is to be achieved the specified plate voltage should be used. This of course applies to all receivers, even though no definite value was recommended for a set.

The Conjunctive Plate Voltage

In the Diamond the radio frequency tube is supplied with the potential that is applied to the plate of the detector tube, which practice is entirely satisfactory in a receiver of this type, since the tendency towards oscillation in a single stage of radio frequency is very small.

Furthermore, very little amplification is gained by applying more than 67½ or 75 volts to the plate of the radio frequency amplifying tube, since the input grid voltage fluctuations as compared with the audio tubes are very small, and it is really unnecessary to lengthen or straighten the characteristic curve beyond that obtained with 67½ volts on the plate. And since the design of the detector circuit is such as to permit the application of a plate potential of 67½ volts, without causing the detector tube to be critical in operation, it is a very feasible plan to supply both the radio frequency and detector tube plates from one source. With 75 volts upon the plates, the plate current drain of these two tubes is 11 milliamperes, divided equally between the two, each tube drawing 5.5 mls. The tubes used during tests were R. C. A., Cunningham and Muselman Certified, and the values quoted are averaged.

As to the operation of the detector tube, one can say very little, unless the particular tube used is at hand. The functioning of a tube as a detector is a peculiar action. Not that the rectifying action is different in the various tubes, but rather that the de-

gree of sensitivity is a very uncertain item. Some fans, due to the use of resistance coupling in some of the audio stages, may forget that the detector is coupled to the first stage of audio by means of a transformer, and accordingly apply an excessive plate voltage, in order that the effective voltage be sufficient. This high voltage will cause very poor rectification, because of the complete saturation of the tube, and in addition the regeneration control will not be very stable on the lower wave band. The fan should therefore observe that the coupling medium between the detector tube and the first stage of audio frequency is a transformer.

The Audio Plate Voltages

The selection of the plate voltage for the audio amplifying tubes is slightly more complicated, in that it should be higher than is normally used for audio amplification. This is brought about by the different coupling media used. It was customary with transformer coupled audio amplifying systems to use 90 volts as standard. But the growth in popularity of resistance coupling necessitated a change in this value, that is, an increase. This is necessary so that the proper effective voltage be applied to the tube plate, since the additional resistance of the coupling resistor causes a very large voltage drop. In the average audio frequency amplifying system, using transformers, the resistance of the complete plate circuit is the sum of the tube impedance and the resistance of the transformer primary. In actual figures this approximates 14,000 to

QUARTZITE COILS

will improve the efficiency of any receiver. Replace your old coils with a set of these famous low loss coils and wonder at the difference.



This pair of matched coils are used and endorsed by Herman Bernard in the 1926 Diamond of the Air.



Bruno "99" 3-circuit tuner. Wound on quartzite glass tuning with .0005 condenser and has wave length range of 175-575 meters. Price..... **\$5.50**

Bruno "55" Radio frequency transformer. Matched with "99" tuner to have similar dial reading. Tunes from 175-575 meters. Price..... **\$3.00**

Bruno Radio Corporation, N.Y.C., N.Y.

Sales Offices:

Philadelphia
611 Widener Bldg.

Detroit
159 E. Elizabeth Av.

Chicago
337 W. Madison St.

San Francisco
274 Brannan St.

16,000 ohms (DC). But in resistance coupled system the transformer primary is replaced by the coupling resistor, and in place of 1,500-ohm primary resistance we have a 100,000 to 120,000-ohm resistance unit, hence the

total resistance is many times that previously resulting. Now, if the same plate potential is separately applied across both values of resistance it is obvious that the drop across the higher
(Continued on page 173)

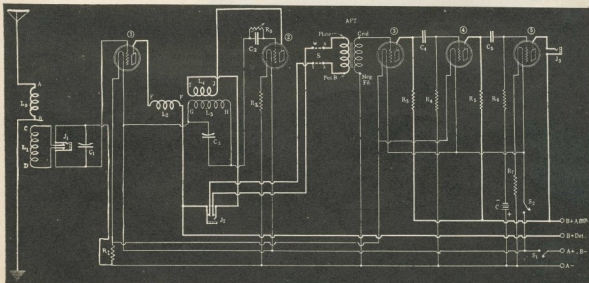

The plate resistors, shown in the above diagram of the 1926 Model Diamond of the Air, are R3 and R5, each 100,000 ohms. The curve on the opposite page shows that a B battery voltage of 140 gives about 1.75 as great an output as a voltage of 105 (the proportion of 70 to 40).

Loud Speaker Uses Newly Discovered Principle

WITH the possible exception of the development of the cone type loud speaker, this particular branch of the radio field has been singularly devoid of any real advances in the past few years. The reproduction of the majority of speakers is faithful over only a portion of the frequency band used in music. The cone speakers, when properly made, have a deep, resonant tone and bring out the lower register with unusual clarity. However, while they represent a distinct improvement in this respect they undoubtedly require some further development. It remained for a Russian

scientist, Dr. Herman Fisher, to introduce a radical improvement in this direction.

About a year ago Dr. Fisher startled the Paris Conservatory of Music and the entire musical world by producing violins which not only rivaled the famous Stradivarius instruments, but according to an unprejudiced, comparative test vote, actually exceeded the quality of what have always been regarded the ultimate in violins. Dr. Fisher solved the age old secret of the old violin craftsmen—a secret which has baffled acoustic experts and musical instrument experts for years.

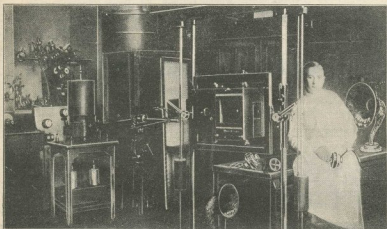

Dr. Herman Fisher in his laboratory where he developed his unique loud speaker.

The discovery brought to light the fact that instead of being in the geometric center of the violin back, the greatest thickness of wood in the Stradivarius is actually under the foot of the sounding post rests.

Upon his arrival in America, Dr. Fisher was at once impressed with the need of improvement in the reproducing units for radio, and accurately located the source of the greatest difficulty. He realized that true reproduction of tone qualities could not be obtained without careful regard for the diaphragm. It was therefore quite an interesting source of experiment for the discoverer of the violin secret. During the summer of 1925, the discoveries of the scientist, Dr. Fisher, were brought to the attention of Mr. F. S. Tower, president of the Tower Mfg. Corp., makers of loud speakers and head sets. Realizing the importance of the developments, Mr. Tower

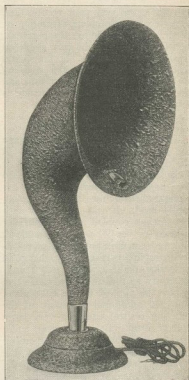

Fibre horn speaker equipped with new-type unit.

immediately arranged with Dr. Fisher for the application of the principle to the improvement of loud speaker units.

After several months of careful research along these lines, Dr. Fisher perfected a new type of diaphragm, utilizing the same essential principle of varying thickness that made the old violins produce such marvellously pure notes. The new diaphragm is a composite, made by welding together two separate diaphragms of different materials, the resulting diaphragm having varying thicknesses. The diaphragm is thus quicker at one portion of its surface, much as is the case with the violins referred to. It is claimed that this proper placing of the thickest part of the diaphragm results in a diaphragm capable of producing, in conjunction with the proper loud speaker, a remarkably faithful reproduction of all tones.

One portion of the diaphragm is metal—to bring out high notes. The
(Continued on page 168)

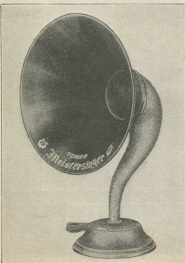

A speaker which utilizes Dr. Fisher's recent development.

The Hammerlund-Roberts Set

An Improved Five Tube Receiver

By HARRY J. MARX

THE judgment of radio fans is final in deciding the efficiency of a circuit. What better proof of the value of a circuit than the continued popularity. What better proof of the value of a circuit than the continued popularity, extended to the Robert's Knockout receiver? Still, every circuit is in a state of continuous evolution. The greater the popularity the more there will be experimenting with it. This has been the case with the Roberts which has now been crystallized in its final form as the Hammerlund-Roberts circuit.

The circuit as it is shown in its final form, Fig. 1, is the result of painstaking experimental work and final judgment of ten of our foremost engineers. It has been designed and balanced and in addition so simplified that the layman or radio fan need only to follow the simple details of instruction in order to build a set that will absolutely duplicate the original just like a manufactured set.

The Circuit

Here is a circuit employing tuned, neutralized radio frequency amplification of unusual efficiency, a regenerative detector, then a stage of normal audio frequency amplification, followed by a new form of power amplifier that employs a Lyric audio transformer but requires two tubes in parallel connection. This last arrangement is the best method in which the volume that is delivered from the second stage can be utilized with absolute clarity of reception and the high degree of tone quality which is so desired by the more critical fan.

It is apparent that the circuit embodies and incorporates every important and worth-while refinement of control and accuracy of design that is known. But all this careful attention of design is based on the importance of using the apparatus as specified and around which the entire receiver is designed.

The reflex feature of the old Roberts Circuit has been eliminated because of the difficulties that every fan has encountered in the construc-

tion of reflex sets. This elimination has also been instrumental in the unusual improvement in selectivity of the set.

Although a home-constructed receiver, it resembles the best of manufactured sets in appearance and surpasses them in performance. A sloping panel, regularly engraved and with gold finish marking will make the

reostat for the radio frequency tube, put tube and, therefore, avoids the distortion due to overloaded detector and audio tubes.

There are two major controls—the condenser tuning dials, and two minor—the tickler for selectivity and the rheostat for volume. What could be simpler and more desirable for the home where all members of the fam-

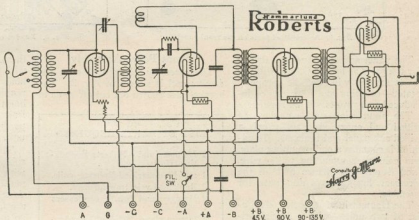

Fig. 1. Schematic wiring diagram of the Hammerlund-Roberts receiver.

most skeptical fan prone to boast of his set.

Circuit Operation

The coils are of exceptionally low loss type, designed especially for this circuit. This provides for tuning over the entire broadcast wave-length range and with that degree of selectivity necessary in order to eliminate powerful interference from local stations in order to bring in the long distance ones.

Straight line frequency condensers provide for proper separation of stations on a basis of uniform spacing of dial graduations. Because of the elimination of the reflex features the first tuning circuit is much more effective in separating the stations than before. The efficiency of the detector circuit tuning is obvious when we stop to consider the regenerative feature. The little tickler control is the guardian of selectivity and at the same time it builds the volume to all that is to be desired on long distance stations.

Volume is controlled by means of a

This controls volume right at the in-ly wants to know how the set works so as to use it themselves?

Comment on Apparatus

In the usual set construction article—the fan must lay out his panel, drill and countersink the holes, rarely has he the opportunity of owning an engraved panel. In this case the drilled and engraved panel, with a drilled sub-panel and even brackets for mounting can be purchased as a unit. The products are all nationally known, so there is no difficulty in obtaining them anywhere. The complete parts for building the set but without a cabinet will run a few cents over sixty dollars.

Considering the individual variations in set construction as described in various publications, and the difficulties encountered by the fans in altering layouts and circuits to suit their fancies, it is not hard to appreciate the attractions of a plan which minimizes the dimensioning, layout and assembly of a set.

The List of Parts and Assembly

The important item in a receiver is not only the circuit, but the selection of apparatus used. Contrary to what many think, you cannot substitute anything on hand or that can be bought cheap. A nationally recognized product is one that has earned its reputation. Many a circuit has been condemned simply because substitutes failed to produce.

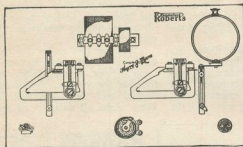

Fig. 2. Assembly of parts on the front panel.

The panel and sub-panel are drilled for the parts as listed. Others will not fit—terminals will not be properly located—coupling and interference introduced and results will be lacking.

The foundation unit contains the drilled and engraved front panel, a drilled sub-panel and brackets. In addition it contains a coil mounting plate, grid condenser mounting posts, wire, fixed 4 ohms resistance and all the necessary lugs, screws and nuts for assembly.

The Hammarlund-Roberts coils consist of two units—with a special primary winding, a standard secondary and a variable coupling tickler coil. These units must be efficient low loss apparatus in order to perform their functions properly.

The variable condensers must be of similar quality so as to eliminate losses and keep the selectivity which is characteristic of the set. The audio transformers were selected because of their ability to step-up the voltage passed through them without distortion. They are important factors when clear and beautiful reception is desired. The amperites control the filaments of four tubes and eliminate rheostats with the exception of the Carter Imp which is used as a volume control. The capacity of the neutralizing condenser is important as has been predetermined by the design of the neutralizing system. All the mounting holes, and holes for the wires through the sub-panel are drilled in exactly the proper place for mounting Na-Ald sockets. The grid and also the fixed condensers must be accurate and high quality, for this reason Dubilier has been specified. The mounting holes for the grid condenser have been drilled in the sub-panel for this type. The Union phone tip jacks mounted along the edge of

the sub-panel facilitate battery connections and make a neat looking job.

No value is given for the grid leak as it differs for various tubes—but as it is important that the resistance remains fixed and not susceptible to atmospheric changes, ink impregnated paper strip types cannot be used. The Durham is a metallized filament leak which remains fixed regardless of changes in temperature.

Front Panel Assembly

The assembly of apparatus on the front panel is shown in Fig. 2. The brackets are shown but cut off so as to

LIST OF PARTS REQUIRED

- 1 Hammarlund - Roberts Foundation Unit.
- 1 set Hammarlund-Roberts coils.
- 2 Rauland-Lyric transformers.
- 2 Hammarlund S.L.F. condensers .0005 mfd.
- 1 Hammarlund "Midget" condenser 16 mfd.
- 5 Na-Ald "De-Luxe" sockets.
- 1 Na-Ald 1 1/4-inch dial K-3844.
- 2 Na-Ald "Super De-Luxe" 4-inch dials.
- 1 Carter 25-ohm "Imp" rheostat.
- 1 Carter single-circuit jack No. 101.
- 1 Carter "Imp" battery switch.
- 1 Durham metallized resistor (grid leak).
- 4 Radiall Amperites No. 1-A.
- 1 Dubilier grid condenser .00025 mfd.—Type 640G.
- 1 Dubilier fixed condenser .002 mfd.—Type 640.
- 1 Dubilier fixed condenser .006 mfd.—Type 640.
- 10 Union phone tip jacks.

avoid any confusion. The shield plates of the condensers are against the panel. The one on the left in the illustration goes behind the bracket. It is best to mount the condensers and shield plates before fastening the brackets to the panel.

The coil with tickler should be mounted in the position illustrated. It is important that units be fastened with terminals located as shown. The

antenna coil mounts on a brass plate, which is fastened with two screws into tapped holes in the right-hand bracket.

Sub-Panel Assembly

In the sub-panel assembly, there are two sides to be considered. Fig. 3, the top or upper half of illustration, should be assembled first.

The four sockets on the left have their terminals facing the same but the one on the right is reversed from

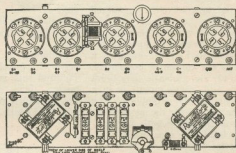

Fig. 3. Layout of parts on sub-panel.

these. The center socket is fastened with two screws that go into tapped holes in the sub-panel, but the others require screws and nuts as clearance holes are drilled for these. The grid leak is mounted on two brass supports, furnished with the foundation unit.

The lower half of Fig. 3 shows the sub-panel mounted on the brackets with the transformers in place. The ten Union phone tip jacks should be fastened as shown. The amperites are fastened by means of screws which go into tapped holes in the sub-panel. The four ohm fixed resistance and the .006 by-pass condenser are shown in place but are not fastened, the wiring holds them in place.

Wiring and Operation

It must be kept in mind that the tubes in this receiver are not laid out as in the conventional set. That is, the radio frequency tube first, the detector next and then the audio frequency tubes. For simplicity and short leads in wiring, the first audio tube was placed on the extreme right, Fig. 4. The second from the right is the radio frequency amplifier, the one in the center the detector and the two on the left are the parallel connected tubes of the second audio stage.

Wiring

In wiring this set these points are important—all leads are to be kept short as possible and all points should be well soldered. This doesn't mean slapper solder all over everything. Make it hold—use a hot iron. The filament wiring goes in first. In the picture wiring diagram a loop, where wires cross, indicates no connection—while a black dot means they are connected and soldered.

Alongside some of the socket terminals are shown holes through which the wires are intended to pass in order to connect to units on the lower side. These holes are also shown in the view of the lower side. The wires are shown disappearing into these holes in the upper view and should be followed up from the respective holes in the lower view. Where wiring disappears under some unit such as a transformer it is shown in dotted lines in order to complete the connection.

Most of the filament wiring can be completed before the sub-panel is mounted on the brackets and the transformers put in place.

In the lower right corner there is a note "This wire is connected to the screw and bracket." Before the transformer is mounted, a terminal plug is passed over the screw on the rear edge fastening the sub-panel to the right bracket. The lead from the B-, A- and C+, and the ground phone tip jacks, is connected to this terminal. This puts the bracket in the negative filament circuit. Where this bracket is fastened to the front panel a terminal lug is shown under the nut on the lower screw of the bracket. This lug is wired to the battery switch which closes this negative circuit to the switch.

The Antenna Coil

This negative filament and ground lead must be connected to the first lug near the front panel on the upper terminal strip of the antenna coil. This is done by fastening a lug under one of the screws that hold the mounting plate on the aluminum bracket.

The antenna coil unit has six terminals, two lower ones for the secondary circuit and four on the upper strip—the one of which is grounded as explained. The other three are antenna terminals and are placed there so the fan can try all of them with the set in operation, to find which gives the best results. The antenna lead can be flexible with a clip on the end so the connection can be altered as desired. This is the reason for the note "see instructions."

Operation

Turn the volume control on full and advance the sensitivity dial to its maximum position. Now, by simultaneously rotating the two tuning dials at approximately the same settings, a squeal should be heard in the loud speaker, provided any stations are "on the air." Adjust the dials for maximum squeal and then reduce the setting of the sensitivity dial. This will eliminate the squeal and result in re-

ception of music or whatever is being broadcast at the time.

Perhaps on local stations the advancement of the volume control to its limit will produce distorted reception because of tubes overloading. If this is the case it is only necessary to reduce on the setting of the volume con-

Neutralization

Tune in some moderately strong station, and, listening in with headphones or loud speaker, turn out the radio frequency tube by means of the volume rheostat. Adjust the midjet condenser setting until signals either

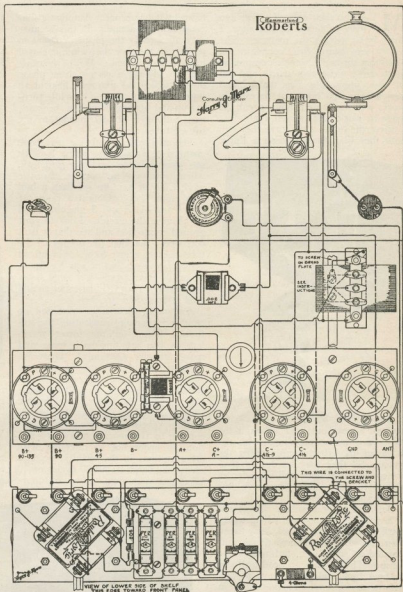

Fig. 4. Complete wiring diagram and layout of the Hammarland-Roberts set.

trol, or else reduce the amount of "B" battery voltage applied to the last audio amplifier tubes.

Regeneration should be obtained smoothly by advancing the sensitivity control, that is the tube should go in and out of oscillation quite evenly and slowly. If this is not the case reduce on the detector B voltage applied to the B positive 45 jack.

disappear entirely or at a decided minimum. It will be necessary to retune slightly after this and then the tube should again be turned out and the condenser readjusted slightly to a more exact position. There is a distinct minimum of sound when the neutralizing condenser has been correctly set.

Your Set May Be Down, But It's Never Out

By ARNOLD E. PFEIFFER

MY set worked so well a year ago when I bought it, but now, I don't know what's the matter." The writer has heard this complaint so often that through sheer desperation he needs must write this article and tell the radio public why a set that worked well a year ago need not necessarily work well now, and how it can be made to work just as well again.

First, the tubes. Of course they still light, but that doesn't mean a thing.

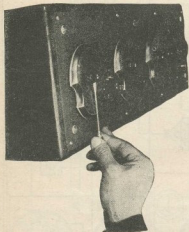

The dials can easily be attached to your present set with the aid of a screwdriver.

Tubes seldom burn out now-a-days, they just wear out, and although the tubes in your set may light with the brilliancy of Liberty enlightening the world, still they may be deadlier than the conventional door nail in-so-far as ability to relay high frequency impulses are concerned.

So, look to your tubes. Try them in a friend's set that's working up to snuff, and if they are dead, bury them. You can, of course, have them rejuvenated at small cost, but what's the sense? They'll only go dead again in a short time and you'll have to buy new ones anyway. If the tubes in your set have gone the way of all earthy things, buy a complete new set. Buy them from a dealer who will test each one before he gives it to you—who will test them on the meters. In this way only can you be sure you are getting good tubes.

In the new sets coming on the market arrangements are made to prolong the life of tubes by employing self adjusting rheostats for controlling the

filament temperature. Automatic filament controls actually do this because they allow only the proper current to pass from the time the switch is closed until it is opened. With rheostats there is always a certain time phase during which the filaments heat at an improper temperature, i.e., while turning up and turning down the rheostats, and nothing is so detrimental to the life of tubes as this.

The grid leak in your set may have changed its value since you've had the set—grid leaks do—and the grid leak, when its value is not correct, can raise more Cain in a radio set than a bull in a china shop. Obtain a range of grid leaks—1, 2 and 3 megohms and try them in the circuit. Look to your ground connection and see that it isn't corroded. See that the prongs of the tube sockets aren't loose. Go up on the roof and see that no one has hooked on to your aerial—it's being done, you know. Your "B" batteries should read at least 34 volts each.

And now, selectivity. You had no trouble a year ago separating the stations. Now, on the lower wave-lengths you are finding it more and more difficult. Certainly! There are twice as many stations to separate now as there were a year ago, and it is becoming increasingly difficult to separate them at the lower wave-lengths. This is caused by the fact that broadcasting wave-lengths are assigned according to frequencies, and every station, in order not to interfere with other stations in the vicinity, needs a frequency band of 10,000 cycles or 10 kilocycles of its own. Now, in tuning

frequency to which a tuned circuit responds, while a considerable change in condenser capacity is needed for the same frequency variation at the higher dial settings.

Hence, with the condensers in your set, the readings of the dial will not correspond to the variation in frequency, which means that at the lower settings of the dial, stations are crowded together, while at higher readings of the dial the stations are scattered. This problem will become more acute when space will have to be allotted to more stations, because this space can be allotted only by assigning to these stations wave-lengths below 200

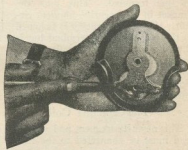

The mechanism is all enclosed within the dial.

meters, which means among the lower numbers on the dial.

As a result of this confused condition of the dial the stations are scattered. This problem will become more acute when space will have to be allotted to more stations, because this space can be allotted only by assigning to these stations wave-lengths below 200

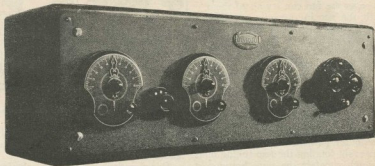

A typical radio receiving set fitted with Tune-Rite vernier dials.

at the lower dial settings a small change in condenser capacity will cause a great variation in the fre-

quency condenser is the so-called straight-line frequency condenser, which when well
(Continued on page 155)

The Gen-Win Lemnis Coil Receiver

By EDWARD SPIEGLER

THE statement to the effect that the success of most radio frequency receivers depends on the particular coils used in them can be made with a comfortable degree of safety. Any radio fan who has tried straight tuned R.F. circuits with different types of transformers will willingly verify it, for he knows that efficient coils, possessing confined magnetic fields that remain in the coils and that do not cause troublesome feed-back between R.F. tubes, are what make the difference between a stable, selective receiver, and a squealingly troublesome and broadly tuning one.

It was with these facts in mind that the Gen-Win "Lemnis-Coils," a new type of radio frequency transformer,

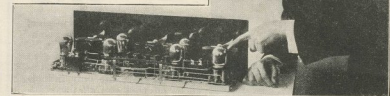

The author is shown here pointing to the Daven Mu-6 power tube in the last stage.

vent from straying by the peculiar design of the winding that produces them, so there is no direct coupling between the stages of a radio frequency receiver using the inductances. The coils use an elongated reverse curve of extraordinary length, which gives them the desirable characteristics of the solenoid with none of the latter's

ed by the radio fan with little difficulty. The coils can, in fact, be connected in any standard radio frequency circuit and will work in an extremely satisfactory manner, but a definite set is described here so that the constructor will have something definite to work on. The outfit has actually been made as the photographs show, so no one need fear he is going to try something that has never graduated from the drawing board stage.

This Lemnis-Coil set involves two stages of tuned radio frequency amplification, detector, and three stages of resistance coupled audio amplification, which means six tubes in all. It is highly selective and sensitive, and because of the resistance amplifiers, boasts of absolutely perfect tone quality. The parts required are all standard, and can be purchased without



The front of panel is well balanced as can be seen above. The latest vernier type dials are used to obtain careful tuning adjustment.

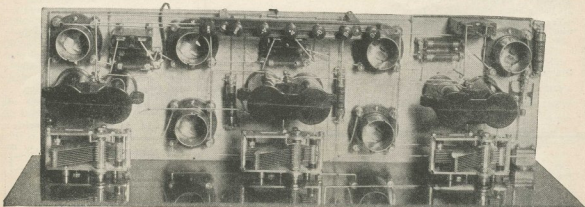

The top view of the receiver showing how the parts are arranged.

were designed by the engineers of the General Winding Company, Inc., the well-known coil manufacturers. The new transformers, wound according to the "lemniscate" principle, incorporate many features, foremost among which is its confined magnetic field. The magnetic lines of force are pre-

inherent bad features. The coils, by the way, are decidedly not of the "binocular" type; the latter employs two separate windings, whereas the Lemnis-Coils use only one.

An excellent all-around receiving set incorporating three "Lemnis-Coils" as the main tuning units can be construct-

trouble in any radio store. They are:

Three Gen-Win "Lemnis-Coils" (they come packed in laboratory tested kits of three); three .00035 mfd. straight line frequency condensers, with suitable dials to fit their shafts; a 7 by 24 inch panel, with an 8 by 24 wood baseboard; six standard tube

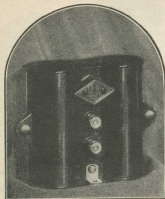

Patents Pending

GEN-WIN LEMNIS coil

Reg. App. U. S. Pat. Off.

To get all that any set can give, you must use this greatest scientific advancement of all—GEN-WIN Lemnis-Coils. They give astonishingly better results because they are the only inductances offering you all these advantages:

- 1—Lemnis-Coils are wound with an elongated reverse curve. This form confines the electro-magnetic field and neutralizes the tendency toward oscillation. The extraordinary length of the curve reduces the resistance otherwise encountered in small diameter coils.
- 2—Lemnis-Coils have no "peak." They afford high, uniform amplification on all wavelengths in the broadcast band. They do not cause distortion.
- 3—Lemnis-Coils amplify only what is received from the preceding stage. Their non-pick-up qualities reduce the annoyance of static and other interference.
- 4—Lemnis-Coils are kept free from dust by means of sealed Bakelite cases, thus retaining their full efficiency.
- 5—Lemnis-Coils used to replace any type of tuned radio frequency transformers or antenna couplers, will increase the sensitivity and selectivity of your receiver.

GENERAL WINDING CO., Inc.

214 Fulton Street, New York, N. Y.

Send This Coupon If Dealer Has No GEN-WIN Lemnis-Coils

GENERAL WINDING COMPANY, Inc.,
214 Fulton Street, New York, N. Y.

You may send me one guaranteed Kit of three GEN-WIN Lemnis-Coils, complete with blue-print, showing detail of hook-up.

Enclosed is money-order for \$12. (Ship postpaid).

Send C. O. D. (I will pay postman \$12 plus postage).

It is understood that these coils are guaranteed to afford the utmost in tuned radio frequency reception.

NAME

STREET and No.

CITY STATE

sockets; three .5 mfd. fixed condensers; three resistance coupling units; five 1 megohm and one .5 megohm resistances; grid condenser and leak; one $\frac{1}{4}$, one $\frac{1}{2}$, and one $\frac{3}{4}$ ampere amperites; battery switch; single circuit telephone jack; binding post strip; and the usual odds and ends of screws, busbar wire, etc.

The set is assembled in two units, the panel and the baseboard. On the panel are mounted the three variable condensers, the battery switch, and the telephone jack. The condensers are spaced along the horizontal center line, one in the exact center of the panel and the other two $3\frac{1}{2}$ inches from the sides. The switch goes in the lower right hand corner, the jack in the lower left. This part of the work is simple, as it involves the drilling of only a few holes.

Four additional holes should be drilled along the bottom edge of the panel, $\frac{1}{4}$ inch up from the edge itself; these are for the screws that hold the panel against the edge of the wood baseboard.

After the panel instruments have been mounted, the unit should be laid aside and work started on the baseboard. The arrangement of the parts is plainly shown in the various accompanying photographs.

The three Lemnis-Coils are screwed to the board so that they will fit comfortably behind the three variable condensers on the panel. One tube socket is placed so that it will fit between the first and second condensers and another between the second and third. These are for the radio frequency bulbs, and occupy positions that make their connection wires very short.

In the extreme upper right hand corner of the baseboard a third socket, for the detector tube, is fastened down, with the $\frac{1}{4}$ ampere amperite on its right hand side. The grid and plate binding posts of this socket should be faced toward the panel, and the wires to them will fall naturally in place.

The three remaining sockets are then placed along the back edge of the baseboard, with even spaces between them. In each of the spaces is then

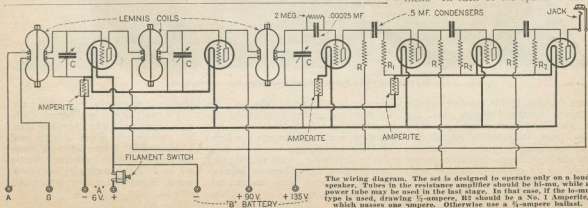

The wiring diagram. The set is designed to operate only on a loud speaker. Tubes in the resistance amplifier should be hi-mu, while a power tube may be used in the last stage. In that case, if the lo-mu type is used, drawing $\frac{1}{2}$ -ampere, R2 should be a No. 1 Amperite, which carries one ampere. Otherwise use a $\frac{3}{4}$ -ampere ballast.

placed one of the .5 mfd. fixed condensers and one of the resistance coupling units. As will be noted in the photographs, a little room must be left along the middle section of the back baseboard edge for the binding post strip, which is raised above the wood about three inches by means of simple brass brackets. The strip should have its aerial and ground posts on the left (looking at the baseboard from the panel) side, and its "B" posts to the right.

The $\frac{1}{2}$ ampere ampereite is now screwed down a little to the right and in front of the middle Lemnis-Coil, and the $\frac{3}{4}$ ampere one in the corresponding position on the left of the same coil.

With all this done, work can be now started on the actual wiring. By way of suggestion, the baseboard parts should be wired as completely as possible before the panel is screwed permanently in place, for if the panel is fastened first and the wiring attempted later, the job will prove a decidedly awkward one. About 90 per cent. of the wiring must be done on the baseboard instruments, and only a few connections will require installation on

the panel once the baseboard has been disposed of.

The wiring diagram is very plain, and needs little explanation. It will be seen that the $\frac{1}{4}$ ampere ampereite controls the filament of the detector tube, the $\frac{1}{2}$ ampere one the filaments of the two R.F. tubes, and the $\frac{3}{4}$ ampere one the three audio amplifiers at once.

The variable condensers are connected directly across the secondaries of the three Lemnis-Coils. Care must be taken that the stationary plates of the variables go to the grid posts of the tubes, and the rotary plates go to the filament. If the reverse order is used, the set will display "hand capacity" effects; that is, the movement of the operator's hands near the dials will affect the reception.

Standard six-volt tubes, working on a regular six-volt storage "A" battery, may be used throughout, though it is recommended that high Mu tubes like the Veby be employed in the first and second stages of the resistance amplifier. A regular 135-volt "B" is also needed, it being tapped at 90 volts for the last audio, R.F., and detector bulbs.

The great uniformity of the Lemnis-Coils makes the dials of the three condensers read almost exactly alike for any particular station. Their overall efficiency makes the set as a whole work beautifully, especially on DX. To select several DX stations of some thirty-six tuned in during two nights of listening, the dial readings were 70 $\frac{1}{2}$, 71, 70 for WMBF, Miami Beach, Fla.; 69 $\frac{1}{2}$, 69, 69 for WGY, Schenectady; and 89, 89, 89 for WIP, Philadelphia. It is actually possible to hear a station on each dial setting, because of the wave channel allocations and the straight line frequency characteristics of the receiver.

This set was made in the laboratory of Walter J. McCord, at 57 Dey Street, New York City, and although the particular location is known to be an extremely poor one, being surrounded by skyscrapers and the elevated railway, the outfit brought in one out of town station after another. As for the purity of the tone quality and the faithfulness of reproduction—well, you simply must hear the set to really appreciate it.

Your Set May Be Down, But It's Never Out

(Continued from page 152)

made, actually does space the stations evenly over the entire dial scale, a highly desirable feature. But here is a point of great importance. These condensers are expensive, due to the difficulties attendant upon their construc-

straight-line frequency condensers.

This conversion is made possible by means of an ingenious arrangement of two sets of gear trains. The two gear trains move independently of each other in such a way that, while

wave-lengths to be separated on the scale and to bring stations of higher wave-lengths closer together. This dial is easy to mount, no drilling of holes being at all necessary and it is indeed fortunate for those who desire selec-

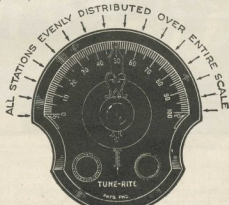
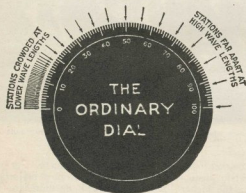

At the left shows how stations are crowded on the ordinary dial and at the right shows how stations are spaced when using a Tune-Rite dial.

tion, and above all they are very bulky.

There is now, however, on the market the Tune-Rite straight-line-frequency dial which, when applied to any existing radio receiver equipped with ordinary condensers, converts it in such a way that the stations are separated evenly over the dial scale, being otherwise possible only with

one moves a pointer at a uniform rate over the graduated scale of the dial, the other train rotates the condenser. This latter gear train comprises eccentric gears, which work in such a way that at the lower readings of the pointer the condenser moves slower than the pointer. This, as can be readily seen, causes the stations at low

tivity that there is in existence such a device, that can accomplish with little expenditure and in a few minutes' time all that rebuilding a set would accomplish. We thus see that there is a cure for every ill that radio is heir to and far from any set being down and out it can easily be brought up to top notch.

A Plain Talk on Tone Quality

By GEORGE V. ROCKEY*

FROM the beginning of broadcasting until the past eighteen months, the demand of the broadcast listener has been for distance and volume. Tone quality was practically unheard of. Today distance has been relegated to the background—85% of the owners of receiving sets tune in on "local" stations within a few hundred miles of their homes. Radio has long since

of instruments; the harmony, which brings out the true beauty of every selection, is carried by the other instruments of the orchestra, particularly the instruments of low pitch. Alone the melody sounds thin, is without depth, and, while it "tells the story," it lacks the depth of feeling which characterizes the rendering of the complete orchestra.

been able to hear the bassoon—the kettle drums?

Lost Music from Poor Amplification

To illustrate just what is being lost in many radio receiving sets now on the market, as indicated in the photograph shown herewith. Every instrument in this orchestra is needed for the

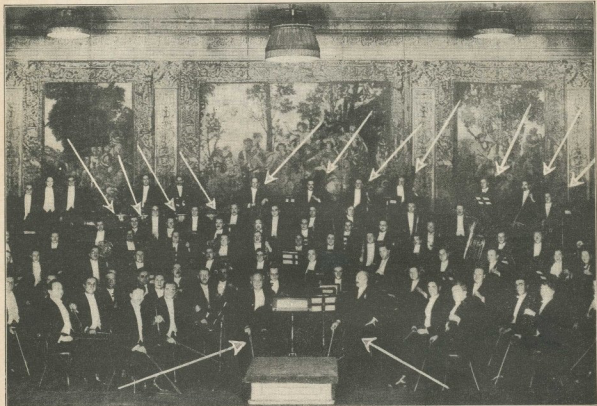

The arrows point to the musicians whose instruments are not or barely heard when the ordinary type of transformer coupled audio frequency amplification is used.

ceased to be a toy, it has become an almost necessary adjunct to American home life, supplying Inspiration, Education, Entertainment. The wonder that music could be caught out of the spaces and translated into music has become commonplace—the question of distance has become secondary—tone quality and appearance have taken the places of distance and volume.

The Meaning of Tone Quality

In all musical selections the melody or theme is carried by one or a group

of instruments; the harmony, which brings out the true beauty of every selection, is carried by the other instruments of the orchestra, particularly the instruments of low pitch. Alone the melody sounds thin, is without depth, and, while it "tells the story," it lacks the depth of feeling which characterizes the rendering of the complete orchestra.

Thus the real beauty of orchestra and band selections are lost. How many times does a piano recital sound flat? How many times have you heard the deep, resonant, pealing notes of the organ? How many times have you

portrayal of perfect music. As far as the reproduction from a majority of sets is concerned the musicians indicated with arrows might as well not be in the orchestra—you will never hear them. And many other musicians in this orchestra might also better not be there for the beautiful notes from their instruments are slurred and distorted.

This is why there have been complaints against the tone quality of the present receivers. A receiver which

will reproduce all of the bass notes without distortion will solve the question of tone quality. And this is not only possible, but is a reality.

The Audio Amplifier the Seat of the Trouble

Every radio set may be divided into three parts: the tuning circuit, which receives the radio waves; the detector which changes them from high, inaudible frequencies to low frequencies which can be heard by the human ear and, the audio circuit, which amplifies

or refined, and another transformer-coupled system was used. The only thing that transformers had to recommend then was more volume. The question of distortion meant nothing. To the dot and dash listener, distortion made no difference—a dot was a dot, and a dash was a dash, no matter how they were distorted. So the first method of audio amplification, the resistance coupled method, was forgotten and disregarded.

When broadcasting came into being, transformers were known, they had been improved and so naturally enough they were used for amplifying the audio waves.

Three years ago, realizing that, if radio was to achieve the same popularity as the phonograph, the engineers resurrected the old resistance coupled method and started to improve and perfect it.

Last year resistance coupled amplification again made its bow to the general public in a new guise—an audio amplifier which amplifies *all* of the music without distortion. It is now possible, by the use of resistance coupled amplification to hear broadcast programs just as they are played in the studio—all of the bass notes come through without being distorted or slurred, the true harmony is preserved, giving any musical selection that depth of tone which is produced by the broadcasting orchestra.

The Use of Special Power

Tubes

Engineers who had been conducting experiments with resistance coupled amplifiers were fully acquainted with the fact that ordinary 201-A tubes were not suitable for resistance-coupled amplification. After years of effort, they succeeded in perfecting a new tube such as that now known on the market as the Daven MU-20. This tube has an amplification factor of 20, which is greatly in excess of the usual all purpose tubes such as 201-A tubes. With resistance amplification, it is absolutely necessary to use the MU-20 tubes in order to get the best results. This cannot be stressed too strongly.

Just as it is so necessary to use these special tubes in the first two stages of a three-stage amplifier, it is equally important to use the special power tube such as the MU-6 power tube in the last or output stage.

How to Get the Most Out of Your Set



Learn the principles of radio from this remarkable book
514 PAGES

Compiled by HARRY F. DART, E.E., Formerly with the Western Electric Co., and U. S. Army Instructor of Radio Technically edited by F. H. DOANE

STOP turning the dials blindly. Learn what happens when you turn them and why. Then you get greater distance, greater volume, most enjoyable quality. The I. C. S. Radio Handbook will help you to get more enjoyment out of radio. It clears up the mysterious — tells you just what you want to know. Written by nationally known radio authorities in language that you can understand. An absolute necessity for every radio fan. A wonderful bargain at \$1. Note this partial list of contents—

Electrical terms and circuits, antennas, batteries, generators and motors, electron (vacuum tubes), many receiving hook-ups—radio and audio frequency amplification, broadcast and commercial transmitters and receivers, super-regeneration, licenses, etc.

Send only \$1 with the coupon today and get this 514-page I. C. S. Radio Handbook.

Money Back if Not Satisfied

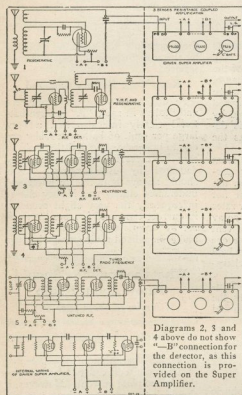

Diagrams 2, 3 and 4 above do not show "B" connection for the detector, as this connection is provided on the Super Amplifier.

Wiring diagram showing how to connect a Daven resistance-coupled amplifier in your set.

the audible waves and transmits them to the loud speaker where they are translated into music. Any properly constructed tuning and detecting circuit brings into the radio set all of the music as it has been broadcast from the studio. It is what happens to the radio impulses *after* it has left the detecting circuit that makes or mars the reception. The audio circuit is the troublemaker—and must be improved if radio is to have the popular success it deserves.

Years ago when inventors were making their experiments to improve the reception of code, they discovered the method of Resistance Coupled Amplification. This method brought the signals in clear and sharp, but with the growing demand for more and more distance—and with it naturally more and more volume, this method was dropped, without being developed

International Correspondence Schools
Box 7571, Scranton, Penna.

I enclose \$1. Please send me—post-paid—the 514-page I. C. S. Radio Handbook. It is understood that if I am not entirely satisfied I may return this book within five days and you will refund my money.

Name.....

Address.....

Check here and enclose \$1.50 instead of \$1 if you wish the De Luxe Leathered Edition

RADIO DEALERS **BIG DISCOUNTS**

WHOLESALE RADIO

Radio promises big record-breaking season. Make the most of it by getting our Catalog before you buy. Huge stocks of standard radio parts, wire, kits, ready for quick shipment at rock-bottom wholesale prices. Windfall sale on sets, tubes, batteries. Ask for free copy!

W. C. Braun Co., 32-78 S. Clinton St., Chicago, U.S.A.

PATENTS

PROMPTLY PROCURED SEND A SKETCH OF YOUR INVENTION FREE INVENTION RECORDING BLANK

NAME.....

ADDRESS.....

Z. H. POLACHEK
PATENT ATTORNEY
70 WALL ST.
NEW YORK

MAIL TODAY

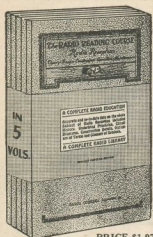

PRICE \$1.97

A RADIO EDUCATION

IN 5 VOLUMES

Theory, Design, Construction,
Operation and Maintenance

LEARN AT HOME

These five component parts of a complete Radio Instruction Course are outlined in five volumes that contain not merely the essentials as so many books do, but more, they contain all that any modern up-to-the-minute textbook on any subject would cover. They are in themselves a COMPLETE radio education teaching every possible portion of Radio science.

Size of each book 6 by 9 inches, handsomely bound and illustrated with charts, diagrams, descriptions of equipment, etc.

SEND NO MONEY for these books. Just forward your name and address. We send you the books at once. On receipt of same you pay the postman \$1.97 plus a few cents postage and then they are yours.

Distributed by

The Conrad Co., Inc.

64 Church St., New York, N. Y.

Most people have the idea that a power tube will give more volume than an ordinary tube. This is absolutely erroneous. The term "power tube" means just what the phrase implies—a tube to handle more power. If an ordinary tube is used and the

power turned on, the tube will load up and the loud speaker will produce a series of squeals and grunts. The power tube, on the other hand, will take care of this excessive power and will feed the audio waves to the loud speaker clearly and without distortion.

How to Get the Most Out of Your Storage "A" Battery

(Continued from page 109)

fastened in place. If these contacts are not perfectly made, charging may not be normal and the operation of the set may be irregular from this cause.

The wires leading to the storage battery should be rubber covered without braid. Braid is attacked by the storage battery spray and is destroyed in a short time whereas the rubber covering is immune.

While the gases that escape from the storage battery in charging, particularly at the end of charging, are hydrogen and oxygen which are not in themselves harmful, the higher rates of charge draw up also a fine spray which leaves a coating about the vent tubes at the end of charge. The eye of the operator should never be held close to the vent opening during charging for this reason.

Hydrogen gas is, of course, inflammable and explosive as it leaves the battery cell and an open flame should never be held over the storage battery vent at any time. Use an electric bulb held so as to illuminate the interior of the cell when you are adding water, with the eye at least two feet away from the cell.

The electrolyte is dilute sulphuric acid which is harmful to fabrics and to the finish of furniture. Should it exude or be spilled in any way it may be neutralized by throwing baking soda on the dampened surface and when the bubbling ceases, wiping off the surface with an old cloth. An old cloth dipped in ammonia water should also be used for drying the top of the battery after filling with water and after charging.

Routine Charging

Assuming that the user is supplied with a normal 80 ampere hour battery and a commercial charger of standard make usually charging at either 2½ amperes or 4 to 4½ amperes; on a five tube set in the average home, the battery should be charged at least overnight once in ten days. If the charger is rated at 2½ amperes it should remain on charge about 20 hours. If the charger is rated at 4 to 4½ amperes it should remain on charge about 14 hours. This is, of course, not a

fixed schedule and must be adjusted by the user to meet his conditions of service.

Keep Your Battery Charged

Actual experience of manufacturers and dealers in radio "A" storage batteries clearly indicates that a very large per cent. of battery troubles are due to undercharging and that only in rare instances is the storage battery damaged by overcharging. Users should always bear this in mind and understand clearly that if they charge infrequently the very slight economy in current consumed is more than offset by unsatisfactory radio reception and a short-lived radio storage battery.

What the Beginner Should Know About Radio

(Continued from page 88)

other words, greatly amplify a weak impulse.

A small variation of the potential in the grid circuit causes a large variation in the plate current. However, it should be noticed that these two circuits are quite separate and it should also be borne in mind that the energy in the plate circuit is not supplied by the incoming grid voltage, but merely controlled by the latter. The energy in the plate circuit comes from the battery and is only released by the action of the grid of the tube.

By a relaying system the small amount of energy in the grid circuit releases a much greater amount of energy in the plate circuit, which is then utilized instead of the smaller amount of energy that is coming to the tube. Of course, the amount of energy that can be controlled by one tube has a limit, but if greater amplification is desired several tubes can be connected together by suitable means and each one can add its own part to the building-up process, until finally we have a huge amount of energy resulting from a small initial input. This is the manner in which an amplifier system operates.

The Use of Resistance in Radio Sets

By E. R. STOCKLE, Ph.D., Member A.I.E.E.*

IT is well known that a circuit including a coil and a condenser is capable of electrically oscillating, provided that its resistance is low enough. If an electromotive force is suddenly applied to such a circuit, the current which flows will not immediately reach a definite value, but will over-shoot its final value and oscillate back and forth a number of times before reaching a steady flow. If the resistance of the

introduced by the vacuum tube is equal to or greater than the positive resistance of the circuit then the circuit will generate sustained oscillation.

This very valuable property of the vacuum tube becomes a great source of trouble in radio receiving circuits, which are made up of a number of tubes capable of supplying energy to a number of tuned circuits. It is the chief cause of the oscillation control

needed to avoid oscillation prevents the nice adjustment of the vacuum tubes which will give enough regeneration to compensate for resistance losses in the circuit at all frequencies. This seriously decreases the efficiency of the receiver, particularly in getting distant stations. If the counter electromotive force of this method were adjustable at the will of the operator, so that the set could be operated close

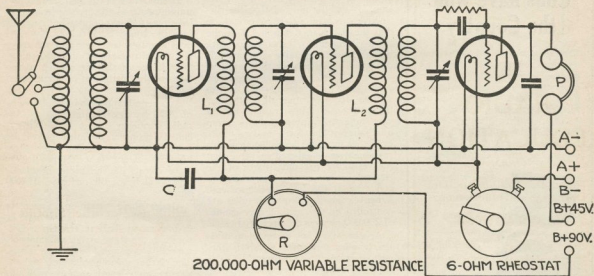

A portion of a five-tube tuned radio frequency circuit showing the use of plate voltage control to prevent the vacuum tubes from generating uncontrolled oscillations.

circuit could be reduced to zero, the electrical oscillation thus started would continue for a very long time and would die out slowly as energy is radiated from the circuit in the form of radio waves. It is therefore apparent that resistance is a detriment when inserted in an oscillating circuit, since it dissipates the energy of the oscillating current.

One of the chief purposes of the vacuum tube in modern radio circuits is to compensate for the resistance losses in the oscillating circuits. The vacuum tubes supply energy from the plate battery at the proper frequency and phase to make up for the resistance losses in the circuit. For this reason the vacuum tube is often called a negative resistance device, since its effect is the same as though resistance were subtracted from the circuit: If the energy supplied by the tube to the circuit more than compensates for the loss of energy in the circuit, or in other words, if the negative resistance

problem with which all designers of tuned radio frequency circuits must contend. Many schemes have been provided to prevent the vacuum tubes in a tuned radio frequency circuit from generating uncontrolled oscillations. These schemes may be divided into three classes.

1—The introduction of proper counter electromotive forces through inductance or capacity coupling.

2—Introduction of losses sufficiently great to prevent their compensation by the vacuum tube.

3—The method of limiting the supply of plate voltage to the vacuum tubes so that they cannot furnish enough energy to generate oscillations.

The first of the above mentioned classes is exemplified by Neutrodyne and so-called Reversed Feed-Back circuits. It has had a great popularity for about two years, but as generally put into practice sacrifices one of the great advantages of the vacuum tube. A circuit which is permanently bal-

anced to the oscillation point to give maximum efficiency at all wavelengths, this method would be one of the very best. As commercially produced, however, this is not accomplished.

The second of the above methods has a large number of representatives, among which are the introduction of resistance into the grid circuit, absorption circuits, the potentiometer control, etc. This method, while not necessarily decreasing the efficiency of the receiver, usually results in broader tuning. The introduction of a resistance loss into a freely oscillating circuit is generally not good radio practice, even when vacuum tubes are included to compensate for this loss.

The third of the above methods has been given commercial attention only within approximately the last year, and it is the purpose of this article to set forth the ideas underlying this circuit. In this method the resistance used for oscillation control is, not electrically a

*Chief Radio Engineer, Central Radio Laboratories.

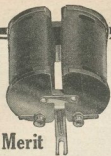

On Their Merit

POWER-PLUS

Coils have won the Country

The newest coil on the market—yet the one most in demand. Surely such popular acceptance throughout the country has been won by proved superior performance. POWER-PLUS Fieldless Coils actually give the radio fan real selectivity. Tuning is easy—*not* critical; naturally it's easy to select one station and stick to it. Distant stations come in clear and loud.

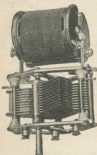

POWER-PLUS Coils and Condensers are new departures in their fields. They are new in design, in construction, with many distinct advantages. The POWER-PLUS Kit-Set—3 Coils and 3 Condensers—offers the best in radio.

FREE — 7 Hook-Up Blueprints

Surely you want to know more about POWER-PLUS Coils and Condensers. Ask our dealer near you—or clip and mail the coupon below. Seven copyrighted Hook-up Blueprints will be sent to you FREE.

A. F. Henninger Corp.
4503 Ravenswood Avenue
Chicago, Ill.

part of the freely oscillating circuits, but is simply used to govern the voltage which is supplied to these circuits.

A diagram of a five-tube tuned radio frequency receiver employing plate voltage control method is shown in the diagram. In designing this circuit, all the well-known precautions for positioning the coils and otherwise eliminating feed-back between successive stages, should be used. If this is not done the amount of resistance which is necessary in the plate circuit might be so great as to decrease somewhat the efficiency of the radio frequency tubes. In general, the type and arrangement of coils used in the Neutrodyne and other tuned radio frequency circuits makes a very satisfactory design. It will be noticed that the distinctive feature of this circuit is that the primaries L1 and L2 of the radio frequency transformers are brought together and a resistance R connected in series with them and the positive "B" voltage. This resistance must have a high value in order to provide the required range of control for the voltage. It further must have a wide range of variation, that is from maximum value down to practically zero. It is also desirable that this resistance be so tapered in value that the resistance per unit length of the element be less at the low resistance end than at the high resistance end. When two radio frequency tubes are controlled by this method a resistance of 200,000 ohms is the preferred value.

Another very important element is the by-pass condenser which is connected from the Positive "B" side of the radio frequency transformers to the filament. This condenser should have a value of about one microfarad or a one-half microfarad condenser may be connected across each of the R.F. tubes. It will be observed that this condenser provides a path for the oscillating plate current so that this current is not obliged to pass through the high resistances. In other words, the primary of the radio frequency transformer, the vacuum tube, and the condenser C provide a closed circuit whose greatest impedance is that between the plate and the filament of the vacuum tube itself. The D.C. voltage applied to the plates of the radio frequency tubes is governed by the value of the resistance R and at any given frequency just enough voltage is applied to the plates of the tubes to compensate for resistance losses in the oscillating plate circuit. As the fre-

quency to which the receiver is tuned increases, the energy fed back through the grid to plate capacity of the tubes, and also through the inductive coupling between stages, increases. This causes an increase of energy compensation to the point where the receiver will go into uncontrolled oscillation unless additional resistance is inserted at R. It is thus possible for the operator to adjust the energy supplied to the radio frequency tubes by means of the resistance R so that the set will operate at its most sensitive regenerative condition. This will permit the greatest range of reception and also will provide adjustment for best quality.

It should be noted that this circuit, unlike many of the resistance controlled circuits, does not introduce any loss into the tuned circuits. It therefore does not interfere with the efficiency nor the sharpness of these circuits. This is one of the outstanding advantages of this method of oscillation control.

Another advantage is in the economy of "B" battery consumption of the radio frequency tubes. When the circuit is properly designed it will be found that at frequencies below three hundred meters the resistance in the plate circuit of the radio frequency tubes will be of the order of 100,000 ohms.

Under these conditions the plate current taken by these tubes will be as low as one-half milliampere, compared to the eight or ten milliamperes normally consumed by these tubes. The large volume obtained on the shorter wave-length stations with this very small plate current consumption is one of the surprising characteristics of this circuit. It results directly from the fact that the control resistance does not dissipate the radio frequency energy but supplies just enough direct current voltage to the oscillating circuits to allow the tubes to operate at their greatest efficiency.

This circuit has been discussed at some length because it is an illustration of the proper use of resistances in radio circuits. In conclusion it may be stated that in order to obtain maximum efficiency from a radio receiver, resistances should not be included in any of the circuits which carry oscillating current, since this generally results in broadening the tuning and lowering the efficiency of the receiver. Variable resistances used as a means of governing the energy supplied to the oscillating circuits in a receiver are among the most satisfactory devices for accurately controlling the regeneration and oscillation of vacuum tubes, and when properly designed they give the operator perfect control over the tubes in his receiver.

RADIO CATALOG AND HOOK-UPS FREE

Our most new catalogue, fresh from the press, contains the very latest in vacuum tube parts and accessories—hundreds of amazing bargains. \$50,000 customers testify by our wonderful return and complete satisfaction with diagrams for making most practical portable sets. **FREE SEND QUICK** for your copy. (Please include name of friend who is interested in Radio.)

THE BARAWIK CO., 162-132 S. Canal St., CHICAGO

A. F. HENNINGER CORP.,
4503 Ravenswood Ave., Chicago, Ill.

Gentlemen: Kindly send me your folder and seven copyrighted hook-up blueprints. I understand that they are absolutely FREE—and that I am not obligated in any way.

Name

Address

Town State

Correct Aerial Installation

By S. W. HULL*

PERHAPS no part of the average radio equipment receives less attention than the aerial. In reality, it is one of the most important factors of your radio outfit.

All radio receivers have an aerial of some kind for it is the only means there is of collecting the radio energy and directing it into the set.

Of course some aerials are better than others. The most desirable ones being those that collect the most energy. By that is meant the weak waves from stations hundreds of miles

about 100 feet long. It should be about 35 to 40 feet above the earth, or if placed on a building it should be about 20 feet above the roof.

These clearances will in both cases place the aerial where it will be in po-

radio energy makes the matter of height an important one. Height therefore is your first consideration.

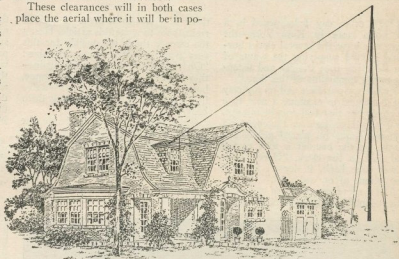

Illustration by courtesy of S. W. Hull & Co., Cleveland, Ohio.

Fig 1

A correct single wire aerial installation.

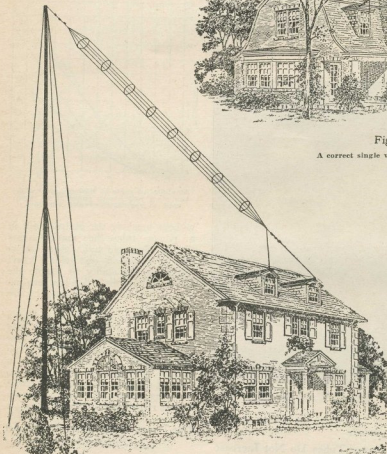

Fig. 2

A typical installation of a cage antenna.

away, whose wave energy has become weakened by travel over great distances.

The ideal aerial for such work is a single No. 14 stranded copper wire

sition to get the full energy of the radio wave, before it has lost energy through absorption due to treetops or other interference.

The fact that all objects absorb

Fig. 1 is a typical illustration of the proper way to install an aerial, using a standard steel "Hercules" Aerial Mast.

Note how the mast places one end of the aerial well above the roof and treetops. The other end of the aerial is secured to the gable of the house, by a screweye.

The lead-in is a continuation of the aerial wire—this eliminates a splice. Energy is lost at all splices, try not to make any.

It will be noted that the antenna is double insulated from the top of the mast and also the gable roof.

The Mast should be equipped with a mast-head pulley so the antenna may be raised or lowered at will. The mast-head pulley should be galvanized and the pin on which the pulley wheel turns should be brass so it will not rust or wear.

The guy wires should be galvanized and about $\frac{1}{8}$ " in diameter. The mast should be of substantial construction, preferably of steel. The Hercules Aerial Mast for instance uses a special high strength pressed steel section to give proper strength and at the same time reduce the weight—so it can be erected easily.

(Continued on page 172)

Power Tubes for Audio Amplification

What They Are, Why They Are Used, and How They Should Be Used

By GEORGE V. ROCKEY*

THE other day I happened in a radio store in New York—the place was busy, the several clerks hurrying around supplying the wants of the soldering iron welder and listening to the complaints of the “bug.”

I made my purchase and on my way out I stopped to examine a new type of condenser that had caught my eye. As I was lingering over the counter a customer came in, placed gently but firmly, on the counter a tube carton and said to the clerk, “Here’s your power tube back, it doesn’t increase the volume of my set a bit.”

After some conversation the man was refunded his money and he walk-

thing will have to be done. I decided right there to write this article. Here’s the answer that’s responsible for this very popular article on power tubes: “Oh! it’s those power tubes again—they are supposed to increase volume, but for some reason they don’t—we’ve had a lot of trouble with taking them back.”

That answer is very evidently the reason why power tubes have been slow in taking hold—too many of them come back—because they weren’t sold correctly in the first place.

Entirely too much technical and semi-technical data has been written about the new power tubes and but

the story in a nutshell. Put an ordinary OI type tube in the last audio stage of any set and turn up the power; up to a certain point the tube will function perfectly. After that the tube will overload and oscillate and the tones will become muffled and distorted. The more power you turn on, the more distortion you will get. Now take out that ordinary tube and



Above is shown three tubes which are especially designed for use in a resistance coupled amplifier. The one standing upright is a power tube for the last stage.

ed out feeling friendly toward the store, but mighty unfriendly toward power tubes.

After he had gone out, I engaged the clerk in conversation and after we had talked condensers for a little while, I said, “What was the matter with the tube that man returned a little while ago?” The clerk’s answer made me sit up and take notice—if that’s a fair example of the general misinformation on power tubes, some-

very little which the layman could understand.

Power Tubes Do Not Increase Volume

Power tubes were properly named in the first place—they are tubes designed to carry more power or juice or whatever you want to call it, without distortion. If power tubes were designed to give more volume, they would be called volume tubes. That’s

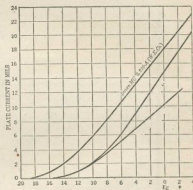

Amplification curve of MU6 compared with two other well-known power tubes when used in resistance coupled amplifier.

without touching the controls, put in a power tube—the music comes through clear and full without distortion or oscillation—the volume hasn’t increased—the ability to handle the power without distortion has been improved. That’s the purpose of the power tubes.

It’s the same principle as putting a high powered automobile engine in a jitney chassis and stepping on the gas: the light chassis will shiver and vibrate. Now put that engine in a sturdy chassis and use the same amount of gas—the same horsepower is being generated, but the sturdy chassis remains firm without vibration.

Use Power Tubes Only in the Last or Output Socket

Power tubes were designed for one purpose—to improve reception by permitting more power to be used without distortion. They should be used only in the last or output stage of the audio frequency end of your receiver. They are not a cure-all, but when used properly

(Continued on page 174)

*Daven Radio Corporation

A Modern Method of Filament Control

An Efficient Means of Simplifying Radio Set Operation Through the Use of the Self-Adjusting Rheostat

There are people who still remember the early days in the automotive field, the days of "cranking her up," when it needed at least one double-up man power and a sprained wrist to start the blamed thing. How far off those days seem now, when no one would dream of buying an automobile that wasn't equipped with a self-starter.

But a problem far more serious than that confronting the automobile industry faced the radio industry when it became a question of how to build a



Illustration of Amperite and mounting.

radio set, which would be simple enough for the layman to handle who has no mechanical knowledge, even as most people are now able to handle an automobile or a phonograph.

Be it remembered that radio burst upon an unsuspecting public with a rush such as had never been seen before or since. Radio, which constitutes the greatest achievement of the present century, found millions of people ready to enjoy it—but a comparatively small number sufficiently trained to operate a radio set. Not before the handling of a radio set could be made so simple that even a child could operate one, could the industry hope to attain that degree of popularity which it is just beginning to reap.

Hence simplicity of operation became the guiding star of everybody connected with the radio industry, and tremendous strides have been made in this direction.

One of the most vexed questions was "how to safeguard the tubes," the correct operation of the tubes being, of course, the very essence of proper reception. Many are the perils to which the tubes are exposed at the hands of the inexperienced operator. Rheostats, to control the tubes, which are all right in the hands of experts, though experts often experience difficulty with them, proved a source of unending trouble in the hands of the layman. Consequently, a great deal of effort has been directed toward the elimination of hand-rheostats.

It would be underrating American ingenuity to assume that this difficulty

could not be solved, and concurrent with the evermore insistent demand for simplified operation, it has been solved by the self-adjusting rheostat such as the amperite. This has been to radio what the self-starter has been to the automobile. It not only makes the set equipped with it easier to operate, but actually makes it foolproof.

There are, however, still a large number of what—for want of a better term—may be called the Rip Van Winkles of radio, who are unaware of this development, and it is for their benefit that information about it may be worth while.

Right amperes are a *sine-qua-non* of proper radio tube operation, a condition ordinarily brought about by the more or less frequent adjustment of a hand-rheostat, to the end that the current flowing through the tube may always be of the right amperage. Requiring great dexterity, blow-outs are often the result of hand-rheostat operation, hence the self-adjusting rheostat came as a veritable godsend to the layman as well as the expert, since



Schematic diagram showing how Amperite is connected in the filament circuit of a vacuum tube.

it takes over in its entirety the function of the ordinary rheostat.

The tubes are the most important fact in the set, and to operate them at their highest efficiency it is essential that the tube filament gets neither too much current, which would damage it, nor too little, which would impair its efficiency. To achieve perfect tube-performance it is necessary to introduce a variable resistance in the filament circuit, *i.e.*, either a hand-rheostat, by means of which the operator can increase or decrease the current at will, or a variable resistance such as Amperite, which is self-adjusting and exercises this function automatically.

By way of demonstration let us first take an ordinary kind of wire and see how it acts under the influence of elec-

tric current. As everybody knows, the electric current heats up the wire, causing it to emit both light and heat. We have here in fact the principle on which electric heaters and incandescent lamps work. But a wire or filament, subjected to electric current, in-

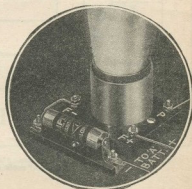

Picture diagram showing connection of Amperite to tube socket.

creases its resistance to the current as it heats up. This is called the thermoelectric characteristic of the wire, and the change of resistance when heated differs considerably in all kinds of metals or alloys. Look at the tungsten vacuum lamps burning in your home. Irrespective of their wattage or voltage all burn at the same temperature. This is not merely a coincidence. Every tungsten vacuum lamp is carefully designed to operate at that definite temperature. Why?

The life of any vacuum tube depends upon the life of the filament. The best scientists and metallurgists in the world spent many years in trying to develop a method to make tungsten into fine filaments. The difficulty lay in the fact that tungsten is very hard and brittle; it was like trying to draw an eggshell into wire.

Nevertheless a process was finally developed which changed the eggshell-like structure of tungsten into tungsten that could be drawn into wire of less than one-thousandth of an inch in thickness. It is this kind of tungsten, which is used in modern radio tubes, and in order to keep this tungsten-filament in the proper ductile form for giving best results it must be operated at a definite temperature.

Contrary to popular conception the lamp will not last longer if burned at a lower temperature. Doing this in fact changes the filament to the eggshell

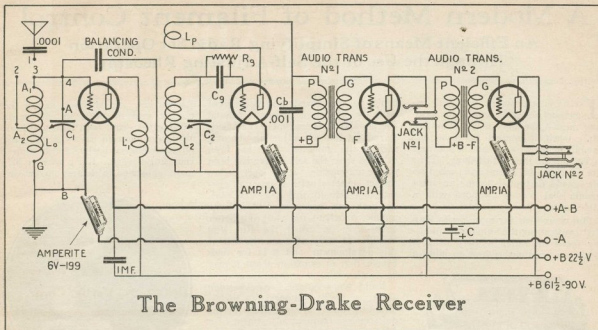

The use of amperites is shown in this diagram of the Browning-Drake Receiver. This popular circuit, which combines regeneration and balanced radio frequency, is selective, has plenty of volume and will bring in distance.

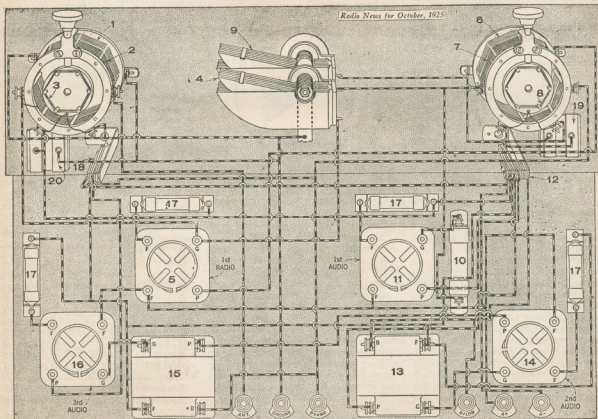

structure and any slight vibration breaks it. On the other hand, if the tube is operated above the proper temperature, the filament is rapidly vaporized and the tube may be burned out. It is evident, therefore, that the temperature and current must be kept within a very narrow range.

There are, however, certain kinds of wire, consisting of metallic alloys, which possess the quality of increasing their resistance under heat to such an extent as to exactly counterbalance a voltage across the filament. If then a voltage applied to such a filament is increased, the wire simply heats up a little more and increases its resistance, so that, even with a higher voltage, only the required amount of current can flow and no more.

It is a filament of this kind of metallic alloy of which Amperite consists and which adjusts the current automatically. It is contained in a hermetically sealed glass tube, filled with an inert gas, which prevents damage to the tender filament operating under the aforementioned thermo-electric principle. It has, as already indicated, the unique property of automatically changing in resistance as the "A" battery voltage changes, thereby maintaining an even flow of current in the tube filament.

This is most clearly demonstrated when we observe the current passing through a set, which is operated on a freshly charged battery. The current tends to rise above the point for which the tube is designed, a condition which calls for adjustment. It is effected automatically by the self-adjusting rheostat, whose filament at once heats up. It thus increases its resistance and decreases the current that can flow through its filament to the tube with which it is connected. It is obvious, therefore, that a tube, which is connected to the right kind of filament resistance, never becomes overheated or gets out of commission. In this connection it is well to remember, what has already been indicated, that, if a tube filament draws only a very small overload of current, its life will be considerably shortened and replacement of the tube becomes necessary long before its due time.

On the other hand when, in course of operation, the battery potential becomes weaker, as the charge of the battery decreases, the self-adjusting rheostat again takes care of this by decreasing its resistance through cooling off. It thus once more allows the proper amount of current to flow through the tube filament, until the battery becomes exhausted, when the tube naturally won't function.

Simplified operation of radio sets has at all times been the principal aim of all radio experimenters, and the self-adjusting rheostat is one of the biggest steps towards that goal.

2200-OHM HEADSET \$1.89 PLUS POSTAGE



They embody precision in adjustment, accuracy of balancing, nicety of spacing.

Special alloy magnets, 4 in a cup.

No. 40 best enameled wire coils, triple strength leads.

5 ft. 24 strand cords, polarity indicating.

Extra light weight headband.

Ear caps best insulating material, moulded to ear.

Metal parts heavy nickel plated.

Loud, clear, permanent with plenty volume. Regular \$5 value.

Sent on receipt of price, \$1.89 plus 10¢ postage.

The Union Sales Co. ^{Box 121} Derby, Conn.



All who are thoroughly informed on the sound science of advanced radio principles are quick to recognize in Apex Vernier Dials qualities that are imperative to the utmost of Radio utility value and beauty of appearance.

APEX VERNIER DIALS

provide widest possible range of selectivity and a degree of positiveness seldom acquired. Greatly increase the usability of any set and bring in those distant stations that are a joy

to every true radio enthusiast. Positively no back lash. Artistic design. Ratio 12 to 1. Adaptable to any 1/4 inch condenser shaft. Handsomely finished in: Royal Brass, \$1.50; Satin Silver, \$1.75; DeLuxe Gold (24K) \$2.50, list.

APEX RHEOSTAT DIALS

are designed with an inimitable touch of beauty that imparts a tone of elegance to the most attractively designed set. Size 2 inches. Fit any 1/4 inch shaft. Royal Brass Finish, 60¢—Satin Silver Finish, 70¢—DeLuxe Gold (24K) 80¢, list. Complete descriptive matter upon request.

APEX ELECTRIC MANUFACTURING COMPANY

Quality Radio Apparatus

1410 West 59th Street,

Dept. 245,

CHICAGO

RADIO STUDY AT HOME

EXPERT

YOU EARN WHILE YOU LEARN

Dept. 19, Hurst Bldg., Chicago, U. S. A.

Big Money for Radio

Desired for high pay radio men is so great that a big Kansas City wholesale concern is now filling men free to get into the radio business for themselves and make \$50 to a week without any capital invested. Select territory open. Send today for free catalog and sample offer. Write direct to Mr. H. J. Sutton, Standard Radio Co., 124 E. 12th Street, Kansas City, Mo.

DEALERS-BIG DISCOUNTS

**WHOLESALE
RADIO
SUPPLIES**

Make more money by getting into radio. Our big catalog shows huge stocks of standard radio parts, sets, kits, at lowest rock-bottom wholesale prices. Fast service. Guaranteed profit. Thousands of dollars profit per service. Wonderful special offers on sets, tubes, batteries. Get your free copy NOW before you buy.

W. C. BRAUN CO. 32-25 S. Clinton St. Chicago, U. S. A.

Ask your newsdealer to save a copy of RADIO REVIEW for you.
THE CONRAD CO., INC. 64 Church Street, New York City

The Elky Tube Equalizer System

A Method Which Uses Any Combination of Tubes

By JOSEPH KAUFMAN*

RADIO tubes have undergone numerous changes in the past few years and as a result there has been no standardization of the sockets or of the filament voltages. Now, how-

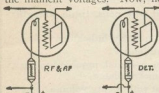

The diagram on the left shows an Elky Resistor in an audio frequency circuit, while the one on the right shows the resistor used to control the filament of a detector tube.

merely adapting the proper Elky Resistor.

The arbitrary selection of the storage battery is due to obvious causes. In the first place it is estimated that 90 per cent. of all filament supply is from this source; then again, it is the logical source from the standpoint of economy. It is not only a very expensive practice to operate the five-volt tubes from dry cells, but it is actually impractical. It is, therefore, only natural that the six-volt source should have been adopted by the large tube manufacturers.

As an example of the development

as radio frequency or audio frequency amplifier. In the latter instances they are particularly advantageous, eliminating a rheostat control and permitting the tubes to operate at their rated current and voltage.

The Elky Resistors will prove a great convenience with the new UX-112 tubes. This new tube operates at one-half ampere and five volts. One of the Elky units can be used with this tube in the last stage of an audio amplifier and if the tube should be changed, it is merely necessary to change the type of resistor.

Radio enthusiasts who are continu-

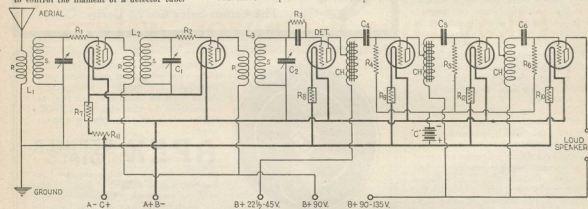

Here is shown a circuit diagram of a six-tube radio frequency set using the Elky Equalizer System. The types of resistors used for various types of tubes are as follows: R-7—(2-UX199 tubes)—type 23 Elky Resistor. R-8—(1-UX199 tube)—type 50 Elky Resistor. R-9—(1-UX201A)—type 4 Elky Resistor or (Mu 20 tubes)—type 0, R-10—(Mu 6)—type 0, or UX112—type 2 Elky Resistor. R-12—(Mu-30)—type 0, or (UX201A)—type 4 Elky Resistor.

ever, with the advent of the new Radio Corporation UX types, a definite step has been taken in the direction of a universal mounting. This system will obviate the necessity of making radical socket changes in the receivers built to accommodate former types of tubes.

In addition to the movement toward standardization of the bases used with vacuum tubes, the tendency is to arrive at a universal input voltage. Irrespective of the input voltage, if we adopt a standard source of current such as the six-volt storage battery—assuming that the maximum required voltage is slightly below that point—a system of resistors can be used to adapt any tubes according to their operating voltage and filament current requirements. With these pre-adjusted resistors in the positive or negative filament lead, no rheostats are required and tubes can be changed at will without any of the former difficulties regarding rheostat values by

of such resistors, the Elky Tube Equalizer System assumes a six-volt storage battery source and provides



A single Elky Resistor is shown at the left and a bank of four of these resistors is shown at the right.

suitable resistors to adapt any of the tubes to any circuit. Among the various types are units for a single tube of the UX-201A, UX-199, UX-112, UX-120, MU-20, MU-6 types, or for several tubes of either type, as for instance, two tubes used

ally trying new circuits will find these resistors a great aid as several different types of tubes can be used to obtain the benefit of their particular characteristics, permitting them to be changed at will. The receiver is thus not limited to any particular type of tubes. If, for example, two standard radio frequency stages are used, a resistor can be obtained for regulating the current and voltage to any of the tubes best fitted to this kind of amplification; the detector tube can be controlled by another unit; the amplifier for the audio frequency currents can be of the resistance coupled type, using three tubes. Two of these may be the MU-20 or other similar tubes operating from individual resistors, and the output tube may be the MU-6 or similar type controlled by a separate automatic resistor. It is then possible to change to any other tubes without loss of time or change in the receiver.

(Continued on page 168)

*The Langbein-Kaufman Radio Co.

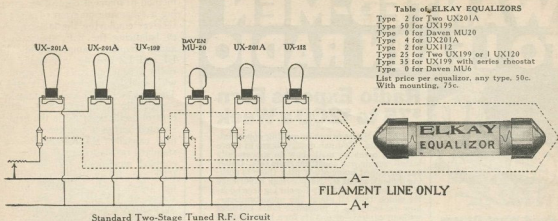

Use Any Combination of Tubes with the Elkay Tube Equalizer System WITH FULL TUBE PROTECTION

IN the 6 tube circuit above, note the wide diversity of tube types and voltages. Under the Elkay Tube Equalizer System such a circuit will operate smoothly and at the very maximum of tone quality, volume and selectivity.

The Radio Corp. UX tubes go far toward standardizing tube mountings. They do not, however, provide for tubes of different voltages. With a definite, standardized input voltage, by inserting Elkay Equalizers in the negative or positive lead (according to the characteristics of the circuit position) a system is born that permits reduction of each tube to proper working voltage.

As the Radio Corp. and practically all other tube manufacturers have adopted a 6-volt source as standard, the Elkay Tube Equalizer System is designed to work on this input.

There is an Elkay Equalizer for use individually with every tube made. There are also Equalizers to control two tubes from the same source—a particular advantage for two stages of R.F. or two stages of Audio where both tubes operate together continuously. Obviously, where, with automatic filament jack, one of the tubes is turned off individual Equalizer should be used.

With the new UX 112 tube, taking .5 ampere at 5 volts, the Elkay Tube Equalizer System proves especially effective. Type 2 Elkay Equalizer equalizes it when used singly in the last stage, and type 4/3 equalizes it when used in cascade with a UX 201A tube.

Set manufacturers are turning to resistance coupling because of the wonderful purity of tone, and many types of tubes have appeared for this purpose. The Elkay Tube Equalizer supplies an Equalizer which equalizes these tubes singly or in cascade at 6 volts.

Engineers have long employed resistors in detector and audio stages because these stages are not critical, but they have hesitated about R.F. circuits. We shall be glad to show how Elkay Equalizers may be used with great success in the R.F. stages, with either potentiometer or series rheostat. Another thing, it is well known that, with UX 199 tubes in the R.F. circuit, it is not sufficient to limit the upper value of current to normal value. With a Type 35 Elkay Equalizer in series with a rheostat an adjustment 20% above and below normal may be had.

Write for further details.

ELKAY
5-Tube
SUPER
RESISTOR
with
Resistance
Coupling

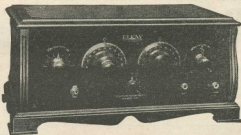

Equipped
with the
ELKAY
TUBE
EQUALIZER
SYSTEM

Uses any type of tube without change of wiring. Operates on dry cells or storage battery. Circuit contains one stage of R.F. detector, one stage of transformer coupling, and two of resistance coupling.

Has control for selectivity; also for oscillation. Low wave lengths can be brought in as easily and as smoothly as high. Patented ELKAY CLARIFIER clears up muffled signals to full brilliancy. Exact logging.

This circuit is the result of four years' development work. The tone is superb and it separates conflicting stations with "needle-point" accuracy.

Handsome, two-tone mahogany cabinet, beautifully designed and appointed. Price \$80. With 4 tubes, not resistance coupled, \$70. 5-tube kit, \$65. 4-tube kit, \$60. If not at your dealer's, write us. Set of blue prints for either set, \$1.

To the Trade: Write for Exclusive Franchise

The Langbein-Kaufman Radio Company, Dept. W, 511 Chapel Street, New Haven, Conn.

An LK Product



WANTED—MEN TO LEARN RADIO



**Read What Others
Have to Say About
Our Training**

Makes 100% Profit

I have not finished your radio course, but I am already paid for itself several times.

I am now building sets at a profit of over 100 per cent. In addition to the profit on the set I get another \$12.00 for installing it. That's not so bad, is it?
Yours truly,
(Signed) Harry E. Watson, Pa.

Income Increased 300%

After completing your course I started my own radio business. My income is 300 per cent more than before I enrolled as your student.

I find the course "just the thing" in my radio work, for it covers every practical point that comes up. I can recommend it most highly to anyone interested in radio. Sincerely yours,
(Signed) K. O. Benzler, Iowa.

Earns \$50 a Week in Spare Time

As a result of your training I have been able to earn over \$50.00 a week in my spare time. During the coming season I hope to do much better.

I am recommending your course to all my friends, and by this way show my appreciation for lifting me out of the low pay class. Very truly yours,
(Signed) Werner Eichler, N. Y.

Passes Radio Examination

I have passed the amateur radio examination; station call letters T.K.K.
Yours truly,
(Signed) Alex H. Sokoloff, Washington

RADIO ASSOCIATION OF AMERICA.

4513 Ravenswood Ave., Dept. H-2 Chicago.

Please send me details regarding your Expert Home-Training Plan and offer of a 100-mile Radio Set FREE.

Name _____

Address _____

City _____

State _____

Radio Experts Earn \$75 to \$200 a Week

Look into the easy money-making opportunities in Radio. You can quickly learn in spare time—at home by mail—how to successfully install, repair, and construct radio sets. Under our simplified home-study plan there is nothing difficult about it. No previous experience is necessary. Send today for our big free booklet which tells all about the opportunities—how to build up a profitable radio business without capital—or qualify for a high-salaried position with the U. S. Gov't, the Steamship and Railroad Companies, and the thousands of corporations needing trained men.

1000-Mile 3-Tube Receiving Set Given with the Course

This latest model, high-powered three-tube receiving set is now supplied new members without extra cost. Has a receiving radius of 1,000 miles—performs equal to sets selling at \$50 and up. Head radio engineer Mohaupt's guarantee to teach you how to make sets as fine or better to sell at a good profit. This is a special offer subject to withdrawal at an early date—so act promptly.

"I pledge my personal attention to every member enrolling in our Association at this time. Your individual problems and questions will be answered by me, and I will work with you at every stage of the course, guiding you till fully trained, including Government examinations for Operator's license."

A. G. MOHAUPT

Mr. Mohaupt, head of Radio Association of America, is a Graduate Electrical Engineer, University of Wisconsin; former Radio Instructor for the U. S. Government; author of "Practice and Theory of Modern Radio."



A. G. MOHAUPT, B.A., M.S.

Mail the Coupon NOW! Get all the facts. Act before the special free receiving set offer expires. Let us prove to you that radio is easier to learn and offers biggest money than any other business or profession you can get into.

To illustrate the flexibility of this method of filament control we are giving a schematic diagram of a six-tube receiver employing the latest methods of balancing the R.F. stages and of audio frequency amplification. Coils L1 and L2 are the customary tuned radio frequency coils in conjunction with variable condensers C1 and C2. The resistances R1 and R2 may be set—generally about 600—800—ohms to control oscillating; R3 is the grid leak shunted across a condenser of .00025 mfd. capacity; R4, R5 and R6 are the standard resistances used in impedance coupled amplifiers; R7, R8, R9 and R10 are Elky units according to the tubes used; (UX-199 for R.F. stages or UV-199 for detector and 3UV-201A's for audio amplifier will make an excellent combination). R11 is a rheostat of about 10 ohms to vary the R.F. voltage below the operating level, giving control of volume; C4, C5 and C6 are stopping condensers and CH, CH, CH, are the chokes or auto transformers. An arrangement of this sort is very economical to operate and offers exceptional quality of tone.

If the builder wishes to employ resistance coupled amplification for the audio stages, few changes will be necessary. The chokes CH, CH, CH, can be replaced by resistances and Elky Resistors of the proper value to control respectively, two MU-20 and one MU-6 tubes.

Loud Speaker Uses Newly Discovered Principle

(Continued from page 148)

other portion is a special impregnated parchment for the low notes. The metal, being harder, is better able to reproduce the rapid variations while the parchment reacts to the slower vibrations which produce the low notes—thus combining the basic principle of the finest violins, cone type speakers and basic laws of sound reproduction.

One of the most noteworthy features of the loud speakers using this diaphragm is their reproduction of notes of the extreme lower register such as the low notes of an organ or bass drum. The same is true of the high notes of the violin. Loud speakers using this new type of diaphragm appear to strike a new and better note in reproducing apparatus.

THE HAWKEYE REMINDER CLOCK

"Watchful of the time"



A handy clock, small enough to be held in one hand, hangs flat against the wall, or set on the table or dresser. You can instantly set it to any one minute from one to ninety, and at end of time and five minutes the alarm will answer and stopped by touch of a lever. Of great service to
Factories, Bakers, Laundries, Doctors, Photographers, Etchers, Enamellers, etc.

Make a guaranteed by reliable clock makers. Good time keeper, and can be used as a regular alarm clock to ring by.

Hawkeye Clock Co., Muscatine, Iowa

WE ESTABLISH YOU,

(an honest man in each locality), regardless of your handicaps, in your own fascinating, profitable, permanent radio business with the best internationally known products.

ARCE LUNA & COMPANY

Dept. RE, 154 Nassau St., New York

RADIO— BARGAINS

FREE RADIO CATALOG & GUIDE of newest ideas, over 100 approved special book-size with illustrations. Thousands earlier on standard radio parts, sets, kits. Be sure to get this thirty book before you buy. Wonderful Unusual You'd say so. Write letter or postal NOW. SARAFIK CO., 125-132 S. Canal St., CHICAGO, U.S.A.

DEALERS BIG DISCOUNTS

Radio's biggest season is here. Get our new catalog showing huge stocks of radio parts, sets, kits at lowest rock-bottom prices. Quick service. Wonderful special offer on best sets, tubes, batteries. Write for free copy.

W.C. Braun Co., 32-78 S. Clinton St., Chicago, U.S.A.



Ask your newsdealer to have a copy of RADIO REVIEW for you.
THE CONRAD CO., INC., 64 Church Street, New York City

The Three Circuit Tuner

By REUBEN H. GROSS

The Old Reliable Radio Set for Broadcast Reception

FATE has been kind to us throughout the several years of broadcast listening-in to which we plead guilty, and still remain the simon-pure B.C.L. as of yore. What a blessing it is to continue along without trying to delve into the innermost secrets that lurk behind the whole "mystery" of delivering entertainment via ether. We are quite satisfied to learn our lesson by what comes out of the horn of the loud speaker or thru the phones. Doing sufficient of this will eventually teach the veriest tyro enough to enable him to form an opinio as to which circuit has the best punch and which brings in the elusive DX stations. So has it been with us. We have turned dials on all types of receivers from the simple crystal set to the complicated super "what-not"—have burned the early morning oil both winter and summer and have met with old man static in all of his varying moods.

Please don't be misled. This recital will contain no lengthy discussion on the scientific phases of radio. The reasons are simple. Primarily, we know nothing about the radio laboratory and like millions of others are not keenly interested therein, except where theories promulgated by laboratorians fail to check up with experiences in front of the dials. Secondly, we are willing to admit our mental deficiencies (along these lines only however) and concede that the language of microfarads, millihenries and fractions thereof is foreign and most difficult to learn, except perhaps in its barest fundamentals. Again we are like millions of others and must learn our lessons from nothing more than the set as it functionates before us.

How well do we remember the first experience with the crystal set. What a thrill it was when the strains of what seemed to be the most beautiful music in the world came over, and we were entranced. And so, too, there still rings in our ears the laughs of friend

wife, who thought it so ridiculous and said so, to see a big, fat, grown-up man playing with a toy that almost fit the palm of his hand. So too, there lurk pleasant memories of the single circuit squealer which was followed by the three-honey-comb coil set that brought in the elusive DX stations and which later still reposes intact upon a shelf in the "shop."

Of course, we had a neutrodyne. Who didn't own one about two years ago? We thought we had the utmost

tube affair which we succeeded in getting into a 26-inch panel and over which fact we gloated with keen delight. We thought that the greatest thrill in radio had come to us when we owned this giant. Not alone did we get a station on plenty of places on the dials, we also blew all eight tubes at once when a screw-driver accidentally slipped into the works while the batteries we connected. What a thrill!

Funny influence this radio disease has on one, what? Almost like telling

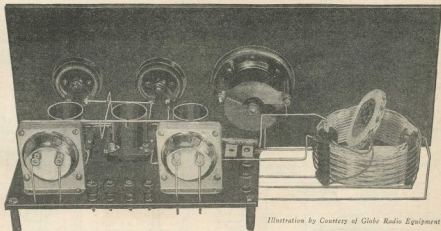

Illustration by Courtesy of Globe Radio Equipment Co.

A back panel view of a three circuit tuner employing a transformer coupled radio frequency amplifier.

in receivers at that time and rejoiced accordingly. By the way, our first one still lives and is doing daily service for a friend who refuses to become infected with the virus of the radio bug, and continues satisfied with what he has. What a strange creature! How diligently we followed instructions in how to "neutralize," and how eloquently we cursed when the darned thing wouldn't "Neut." We even tried striking the same pose as did the man in the book during this most difficult operation, and finally admitted our inferiority.

How many failed to get set-up with the super-het? To you fellow bugs, who admit the failing, we say go back and try it. The sport of matching tubes and deciding whether it shall be air-core or iron-core transformers is something that you cannot afford to have missed, else the cycle will have been broken and your radio biography differ from ours. Ours was an eight

a new listener about the operation in which you nearly but not quite died. The point of this tale is almost lost in the length of the story. Incidentally we built a three circuit tuner and hence the title of this most valuable contribution to the infant science. Economy must be practised, even by the radio bug, and having enriched the tube manufacturer through the medium of the super-het, the exchequer demanded immediate retrenchment. What a vast difference in the size of the bill when we purchased the three tubes necessary to put life into the plot of this narrative. And speaking of economy, isn't it remarkable how gallopingly the "B" battery juice is consumed with a multi-tube.

As may be readily deduced, by this time in our radio experience, we had learned the lesson of cheap parts. To the neophyte, let us admonish you to learn this lesson and thus avoid suffering the experiences for which we

paid so dearly and so often. There is no such thing as a good, cheap radio part, and it is well we know it. Now that we have preached, back to the story. Out we went and bought, "Low loss" parts and built us a "Low Loss" set. At this stage, it again becomes necessary to preach. Look to the laboratory for help in securing

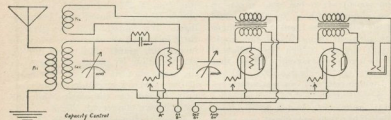

Schematic wiring diagram of the three circuit regenerative set with two-stage transformer coupled audio amplifier.

real "Low Loss" material. How much junk has been foisted upon poor, unsuspecting victims as "Low Loss," no one will ever know. Don't buy anything that has not met the tests of the experts engaged in doing this service for you, through the medium of the laboratory, and your "shop" will never have to tolerate the pile of stuff that has accumulated in ours.

No, there's nothing new about the hook-up used in the three circuit tuner

we are permitted to express our opinion frankly, so here goes. The ethics of radio authorship demands that details of coil building be furnished to the amateur from the method of insulating the wire to the threading of the screws used therein. Not being bound by this code let us say that we have yet to see the amateur who could do justice to such a job, unless perhaps he had the facilities of the coil maker's factory, and even then we still ques-

haps it is our lack of skill more than the coil.

Study the photograph which shows the coil wired into the set. You will notice that the primary is made of bare copper wire and surrounds the secondary. This wire is gold plated which makes it immune to the action of the elements and eliminates corrosion of the metal. This feature means little or nothing when tuning locals, but when the elusive DX station remains elusive, it is often the factor which brings in the music or voice.

The secondary of the tuner is tuned

by a .0005 mfd. variable condenser. This too is of the "low loss" type and should have a vernier other than the plate variety. We have found that plate verniers are not as efficient as the others and are a means of increasing losses in the operation of the set. A vernier dial of good make is excellent. We have discovered something about insulated wire which we, in our big-hearted manner will reveal to the world. Look at the wire on a new coil and notice how bright and shiny it is. Now take a piece of insulated wire which has been used in a coil during one summer in a climate such as is found in and around New York City. Carefully unwind the insulation. The bright sheen on the metal

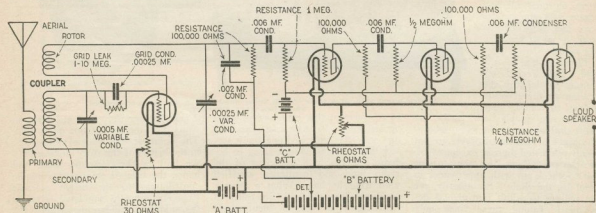

Schematic wiring diagram of the three circuit tuner showing how a three stage resistance coupled amplifier can be employed. This arrangement is ideal for tone quality reproduction.

er. Look over the diagram that accompanies this and you will see much the same as when you first built the three honey-comb coil set. The values of the coils and the wave length range is fixed in the new outfit, otherwise, the resemblance is apparent. The use of an aperiodic primary in this circuit is excellent and if you are careful about the size of your antenna, it is as selective as could be desired, even by the most critical. Don't get it over 100 feet, including the lead in and all will be well. In large apartment houses found in big cities, those living on the lower floors are compelled to use longer lead-ins and thus will have an

tion. Our advice is to go out and buy a ready-made, factory-built coil, but make sure that you are getting one that will do all that is claimed for it. That's exactly what we did, and while we had some slight disappointments, we finally got what we wanted, and at last we are, or we think we are, riding on top of the radio world.

There are two types of three circuit tuners. One has a tuned tickler and the other has a fixed tickler which is tuned by a variable condenser. Both coils have their advantages, with a slight inclination to the latter type. We find that it is more easily controlled than the movable coil, but per-

is gone and instead we have a dull piece of copper covered by oxide or sulphide as the case might be. We are told in the primers on radio that the minute electric currents which go to make up our infant, move over the surface of the wire. Inasmuch as the new coating on the metal is a non-conductor, the surface of the wire is no longer available for carrying impulses. Thus there are more losses with which to contend. This is easily overcome however, by using enameled wire which is covered by both cotton and silk. We have found such a coil and are now using it. Our hopes for increased efficiency are hastened.

A word about the tickler in the 3-circuit tuner and then our tale nears its end. This part of the coil is the means of controlling regeneration and since regeneration is the principle on which the circuit is based, the tickler is deserving of much more attention than is usually accorded it. The variable tickler with its small diameter wire surely gives the punch to the set, and if properly used, brings in the DX stations so that the family can really hear the concert without having you act as interpreter or conductor. On the other hand, this innocent looking bit of apparatus is responsible for more annoyance to neighbors than even old man static himself. If you must tune a station by the whistle of the carrier wave, then do so as quickly as possible. Don't keep the set howling while you make your adjustments. Remember that while you are doing this, all others listening on the same wave-length in your neighborhood are being cheated out of hearing the program. This nuisance has caused many a cuss word to be heaped upon the head of the offender, and matters reach their most horrible state when some other fellow starts squealing back for revenge. This often leads

GLOBE LOW LOSS TUNING COILS

"It Was Only Possible With Your Coil"

says E. F. Walter of 41 Van Buren St., Brooklyn, N. Y. "It has been during the past few weeks that I realized more than ever that I had the goods in your coil, as the enclosed list testifies.

"But the climax came last night. While tuning for DX I picked up WRC Washington on 469 meters. A slight twist of the dial and I got a faint whistle. With a little more care in tuning I heard a man singing with piano accompaniment, and when the selection was over I received the thrill I have been waiting for for the past 4 years—Station KFI, Los Angeles, Cal., operating on 468.5 meters."

Los Angeles, Cal. and WRC Washington, Both Operating With Less Than 1 Meter Apart, Received in Brooklyn, N. Y.

Such performance can only be assured when you use THE PATENTED GLOBE LOW LOSS TUNER.

The total cost of parts used in Mr. Walter's set was less than \$20

29 Distinctive Patented Features
Easy to install. Ask your dealer or send for descriptive circular.

GLOBE RADIO EQUIPMENT CO., 217 West 125th St., N. Y.

GET THE RESULTS
And Over 40 Magazine and Newspaper Radio Laboratories Know It.

HERE ARE THE REASONS

They conform in every manner to the Standards set by prominent Radio Engineers.

Wound on Air. This saves the energy which is ordinarily robbed by the use of tubing used in most coils.

Large Wire. Little resistance for the currents.

Low Distributed Capacity. More selective.

6 Small Screws, the only Metal used in its construction, reducing the losses still more.

Where **Corrosion** is the direct cause of many Radio sets going stale after several months of use, GLOBE COILS are safeguarded by the use of Enameled wire in the secondary and the bare copper Primary is heavily plated with 24 Karat Gold.

others into the scrimmage and the first thing you know, the entire community shuts down their sets and radio is again blackened, with special em-

phasis on regenerative sets.

The advantage of the fixed tickler which is tuned by a .00025 mfd. var-
(Continued on page 174)

7x18"

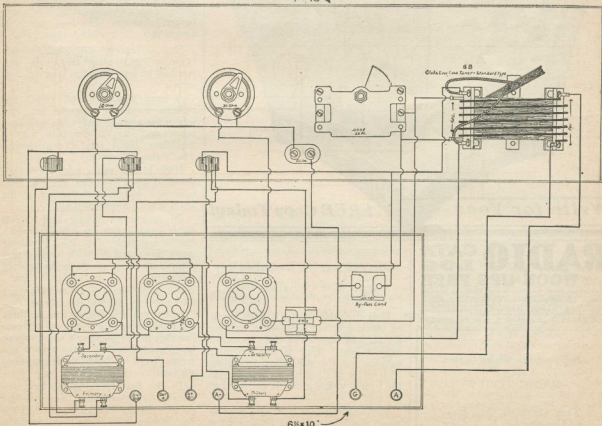

Complete picture layout and wiring diagram of the three circuit tuner as shown in the accompanying photo. This set employs a standard transformer coupled audio frequency amplifier.



TESTED PARTS

All parts offered in our catalog including those combined in knockdown KITS have been carefully tested and approved by our graduate Radio Engineers. Satisfactory results are guaranteed!



PANELS FOR KITS

A completely drilled and engraved panel is included with each of our kits. Makes set building easy and sure. No other concern gives this FREE service.

Just Out!

OUR LATEST 1926 FREE RADIO CATALOG

BEFORE you build be sure to consult our latest 100 page Radio Catalog. A dependable guide for set builders. Knockdown sets and kits for all the latest circuits. No finer or more complete assortment to be found anywhere. Latest designed parts. And the prices—every one quoted means a big saving for you!

Write for your **FREE copy today**

CHICAGO SALVAGE

509 S. STATE ST.,

Dept. RR6

STOCK STORES

CHICAGO, U. S. A.



Write for Your

FREE Copy Today!

RADIO CATALOG AND HOOK-UPS FREE

Our great new catalog, fresh from the press, contains the very latest in complete sets, parts and accessories—hundreds of exciting bargains. 280,000 customers testify to our wonderful value and reliability. Complete instructions and drawings for making most popular sets **FREE**. **SEND QUICK** for your copy. Please include names of friends who are interested in Radio.

THE BARAWIK CO., 102-102 S. Canal St., CHICAGO

Ask your newsdealer to save a copy of
RADIO REVIEW
for you.

THE CONRAD CO., INC.,
64 CHURCH ST., N. Y. CITY



BLUE PRINTS

Complete **BLUE PRINTS** and easy-to-understand **INSTRUCTION BOOK** included with each of our **KITS**. No technical knowledge required to build your own set.



SAVE MONEY

Our enormous buying power permits us to pay spot cash and get rockbottom prices. Be sure to see our catalog before you buy—save money. Write for your free copy today.

around it, leaving a stem about 4 feet long with a loop on the end. This block should be buried about 3 feet below the surface, with the loop above the earth. The guy wires are fastened to this loop.

The earth anchors are usually spaced away from the mast a distance equal to 1/3 the height—for instance on a 40-foot mast they are spaced 13 feet 4 inches out. Three anchors are sufficient, generally two back of the mast and one in front.

The mast itself is set in a hole about 18 inches deep. The bottom of this hole should be lined with stones to prevent the mast from settling in damp weather.

Fig. 2 shows a cage antenna. This presents greater area and more surface to the radio wave and will therefore gather more energy than one wire.

Such a cage should be about 75 feet long. It is generally made of six No. 14 stranded copper wires. The ends are soldered together and securely attached to insulators at the end nearest the mast.

The rings should be about 12 inches in diameter and made of 3/4 inch round brass rod, soldered neatly at the splice.

These rings are spaced about 6 to 8 feet apart. The aerial wire is soldered to the rings—taking care to have the wires spaced equally about the rings before soldering. The best way is to fasten them first with a little wire.

Slow and careful, neat and thorough is the way to go about this work—and you will be satisfied with your finished aerial.

A good aerial is well worth the trouble it takes to make it. For where the average radio fan gets 1 ng range occasionally—the man with a first-class aerial gets it consistently. That's the difference.

High priced radio sets often may prove disappointing or even a total loss to a would-be radio fan, if his aerial is not properly put up.

Of course an indoor aerial "will work" and it is even found convenient in many cases to depend entirely upon the small portable aeriels that come with some of the higher priced receivers.

But when you stop and consider that the antenna is the big hand that "reaches out" into the air and captures the radio waves for you, you will realize that the loop antenna can no more be compared with a large outside antenna than a rowboat can be compared with a modern ocean liner.

In the first instance the loop antenna will "catch" things for you, and so will the outdoor antenna. But the comparison stops about there, just like the row boat will keep you on top of the water and so will the ocean liner.

Correct Aerial Installation

(Continued from page 163)

It is desirable to use a good grade of black graphite paint—and to give the mast at least three coats to insure against rust. Pipe is not desirable because of the possibility of filling with water at the base and rusting on the inside, unless a cup is provided at the top.

Earth anchors for fastening the guy wires are best made by cutting off a piece of 2 x 4 lumber 12" long and wrapping a piece of the guy wire



FREE All the Latest HOOK-UPS

and CATALOG of newest PARTS—Kits— Sets at BARGAIN PRICES

You have been waiting for this book. It's a real guide for the fan and set builder—and it's a real money saver besides. Shows all the newest hookups and gives constructional data, constants, etc. Also the latest, most advanced apparatus, including parts, sets, kits, and accessories at BIG SAVINGS. Latest 1926 Edition.

Write Today for Your Copy. Simply send us your name and address and also please include the name of friend interested in Radio. We send you your copy of this big valuable book absolutely FREE. Send at once.

BARAWIK CO.

102-132 S. Canal St.
Chicago, Ill.



Mail this Coupon:

Name
Address
Name & Address of Fan

Analyzing the "Diamond of the Air"

(Continued from page 147)

value would result in a lower effective voltage. To compensate to a certain degree for this additional resistance and increased drop, the applied plate voltage is increased to 150 volts, wherever it was 90 volts with transformer coupling. In fact, if it is desired to apply identical effective voltages it is necessary with resistance coupling to use approximately 200 per cent. higher applied voltages.

What the Curve Shows

A graph showing how the output is increased when the applied plate voltage is increased is shown herewith. From this curve one may observe the difference between an applied voltage of 90 and 150. And fortunately with this type of amplification the increase in plate current is not proportional to the increase in plate voltage, being very much less. The following values are cited:

At 400 volts the output of the unit was rated as 72 and the drain was .8 of one mil. At 150 volts applied, the output was increased to 172, but the current advanced only .315 of one mil to a total drain of 1.15 mils. With

150 volts applied to the audio tubes the total plate current drain of the entire audio amplifying system was 13.9 mils. Of this 11.5 mils was the drain of the output tube, and 1.2 mil for the first and second audio stages. It should be remembered that no biasing batteries were used when these values were ascertained. This high rate for the last tube is due to the replacing of the plate coupling resistor by the loud speaker, whose winding has a resistance value about one-tenth of that of a resistor and the effective voltage is higher. Thus the total drain of the receiver is 24.9 mils. Proper design, however, calls for a biasing battery in the grid circuit of the output audio tube. The accompanying diagram embodies this. The grid biasing voltage value as determined by best response was 6 volts negative and the plate current thus was reduced by 5 mils, to 8.9 mils for the last tube. The total drain of B current in the whole set, with "C" battery used, is 19.9 mils, not at all excessive for a 5-tube receiver of this design. This value of bias is used with a plate potential of from 145 to 150 volts with 5-volt tubes, other than the hi-mu type.

Plate Voltage in Resistance

Experiments conducted with various values of plate potential upon audio amplifying tubes utilized in resistance

coupled units showed that 90 volts applied was not sufficient to provide satisfactory, distortionless amplification of loud signals. The advantages that should have accrued due to the use of resistance coupling were lost entirely, through insufficient effective plate voltage. With 90 volts applied to the plates of tubes coupled with 100,000-ohm resistors, the effective voltage is about 25 to 30, depending upon the tube impedance, and experimenters have generally found that 25 or 30 volts are anything but sufficient for the plates of an audio amplifier. This is the reason for the poor operation of many resistance coupled amplifiers. The lower the effective voltage, the shorter the operating characteristic curve, and the more tendency for the grid to swing positive, at which time distortion cannot be avoided. By increasing the effective plate voltage, this characteristic curve is lengthened, until grid voltage fluctuations cannot swing the grid positive, and distortion from that angle is eliminated.

Resistors Stand 150 Volts

It would be well at this time to consider an item found in the audio circuit that is closely allied with the plate voltage. This is the plate resistor. Being of the graphite type it is limited in the value of potential that may be applied across it, due to the disinte-

grating action of the voltage upon the carbon granules. If the voltage is excessive this deteriorating action takes place and the resistance of the resistor decreases, resulting in a decrease in the total voltage amplification obtainable with the tube-resistor combination. Experiments with the resistors used showed that 150 volts was the maximum potential which could be applied without causing rapid voltage and resistance fluctuations.

Now, as to the life of the "B" batteries when the potential is increased.

One is very likely to forget that when the plate potential is increased, the plate current drain is increased, because the higher the plate voltage, the greater the current drain of the tube, and when this action is applied to a receiver it is at once obvious that when the output is increased by the application of increased plate voltage, the life of the "B" battery is correspondingly decreased, due to the increased current drain. And this action occurs despite the "C" battery, for the biasing battery is limited in its scope when a modulated input and output are concerned.

This additional drain is of great importance when the "B" batteries are of the dry, non-rechargeable type, since their design does not permit of a heavy overload; nor is the decrease in life proportional to the increase in drain. Doubling the load on a battery of this type will not decrease the life in proportion, the advance towards death being much more rapid as the load is increased. So we see that the plate potential is not as small an item as we might imagine.

Power Tubes for Audio Amplification

(Continued from page 162)

erly, will improve the tone quality and relieve you of many of the distortions of radio.

How to Protect Your Power Tube

Whether you are using transformer-coupled audio amplification or resistance coupled amplification, you should never use power tubes without the proper amount of "C" battery bias. This is not only to protect your "B" battery consumption, but also to help prevent the rapid deterioration of the tube due to the high "B" battery voltage passing through the tube and tearing down the electrons of the plate.

With 45 volts of "B" battery, you should use not less than 4.5 volts of "C" battery. With 90 volts of "B" battery, you should use 4.5 volts of "C." With 135 volts use $7\frac{1}{2}$ to 9 volts of "C" battery

Resistance Coupled Amplification and Power Tubes

Resistance coupled amplification, without question the finest method of amplification known for tone quality, can be made to equal transformer-coupled in volume if the proper and high mu tubes are used. Hi-mu means that the tubes have a high amplification constant. The power tubes combined with the hi-mu tubes have made the method, now generally known as resistance amplification, the peer of all audio amplifiers in every respect. Superior tone quality, not approached by any other method, was always conceded for resistance coupling amplification, as it is now popularly termed. The question of volume is now answered by using two MU-20s in the first two stages and a MU-6 power tube in the last or output stage. This combination will give as much volume as any two-stage transformer-coupled amplifier and without distortion.

So the power tube has given to radio not only an improvement for reception—it has helped give radio the answer to its greatest problem, tone quality. Perfect music, just as it is broadcast from the studio, is now possible, without sacrificing volume.

If the power tube had nothing else to recommend it except that it helped, with the Hi-Mu tubes, to put resistance coupled amplification in the place it deserved, it has served its purpose.

Use power tubes, they will improve your reception; but use them correctly—do not expect to get something they were not designed to deliver.

The accompanying chart shows the efficiencies of the power tubes now on the market. This chart was compiled by Mr. G. F. Usman, a prominent radio engineer, and appeared in the September 25th issue of the *New York Sun*.

The Three-Circuit Tuner

(Continued from page 171)

The coils we used were the two types manufactured by the Globe Radio Equipment Co., and known as Globe Tuners. The variable condensers were the SLF type made by the General Instrument Co. While these instruments are larger than most others, their efficiency is unquestioned. We used resistance coupled audio frequency amplification through the medium of units made by the Polymet Mfg. Co. Three stages of this form of amplification will give sufficient volume for the most critical and the tonal qualities must satisfy even

the fan who insists that he has an aesthetic sense. At one time we were satisfied that transformers were quite good enough but after our recent experience we have learned better.

A word about the grid leak would not be amiss at this time. It is quite remarkable how much this harmless looking bit of apparatus influences reception. The correct resistance in this part of the circuit is essential else you are not getting all that you should into the horn. Try out several from one to ten megohms and you will find that one gives the loudest signals. Bear in mind that when you change your detector tube, the grid leak will have to be matched again.

When you buy tubes, buy only those that are known to be made by reliable makers. "Bootleg" tubes may work, for a while, but their life is short and in the end you are stung even if they cost much less than the genuine article. The OIA type is satisfactory both for detector and amplifiers. We are using X tubes and find them O. K. Have your tubes tested before you buy them and if they meet the standards, you run very little risk of loss. A reliable dealer stands behind anything he sells, including the tubes. A thirty-ohm rheostat controls the detector and a ten-ohm rheostat is used for the amplifiers. Polymet rheostats are in one of our sets and General Instrument in the other. Both serve their purpose very well.

Tuning is simple. The condenser shunting the secondary of the coil finds the stations according to their wavelength and the other dial controls regeneration and volume. Nothing could be simpler than this and if you are patient and willing to study the characteristics of your set, you will soon learn how to handle it. A set, even with the identical parts found in another, will vary slightly from its fellow, and these variations must be noted and used in tuning. After the locals have been mastered, and you have learned to find them easily, then start fishing for DX. Don't expect to do wonders the first time you try. Experience is the best teacher, and time will see you improve. Keep adjusting the grid leak and try various voltages on the plate of the detector tube. This may vary from $22\frac{1}{2}$ to 45 volts depending on the tube. Ninety to 135 volts are used on the plate of the amplifiers. When you learn to hear the faint whistle of the carrier wave of the DX station, it will require delicate adjustment of the dials to bring it in with volume. Having attained the knack, it is remarkable how far out you will reach with this circuit. Don't expect all that you would from a multi-tube.

The Counterphase Receiver

(Continued from page 124)

One, Two or Three Radio Stages

While the Counterphase method is applicable to one stage of radio frequency, giving a very excellent four tube set with practically a single control, and may also be used with two stages for a five tube set, the height of its usefulness comes into play with three stages of radio frequency. In this case the use of Tandem condensers make a two control unit possible. The Tandem condensers have so-called "trimmers" which are used to bring the two circuits into resonance with each other after which they are left in that position for all ordinary tuning but are available when necessary on distant or weak signals in order to bring the same up to full volume.

Great Volume on First Audio Stage

The great advantage of the third

stage of radio frequency of course is that long distant stations may be brought in with only a short indoor antenna. Loud speaker operation on stations up to 500 miles is readily obtainable with an antenna not more than three or four feet long and the fact that the Counterphase method eliminates losses from the grid circuit gives an astounding increase in volume. The result is that the second stage audio is used only on very weak signals; at Chicago for example, it is nothing unusual to tune in Pacific Coast stations on the loud speaker with only one stage of audio, and a consequent increase in quality which cannot be expected when more stages of audio amplification are employed.

All in all it would seem that the Counterphase circuit is one about which a great deal will be heard in

the days to come and that any one who is qualified to construct a circuit using one or more stages of radio frequency will be able to secure exceptional results from its use.

Nine-Color Diagrams Furnished

The manufacturers furnish the same in kits for either five or six tube circuit with a very excellent and instructive set of diagrams, one of the features of which is that nine different colors are employed using a color for each wire and the kits include wire of the same color as that shown on the diagram.

These coils are built in three different styles, one as an Antenna coupler, the other intermediate and the four-circuit style for four tube sets, all coils also being obtainable individually.

The Passing Fallacy of Matching Tubes

(Continued from page 121)

changes will not distort. It has a very low impedance so that the current and lots of it, will flow freely. If it is put into the set without any other changes, not much difference will be noticed. The music you get may come through more smoothly, but you may not now have the volume. You need more plate voltage on the tube. I take it for granted that you've been using ninety volts on all your amplifier tubes. That seems to be most satisfactory. And another 22½ volt block to the special tube., making it 112½ volts on that plate. Now, to smooth it out a bit, and economize on plate current, put a separate C battery on that tube alone, of 13½ volts. You will have increased your volume, and greatly cleared up your reception. You'll really be delighted with the results. If you want more volume make the plate voltage higher still. Add another 22½ volt block, making it 135 volts on the plate. Your C battery should now be 22½ volts. If your set gave you poor quality before, sit back and enjoy it to the full now. If you didn't hear it across the room, you'll sure hear it now.

Now, for your five volt, 201A set you can do exactly the same thing. Your special tube is the Magnatron DC-112.

You will never complain about quality or volume again, I'll wager.

A word about your B battery eliminator, if you have one. You will not deny, I am sure, that a special tube is necessary there, too. Your 201A tube cannot give you the results you want. It was never designed to. How many tubes have you used and thrown away? There are tubes, such as the Magnatron Rex, which are built for that job, and which do it right, though they can't do anything else. They are power tubes with a heavier filament that can stand the gaff. Don't forget that your eliminator tube is handling the current, all of it, that all the rest of your tubes and your loud speaker taken together, are handling after it. It has to be a heavy duty device. Eliminator tubes like the Rex have a very very low impedance so as to carry lots of current, and at the same time with as low a voltage drop as possible. And they have to be very hard

so that they will rectify completely and constantly, without ionizing, choking, over-heating or back-firing.

And that's about enough, just now, don't you think? After a little while we'll be taking up special r. f. tubes. But we haven't quite got round to that in this country yet.

But we will. Sufficient unto the day. Let us all, you and I, keep ourselves informed. Let us take advantage of every new advance that takes place in radio. Let us install into our sets these new ideas and principles as they prove themselves. No need to discard our sets for new ones. No need to be technical experts, either. It's really simple after it's been properly explained. Have I?

RADIO - BARGAINS

FREE RADIO CATALOG & GUIDE of newest ideas, over 100 approved special book-ups with instructions. Thousands available on standard radio parts, sets, kits. Be sure to get this thrifty book before you buy. Wonderful Full Catalog! You'll save on. Write letter or postal NOW. BARAWIK CO., 102-132 S. Canal St., CHICAGO, U.S.A.

Index of This Issue

	Page		Page
Radio Broadcast Stations of the U. S. by Call Letters...	3	Fixed Condensers	116
Radio Districts of U. S. and Canada	20	The Passing Fallacy of Watching Tubes	120
Radio Broadcast Stations of the U. S. by Wave-lengths and Frequencies	23	The Counterphase Receiver	123
Radio Broadcast Stations of the U. S. by States and Cities	39	Notes on Wavetraps	125
Slogans of Broadcast Stations in U. S. and Canada.....	53	The Importance of the Loud Speaker for Radio	127
Kilocycle-Meter Conversion Table	57	A Simple But Powerful Toroid Set	128
Calendar	59	How to Solder Properly	131
Time in All Parts of the World	59	Variable Resistance in Radio Circuits	135
Table for Making Time Transitions	59	How to Build the Silver Six	139
American Radio Relay League Directory	61	Analyzing the "Diamond of the Air"	143
Canadian Radio Broadcast Stations	63	Loud Speaker Uses Newly Discovered Principle	148
Blank Page for Logging Additional Stations	63	The Hammerland-Roberts Set	149
Foreign Radio Broadcast Stations (including U. S. Possessions)	67	Your Set May Be Down, But It's Never Out	152
How Uncle Sam is Clearing the Air	75	The Gen-Win Lemnis Coil Receiver	153
What the Beginner Should Know About Radio.....	77	A Plain Talk On Tone Quality	156
The How and Why of Radio Code	89	The Use of Resistance in Radio Sets	159
What to Expect of Your Radio Set	91	Correct Aerial Installation	161
Experiments with Transmitter Buttons	96	Power Tubes for Audio Amplification	162
How Many Radio Circuits Are There?	104	A Modern Method of Filament Control	163
How to Get the Most Out of Your Storage "A" Battery	108	The Elkay Tube Equalizer System	166
An Improved Super-Heterodyne	110	The Three Circuit Tuner	169
A Practical "B" Battery Eliminator	113	Index	176
		Changes in Radio Broadcast Stations	176
		S. Gernsback's Radio Encyclopedia	177

Additions to, Changes in, and Eliminations from list of United States Broadcast Stations.

New Stations

Call Signal	Location of Station	Owner	Power (Watts)	Wave Length	Frequency (Kilocycles)
KFIO	Spokane, Wash.	North Central High School	100	265.3	1,130
KFXR	Oklahoma, Okla.	Classen Film Finish Co.	15	214.2	1,400
KMMJ	Clay Center, Nebr.	M. M. Johnson Co.	500	228.9	1,310
WDAH	El Paso, Tex.	Trinity Methodist Church (South)	50	267.7	1,120
WQAC	Amarillo, Texas	Gish Radio Service	100	234.2	1,280

Changes

KFAU—(Boise, Idaho) W. L. 280.2, frequency 1,070 kilocycles.	WAAM—(Newark, N. J.)—Call signal changed to WBPI.
KFCF—(Walla Walla, Wash.)—Call signal changed to KOWW; power 500 watts; Owner of Station, Blue Mountain Radio Ass'n. (Frank A. Moore).	WAGM—(Royal Oak, Mich.)—Wave-length 225.4, frequency 1,330 kilocycles.
KFDJ—(Corvallis, Ore.)—Call signal changed to KOAC wave-length 280.2, frequency 1,070 kilocycles.	WBAL—(Baltimore, Md.)—Wave-length 245.8; frequency 1,220 kilocycles.
KFOB—(Burlingame, Cal.)—Owner of Station, KFOB (Inc.).	WDAF—(Cranston, R. I.)—Call signal changed to WDFW and WLSI; Owner of Station, Dutce W. Flint and Lincoln Studios (Inc.).
KFQB—(Fort Worth, Tex.)—Power 1,000 Watts.	WEAH—(Wichita, Kan.)—Call signal changed to KFH.
KGO—(Oakland, Cal.)—Power 4,000 Watts.	WEBK—(Grand Rapids, Mich.)—Call signal changed to WOOD.
KGTT—(San Francisco, Cal.)—Wave-length 206.8; frequency 1,450 kilocycles.	WMAQ—(Chicago, Ill.)—Power 1,000 Watts.
KYW—(Chicago, Ill.)—Power 3,500 Watts.	KNOX—(Knoxville, Tenn.)—Power 1,000 Watts.

Eliminations

KFBG—Tacoma, Wash.	KFRM—Fort Sill, Okla.	KFRY—State College, N. M.
KFVU—Eureka, Cal.	KFWP—Brownsville, Tex.	KFXE—Waterloo, Iowa.
WCAH—Columbus, O.	WCBG—Pascagoula, Miss.	WCUW—Worcester, Mass.
WEBT—Dayton, O.	WBGQ—Menomonee, Wis.	WHAG—Cincinnati, O.
WHBR—Cincinnati, O.	WJD—Granville, O.	WLAX—Greencastle, Ind.
WOAC—Limo, O.	WPDO—Buffalo, N. Y.	WTG—Manhattan, Kans.



There's a Real Thrill in trying a New Hook-Up!

EVERYONE in the family is eagerly waiting to hear the new set! After hours and hours of drilling and soldering, the set is nearly ready for its first crucial test. Will it meet with your expectations or will it be a disappointment? That depends upon two things—first your workmanship, and second, the quality of the parts used. Good workmanship is the result of patience, but good parts are assured only by demanding well-known, guaranteed products, such as Allen-Bradley Perfect Radio Devices. Allen-Bradley Products are known the world over for exceptional performance and fine appearance. They eliminate the hazard and disappointment that follows the use of inferior radio products.

Ask your dealer for Allen-Bradley Perfect Radio Devices if you value your time and labor. *They always work!*

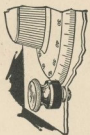

Bradleyner—Perfect Vernier Kaob.



Bradleyswitch—Perfect Battery Switch.



Bradleyleak—Perfect Grid Leak $\frac{1}{4}$ to 10 Megohms.



Bradleyometer—Perfect Potentiometer



Bradleystat—Perfect Filament Control for All Tubes.



Bradleyohm—Perfect Adjustable Resistor.



Bradleyunit—Perfect Fixed Resistor

Allen-Bradley Co.
Electric Controlling Apparatus

287
Greenfield
Ave.



Milwaukee,
Wisconsin

Mfrs. of Graphite Disc Rheostats for
Over 20 Years

ALLEN-BRADLEY CO.,
287 Greenfield Ave., Milwaukee, Wis.

Please send me your latest literature on the complete Allen-Bradley line of Perfect Radio Devices.

Name

Address

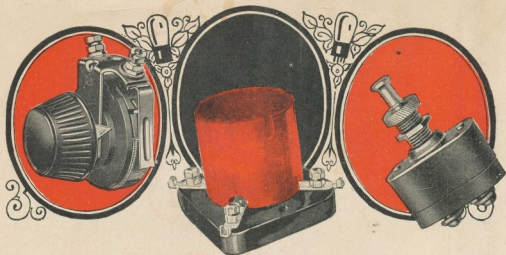

Give Your Tubes a Chance!

*For Real Efficiency Say "Cutler-Hammer"
When Buying These Vital Parts*

The very heart of any radio set is the vacuum tube. Its ability to function properly decides to a large extent the range of your set and the quality of your reception.

The Cutler-Hammer engineers have given lengthy study to the design of radio parts vital to tube efficiency. In the new Perfected C-H Rheostats are found features never before obtained. They give marvelously smooth, quiet control with an accuracy that is not disturbed during mounting of the instrument or after continued use. They make set building easy, anchoring absolutely rigid in a single hole in the panel. They add much to the quality of any set—and yet are lower in price.

Likewise, you can put the C-H Low Loss Socket [acclaimed by many engineers as the most perfect socket ever designed] in your set for maximum results, and actually save money in doing so. The same holds true for C-H Radio Switches—switches with real radio mechanisms that have so completely met the approval of the radio public that more than a million are in use today.

Before you build your new set, decide on quality parts. You will be interested in the folder "Radio Parts for Performance." Write for it—it's free.

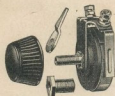

The Perfected C-H Rheostats are of the revolving drum type, designed with the operating parts as a unit. They are not dismantled for mounting, and hence all spring tensions, adjusted at the factory, are undisturbed. They are of unusually convenient small size, and are rated at 6, 15 and 30 ohms to handle all tubes and their combinations.



The revolutionary design of the C-H Low Loss Socket created a sensation everywhere. Thin ORANGE Bakelite shell. Base of heatproof Thermoplas—terminals cannot loosen under heat of soldering iron. One piece contact springs integral with soldering lugs. Contacts grip both sides of each tube prong and are SILVER plated to prevent corrosion losses. Preferred by careful builders at 90¢—now 60¢ because of huge production savings.

Say

THE CUTLER-HAMMER MFG. CO.
Member Radio Section, Associated Manufacturers of Electrical Supplies
Works: Milwaukee and New York



CUTLER-HAMMER

Buy Your Radio Parts by Name